

**DIPLOMADO DE PROFUNDIZACION CISCO
PRUEBA DE HABILIDADES PRÁCTICAS CCNP**

JHON JAIRO FERNANDEZ MORALES

**UNIVERSIDAD NACIONAL ABIERTA Y A DISTANCIA - UNAD ESCUELA DE
CIENCIAS BÁSICAS, TECNOLOGÍA E INGENIERÍA - ECBTI INGENIERÍA
ELECTRONICA CUCUTA**

2019

**DIPLOMADO DE PROFUNDIZACION CISCO
PRUEBA DE HABILIDADES PRÁCTICAS CCNP**

JHON JAIRO FERNANDEZ MORALES

Diplomado de opción de grado presentado para optar el título de INGENIERO
ELECTRONICO

DIRECTOR:

MSc. GERARDO GRANADOS ACUÑA

**UNIVERSIDAD NACIONAL ABIERTA Y A DISTANCIA - UNAD ESCUELA DE
CIENCIAS BÁSICAS, TECNOLOGÍA E INGENIERÍA - ECBTI INGENIERÍA
ELECTRONICA CUCUTA
2019**

NOTA DE ACEPTACIÓN

Firma del Presidente del Jurado

Firma del Jurado

Firma del Jurado

Cúcuta, 12 de diciembre de 2019

AGRADECIMIENTOS

En primera medida a Dios por todas las bendiciones, por la inteligencia y sabiduría para poder enfrentar cada uno de los retos del programa de ingeniería electrónica.

A mi madre por el amor, el apoyo constante, la paciencia, y por consentirme en cada una de las largas jornadas de estudio.

A mi novia por su cariño, el apoyo, la comprensión y sobre todo la paciencia.

A los profesores Liliana Esperanza Bautista Torres, Alexander Flórez Martínez, y Jenny Chacón por el apoyo intelectual ante cada una de las dificultades para con el desarrollo de las actividades del programa de ingeniería electrónica.

Por ultimo a mi familia en general por el apoyo brindado en cada una de las etapas de mi vida y por los momentos compartidos.

CONTENIDO

AGRADECIMIENTOS.....	4
LISTA DE TABLAS	6
LISTA DE FIGURAS	7
GLOSARIO	9
RESUMEN.....	11
ABSTRACT.....	11
INTRODUCCIÓN.....	13
DESARROLLO	14
Escenario 1.....	14
Escenario 2.....	40
CONCLUSIONES	68
BIBLIOGRAFÍA.....	69

LISTA DE TABLAS

Tabla 1. Equivalencia interfaces escenario 1.	15
Tabla 2. Lista VLANs DLS1.	46
Tabla 3. Lista interfaces para acceso a VLANs.	49

LISTA DE FIGURAS

Figura 1. Escenario 1.	14
Figura 2. Simulación de escenario 1.	15
Figura 3. Comando show ip route R1.	23
Figura 4. Comando show ipv6 route R1.	24
Figura 5. Comando show ip route R2.	24
Figura 6. Comando show ipv6 route R2.	25
Figura 7. Comando show ip route R3.	25
Figura 8. Comando show ipv6 route R3.	26
Figura 9. Comando ping desde R1 parte1.	27
Figura 10. Comando ping desde R1 parte 2.	28
Figura 11. Comando traceroute desde R1 parte 1.	29
Figura 12. Comando traceroute desde R1 parte 2.	30
Figura 13. Comando ping desde R2 parte 1.	31
Figura 14. Comando ping desde R2 parte 2.	32
Figura 15. Comando traceroute desde R2 parte 1.	33
Figura 16. Comando traceroute desde R2 parte 2.	34
Figura 17. Comando ping desde R3 parte 1.	35
Figura 18. Comando ping desde R3 parte 2.	36
Figura 19. Comando traceroute desde R3 parte 1.	37
Figura 20. Comando traceroute desde R3 parte 2.	38
Figura 21. Comando show ip protocols R2 EIRP 101 filtered by OSPF0	39
Figura 22. Escenario 2.	40
Figura 23. Simulación escenario 2.	41
Figura 24. Comando show interface trunk DLS1.	52
Figura 25. Comando show interface trunk DLS2.	53
Figura 26. Comando show interface trunk ALS1.	54
Figura 27. Comando show interface trunk ALS2.	55
Figura 28. Comando show etherchannel summary DLS1	56
Figura 29. Comando show etherchannel summary ALS1.	57
Figura 30. Comando show spanning-tree DLS1 parte 1.	58
Figura 31. Comando show spanning-tree DLS1 parte 2.	59
Figura 32. Comando show spanning-tree DLS1 parte 3.	60
Figura 33. Comando show spanning-tree DLS1 parte 4.	61
Figura 34. Comando show spanning-tree DLS1 parte 5.	62
Figura 35. Comando show spanning-tree DLS2 parte 1.	63
Figura 36. Comando show spanning-tree DLS2 parte 2.	64
Figura 37. Comando show spanning-tree DLS2 parte 3.	65

Figura 38. Comando show spanning-tree DLS2 parte 4.
Figura 39. Comando show spanning-tree DLS2 parte 5.

66
67

GLOSARIO

CCNP: Las siglas CCNP significan Cisco® Certified Network Professional, es una certificación otorgada por la empresa Cisco Systems. La Certificación CCNP Routing and Switching valida la capacidad para planificar, implementar, verificar y solucionar problemas de redes empresariales de área local y amplias y para trabajar colaborativamente con los especialistas en seguridad avanzada, voz, soluciones inalámbricas y de vídeo.

DCE: Equipo de comunicación de datos. Es un dispositivo que suministra los servicios de temporización a otro dispositivo.

DTP: es un protocolo propietario creado por Cisco Systems que opera entre switches Cisco, el cual automatiza la configuración de trunking (etiquetado de tramas de diferentes VLAN's con ISL o 802.1Q) en enlaces Ethernet.

EIGRP: es protocolo de enrutamiento del tipo vector distancia avanzado, utilizado en redes TCP/IP y de Interconexión de Sistemas Abierto (OSI), es propiedad de Cisco, y ofrece las mejores características de los algoritmos vector distancia y de estado de enlace.

Etherchannel: es una tecnología de Cisco construida de acuerdo con los estándares 802.3 full-duplex Fast Ethernet, que permite la agrupación lógica de varios enlaces físicos Ethernet, en donde esta agrupación es tratada como un único enlace y permite sumar la velocidad nominal de cada puerto físico Ethernet usado y así obtener un enlace troncal de alta velocidad.

GNS3: es un simulador gráfico de redes que permite diseñar topologías de red complejas y poner en marcha simulaciones sobre ellos permitiendo la combinación de dispositivos tanto reales como virtuales.

LACP: Protocolo de control de agregación de enlaces. Permite un cambio para negociar un paquete automático enviando paquetes LACP al igual. LACP busca consistencia de configuración y gestiona adiciones de enlaces y fallas entre dos switches.

OSPF: es un protocolo de red para enrutamiento jerárquico de pasarela interior o Interior Gateway Protocol (IGP), que usa el algoritmo Dijkstra, para calcular la ruta más corta entre dos nodos. Su medida de métrica se denomina cost, y tiene en cuenta diversos parámetros tales como el ancho de banda y la congestión de los enlaces.

OSPFV3: es el equivalente a OSPFv2 para intercambiar prefijos IPv6. Pero con la característica de familias de direcciones de OSPFv3, esta versión del protocolo es compatible con IPv4 e IPv6.

PAPG: Protocolo de Agregación de Puertos. Es un protocolo propiedad de Cisco, y funcionará solo en dispositivos Cisco. Los paquetes PAgP se intercambian entre conmutadores por puertos con capacidad EtherChannel. Los vecinos se identifican y las capacidades se aprenden y se comparan con las capacidades locales de conmutación.

TRUNKING: es una configuración de canal para puertos de switch que estén en una red Ethernet, que posibilita que se pueda pasar varias VLAN por un único enlace.

VLAN: (Red de área local virtual o LAN virtual) es una red de área local que agrupa un conjunto de equipos de manera lógica y no física.

VTP: es un protocolo de mensajes de nivel 2 usado para configurar y administrar VLANs en equipos Cisco. Permite centralizar y simplificar la administración en un dominio de VLANs, pudiendo crear, borrar y renombrar las mismas, reduciendo así la necesidad de configurar la misma VLAN en todos los nodos.

RESUMEN

En el presente trabajo se presenta el desarrollo de prueba de habilidades del diplomado de profundización CCNP, el cual está conformado por dos escenarios propuestos a los que se debe dar la solución como muestra de la adquisición de los conocimientos durante el desarrollo del mismo.

El primer escenario propone un ejercicio de redistribución entre EIGRP y OSPF con direccionamiento IP de doble pila IPv4 e IPv6, en donde se realiza la configuración de cada uno de los protocolos de enrutamiento en los respectivos dispositivos y posteriormente se realiza la redistribución tanto en EIGRP como en OSPF.

El segundo escenario propone un ejercicio de Switching en donde se configuran los puertos troncales y Port-channels, seguido del protocolo VTP para configuración y administración de las VLANs. Luego se configura el protocolo como Spanning tree root para asignación de raíces primarias y secundarias. Para terminar se configura el acceso a las VLANs y se verifica la conectividad de red de prueba y las opciones configuradas.

Palabras claves: CCNP, EIGRP, OSPF, VTP, VLAN, DTP, Trunking

ABSTRACT

This paper presents the development of skills test of the CCNP depth diploma, which is made up of two proposed scenarios to which the solution must be given as a sample of the acquisition of knowledge during its development.

The first scenario proposes a redistribution exercise between EIGRP and OSPF with IPv4 and IPv6 dual stack IP addressing, where the configuration of each of the routing protocols is performed on the device devices and subsequently redistribution is performed both in EIGRP and in OSPF.

The second scenario proposes a Switching exercise where the trunk and Port-channel ports are configured, followed by the VTP protocol for configuration and administration of the VLANs. The protocol is then configured as Spanning tree root for assigning primary and secondary roots. Finally, access the VLANs and verify the test network connectivity and the options configured.

Keywords: CCNP, EIGRP, OSPF, VTP, VLAN, DTP, Trunking.

INTRODUCCIÓN

El presente trabajo de grado tiene la presentación de la evaluación denominada “Prueba de habilidades prácticas”, que forma parte de las actividades evaluativas del Diplomado de Profundización CCNP tomado como opción de grado, y que busca identificar el grado de desarrollo de competencias y habilidades que fueron adquiridas a lo largo del diplomado. En donde lo esencial es poner a prueba los niveles de comprensión y solución de problemas relacionados con diversos aspectos de Networking, y de esta manera obtener el título de Ingeniero electrónico.

Los temas involucrados en el presente trabajo son: configuración EIGRP, configuración OSPF, redistribución entre EIGRP y OSPFv3, direccionamiento IP de doble pila IPv4 e IPv6, configuración VTP, configuración DTP, configuración VLAN y trunking, y uso de comandos de comprobación para Switching y Routing.

DESARROLLO

Escenario 1

Una empresa de confecciones posee tres sucursales distribuidas en las ciudades de Bogotá, Medellín y Bucaramanga, en donde el estudiante será el administrador de la red, el cual deberá configurar e interconectar entre sí cada uno de los dispositivos que forman parte del escenario, acorde con los lineamientos establecidos para el direccionamiento IP, protocolos de enrutamiento y demás aspectos que forman parte de la topología de red.

Topología de red

Figura 1. Escenario 1.



Figura 2. Simulación de escenario 1.



Equivalencia de las interfaces implementadas en el desarrollo de la práctica con las de la guía para mayor facilidad de interpretación:

Tabla 1. Equivalencia interfaces escenario 1.

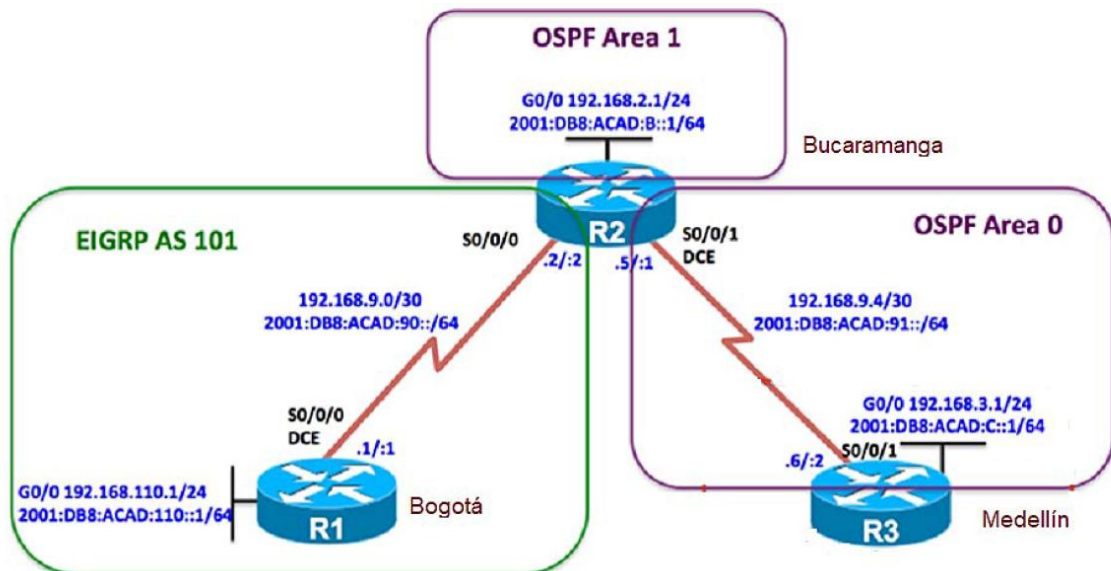
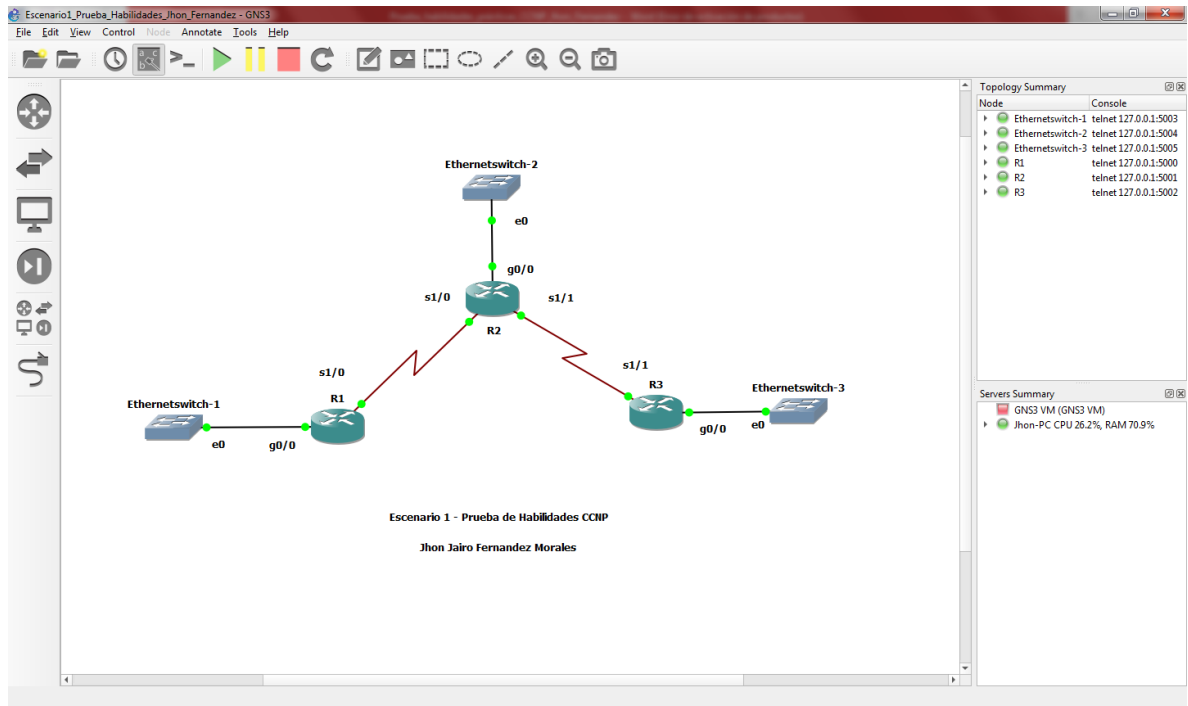
Router	Interfaz guía	Interfaz desarrollo
R1	S0/0/0	S1/0
R2	S0/0/0	S1/0
	S0/0/1	S1/1
R3	S0/0/1	S1/1

Configurar la topología de red, de acuerdo con las siguientes especificaciones.

Parte 1: Configuración del escenario propuesto

1. Configurar las interfaces con las direcciones IPv4 e IPv6 que se muestran en la topología de red.

R1#enable

R1#configure terminal

Enter configuration commands, one per line. End with CNTL/Z.

R1(config)#hostname R1

```
R1(config)#
R1(config)#no ip domain-lookup
R1(config)#line con 0
R1(config-line)#logging synchronous
R1(config-line)#exec-timeout 0 0
R1(config-line)#exit
R1(config)#
R1(config)#
R1(config)#interface GigabitEthernet 0/0
R1(config-if)#ip address 192.168.110.1 255.255.255.0
R1(config-if)#ipv6 address FE80::1 link-local
R1(config-if)#ipv6 address 2001:DB8:ACAD:110::1/64
R1(config-if)#no shutdown
R1(config-if)#exit
R1(config)#
R1(config)#interface Serial1/0
R1(config-if)#ip address 192.168.9.1 255.255.255.252
R1(config-if)#ipv6 address FE80::1 link-local
R1(config-if)#ipv6 address 2001:DB8:ACAD:90::1/64
R1(config-if)#no shutdown
R1(config-if)#exit
R1(config)#
```

```
R2#enable
R2#configure terminal
Enter configuration commands, one per line. End with CNTL/Z.
R2(config)#hostname R2
R2(config)#
R2(config)#no ip domain-lookup
R2(config)#line con 0
R2(config-line)#logging synchronous
R2(config-line)#exec-timeout 0 0
R2(config-line)#exit
R2(config)#
R2(config)#
R2(config)#interface GigabitEthernet 0/0
R2(config-if)#ip address 192.168.2.1 255.255.255.0
R2(config-if)#ipv6 address FE80::2 link-local
R2(config-if)#ipv6 address 2001:DB8:ACAD:B::1/64
R2(config-if)#no shutdown
R2(config-if)#exit
R2(config)#
R2(config)#interface Serial1/0
R2(config-if)#ip address 192.168.9.2 255.255.255.252
R2(config-if)#ipv6 address FE80::2 link-local
```

```
R2(config-if)#ipv6 address 2001:DB8:ACAD:90::2/64
R2(config-if)#no shutdown
R2(config-if)#exit
R2(config)#
R2(config)#interface Serial1/1
R2(config-if)#ip address 192.168.9.5 255.255.255.252
R2(config-if)#ipv6 address FE80::2 link-local
R2(config-if)#ipv6 address 2001:DB8:ACAD:91::1/64
R2(config-if)#no shutdown
R2(config-if)#exit
R2(config)#
```

```
R3#enable
R3#configure terminal
Enter configuration commands, one per line. End with CNTL/Z.
R3(config)#hostname R3
R3(config)#
R3(config)#no ip domain-lookup
R3(config)#line con 0
R3(config-line)#logging synchronous
R3(config-line)#exec-timeout 0 0
R3(config-line)#exit
R3(config)#
R3(config)#
R3(config)#interface GigabitEthernet 0/0
R3(config-if)#ip address 192.168.3.1 255.255.255.0
R3(config-if)#ipv6 address FE80::3 link-local
R3(config-if)#ipv6 address 2001:DB8:ACAD:C::1/64
R3(config-if)#no shutdown
R3(config-if)#exit
R3(config)#
R3(config)#interface Serial1/1
R3(config-if)#ip address 192.168.9.6 255.255.255.252
R3(config-if)#ipv6 address FE80::3 link-local
R3(config-if)#ipv6 address 2001:DB8:ACAD:91::2/64
R3(config-if)#no shutdown
R3(config-if)#exit
R3(config)#
```

2. Ajustar el ancho de banda a 128 kbps sobre cada uno de los enlaces seriales ubicados en R1, R2, y R3 y ajustar la velocidad de reloj de las conexiones de DCE según sea apropiado.

```
R1(config)#interface Serial1/0
R1(config-if)#clock rate 128000
```

```
R1(config-if)#bandwidth 128
R1(config-if)#exit
R1(config)#
```

```
R2(config)#interface Serial1/0
R2(config-if)#bandwidth 128
R2(config-if)#exit
R2(config)#
R2(config)#interface Serial1/1
R2(config-if)#clock rate 128000
R2(config-if)#bandwidth 128
R2(config-if)#exit
R2(config)#
```

```
R3(config)#interface Serial1/1
R3(config-if)#bandwidth 128
R3(config-if)#exit
R3(config)#
```

3. En R2 y R3 configurar las familias de direcciones OSPFv3 para IPv4 e IPv6. Utilice el identificador de enrutamiento 2.2.2.2 en R2 y 3.3.3.3 en R3 para ambas familias de direcciones.

```
R2(config)#ipv6 unicast-routing
R2(config)#router ospfv3 1
R2(config-router)#address-family ipv4 unicast
R2(config-router-af)#router-id 2.2.2.2
R2(config-router-af)#exit-address-family
R2(config-router)#
R2(config-router)#address-family ipv6 unicast
R2(config-router-af)#router-id 2.2.2.2
R2(config-router-af)#passive-interface gigabitethernet 0/0
R2(config-router-af)#exit-address-family
R2(config-router)#exit
R2(config)#
```

```
R3(config)#ipv6 unicast-routing
R3(config)#router ospfv3 1
R3(config-router)#address-family ipv4 unicast
R3(config-router-af)#router-id 3.3.3.3
R3(config-router-af)#passive-interface gigabitethernet 0/0
R3(config-router-af)#exit-address-family
R3(config-router)#
R3(config-router)#address-family ipv6 unicast
R3(config-router-af)#router-id 3.3.3.3
```

```
R3(config-router-af)#passive-interface gigabitethernet 0/0
R3(config-router-af)#exit-address-family
R3(config-router)#exit
R3(config)#
```

4. En R2, configurar la interfaz F0/0 en el área 1 de OSPF y la conexión serial entre R2 y R3 en OSPF área 0.

```
R2(config)#interface gigabitethernet 0/0
R2(config-if)#ospfv3 1 ipv4 area 1
R2(config-if)#ospfv3 1 ipv6 area 1
R2(config-if)#exit
R2(config)#
R2(config)#interface serial 1/1
R2(config-if)#ospfv3 1 ipv4 area 0
R2(config-if)#ospfv3 1 ipv6 area 0
R2(config-if)#exit
R2(config)#
```

5. En R3, configurar la interfaz F0/0 y la conexión serial entre R2 y R3 en OSPF área 0.

```
R3(config)#interface gigabitethernet 0/0
R3(config-if)#ospfv3 1 ipv4 area 0
R3(config-if)#ospfv3 1 ipv6 area 0
R3(config-if)#exit
R3(config)#
R3(config)#interface serial 1/1
R3(config-if)#ospfv3 1 ipv4 area 0
R3(config-if)#ospfv3 1 ipv6 area 0
R3(config-if)#exit
R3(config)#
```

6. Configurar el área 1 como un área totalmente Stubby.

```
R2(config)#router ospfv3 1
R2(config-router)#address-family ipv4 unicast
R2(config-router-af)#area 1 stub no-summary
R2(config-router-af)#exit-address-family
R2(config-router)#
R2(config-router)#address-family ipv6 unicast
R2(config-router-af)#area 1 stub no-summary
R2(config-router-af)#exit-address-family
R2(config-router)#exit
R2(config)#
```

7. Propagar rutas por defecto de IPv4 y IPv6 en R3 al interior del dominio OSPFv3.
Nota: Es importante tener en cuenta que una ruta por defecto es diferente a la definición de rutas estáticas.

```
R3(config)#ip route 0.0.0.0 0.0.0.0 192.168.9.5
R3(config)#ipv6 route ::/0 2001:DB8:ACAD:91::1
R3(config)#router ospfv3 1
R3(config-router)#address-family ipv4 unicast
R3(config-router-af)#default-information originate
R3(config-router-af)#exit-address-family
R3(config-router)#address-family ipv6 unicast
R3(config-router-af)#default-information originate
R3(config-router-af)#exit-address-family
R3(config-router)#exit
R3(config)#
```

8. Realizar la configuración del protocolo EIGRP para IPv4 como IPv6. Configurar la interfaz F0/0 de R1 y la conexión entre R1 y R2 para EIGRP con el sistema autónomo 101. Asegúrese de que el resumen automático está desactivado.

```
R1(config)#no router eigrp 101
%Attempting to deconfigure non-existent AS
R1(config)#no ipv6 router eigrp 101
R1(config)#
R1(config)#interface g0/0
R1(config-if)#no ipv6 eigrp 101
R1(config-if)#exit
R1(config)#interface s1/0
R1(config-if)#no ipv6 eigrp 101
R1(config-if)#exit
R1(config)#
R1(config)#ipv6 unicast-routing
R1(config)#router eigrp DUAL-STACK
R1(config-router)#address-family ipv4 unicast autonomous-system 101
R1(config-router-af)#eigrp router-id 1.1.1.1
R1(config-router-af)#network 192.168.110.0 0.0.0.255
R1(config-router-af)#network 192.168.9.0 0.0.0.3
R1(config-router-af)#topology base
R1(config-router-af-topology)#no auto-summary
R1(config-router-af-topology)#exit-af-topology
R1(config-router-af)#exit-address-family
R1(config-router)#
R1(config-router)#address-family ipv6 unicast autonomous-system 101
R1(config-router-af)#eigrp router-id 1.1.1.1
R1(config-router-af)#exit-address-family
R1(config-router)#exit
```

R1(config)#

```
R2(config)#no router eigrp 101
R2(config)#no ipv6 router eigrp 101
R2(config)#
R2(config)#interface s1/0
R2(config-if)#no ipv6 eigrp 101
R2(config-if)#exit
R2(config)#
R2(config)#ipv6 unicast-routing
R2(config)#router eigrp DUAL-STACK
R2(config-router)#address-family ipv4 unicast autonomous-system 101
R2(config-router-af)#eigrp router-id 22.22.22.22
R2(config-router-af)#network 192.168.9.0 0.0.0.3
R2(config-router-af)#topology base
R2(config-router-af-topology)#no auto-summary
R2(config-router-af-topology)#exit-af-topology
R2(config-router-af)#exit-address-family
R2(config-router)#
R2(config-router)#address-family ipv6 unicast autonomous-system 101
R2(config-router-af)#eigrp router-id 22.22.22.22
R2(config-router-af)#af-interface g0/0
R2(config-router-af-interface)#shutdown
R2(config-router-af-interface)#exit-af-interface
R2(config-router-af)#af-interface s1/1
R2(config-router-af-interface)#shutdown
R2(config-router-af-interface)#exit-af-interface
R2(config-router-af)#exit-address-family
R2(config-router)#exit
R2(config)#
```

9. Configurar las interfaces pasivas para EIGRP según sea apropiado.

```
R1(config)#router eigrp DUAL-STACK
R1(config-router)#address-family ipv4 unicast autonomous-system 101
R1(config-router-af)#af-interface gigabitethernet 0/0
R1(config-router-af-interface)#passive-interface
R1(config-router-af-interface)#exit-af-interface
R1(config-router-af)#exit-address-family
R1(config-router)#
R1(config-router)#address-family ipv6 unicast autonomous-system 101
R1(config-router-af)#af-interface gigabitethernet 0/0
R1(config-router-af-interface)#passive-interface
R1(config-router-af-interface)#exit-af-interface
R1(config-router-af)#exit-address-family
```

```
R1(config-router)#exit
R1(config)#
```

10. En R2, configurar la redistribución mutua entre OSPF y EIGRP para IPv4 e IPv6. Asignar métricas apropiadas cuando sea necesario.

```
R2(config)#router ospfv3 1
R2(config-router)#address-family ipv6 unicast
R2(config-router-af)#redistribute eigrp 101 include-connected
R2(config-router-af)#exit
R2(config-router)#exit
R2(config)#
R2(config)#
R2(config)#router eigrp DUAL-STACK
R2(config-router)#address-family ipv6 unicast autonomous-system 101
R2(config-router-af)#topology base
R2(config-router-af-topology)#redistribute ospf 1 metric 1500 100 255 1 1500
include-connected
R2(config-router-af-topology)#exit-af-topology
R2(config-router-af)#exit-address-family
R2(config-router)#exit
R2(config)#
R2(config)#
R2(config)#router ospfv3 1
R2(config-router)#address-family ipv4 unicast
R2(config-router-af)#redistribute eigrp 101
R2(config-router-af)#exit
R2(config-router)#exit
R2(config)#
R2(config)#router eigrp DUAL-STACK
R2(config-router)#address-family ipv4 unicast autonomous-system 101
R2(config-router-af)#topology base
R2(config-router-af-topology)#redistribute ospfv3 1 metric 1500 100 255 1 1500
R2(config-router-af-topology)#exit-af-topology
R2(config-router-af)#exit-address-family
R2(config-router)#exit
R2(config)#
```

11. En R2, de hacer publicidad de la ruta 192.168.3.0/24 a R1 mediante una lista de distribución y ACL.

```
R2(config)#ip access-list standard OSPF0
R2(config-std-nacl)#permit 192.168.3.0 0.0.0.255
R2(config-std-nacl)#permit any
R2(config-std-nacl)#exit
R2(config)#
```

```

R2(config)#
R2(config)#router eigrp DUAL-STACK
R2(config-router)#address-family ipv4 unicast autonomous-system 101
R2(config-router-af)#topology base
R2(config-router-af-topology)#distribute-list OSPF0 out ospf 1
R2(config-router-af-topology)#exit-af-topology
R2(config-router-af)#exit-address-family
R2(config-router)#exit
R2(config)#

```

Parte 2: Verificar conectividad de red y control de la trayectoria.

a. Registrar las tablas de enrutamiento en cada uno de los routers, acorde con los parámetros de configuración establecidos en el escenario propuesto.

R1

Figura 3. Comando show ip route R1.

```

R1#show ip route
Codes: L - local, C - connected, S - static, R - RIP, M - mobile, B - BGP
       D - EIGRP, EX - EIGRP external, O - OSPF, IA - OSPF inter area
       N1 - OSPF NSSA external type 1, N2 - OSPF NSSA external type 2
       E1 - OSPF external type 1, E2 - OSPF external type 2
       i - IS-IS, su - IS-IS summary, L1 - IS-IS level-1, L2 - IS-IS level-2
       ia - IS-IS inter area, * - candidate default, U - per-user static route
       o - ODR, P - periodic downloaded static route, H - NHRP, l - LISP
       a - application route
       + - replicated route, % - next hop override

Gateway of last resort is 192.168.9.2 to network 0.0.0.0

D*EX 0.0.0.0/0 [170/50752000] via 192.168.9.2, 00:05:55, Serial1/0
D EX  192.168.2.0/24 [170/50752000] via 192.168.9.2, 00:05:55, Serial1/0
D EX  192.168.3.0/24 [170/50752000] via 192.168.9.2, 00:05:55, Serial1/0
      192.168.9.0/24 is variably subnetted, 3 subnets, 2 masks
C      192.168.9.0/30 is directly connected, Serial1/0
L      192.168.9.1/32 is directly connected, Serial1/0
D EX  192.168.9.4/30 [170/50752000] via 192.168.9.2, 00:05:55, Serial1/0
      192.168.110.0/24 is variably subnetted, 2 subnets, 2 masks
C      192.168.110.0/24 is directly connected, GigabitEthernet0/0
L      192.168.110.1/32 is directly connected, GigabitEthernet0/0

```

Figura 4. Comando show ipv6 route R1.

```
R1#show ipv6 route
IPv6 Routing Table - default - 9 entries
Codes: C - Connected, L - Local, S - Static, U - Per-user Static route
        B - BGP, HA - Home Agent, MR - Mobile Router, R - RIP
        H - NHRP, I1 - ISIS L1, I2 - ISIS L2, IA - ISIS interarea
        IS - ISIS summary, D - EIGRP, EX - EIGRP external, NM - NEMO
        ND - ND Default, NDp - ND Prefix, DCE - Destination, NDR - Redirect
        O - OSPF Intra, OI - OSPF Inter, OE1 - OSPF ext 1, OE2 - OSPF ext 2
        ON1 - OSPF NSSA ext 1, ON2 - OSPF NSSA ext 2, la - LISP alt
        lr - LISP site-registrations, ld - LISP dyn-eid, a - Application
EX ::/0 [170/50752000]
    via FE80::2, Serial1/0
EX 2001:DB8:ACAD:B::/64 [170/50752000]
    via FE80::2, Serial1/0
EX 2001:DB8:ACAD:C::/64 [170/50752000]
    via FE80::2, Serial1/0
C 2001:DB8:ACAD:90::/64 [0/0]
    via Serial1/0, directly connected
L 2001:DB8:ACAD:90::1/128 [0/0]
    via Serial1/0, receive
EX 2001:DB8:ACAD:91::/64 [170/50752000]
    via FE80::2, Serial1/0
C 2001:DB8:ACAD:110::/64 [0/0]
    via GigabitEthernet0/0, directly connected
L 2001:DB8:ACAD:110::1/128 [0/0]
    via GigabitEthernet0/0, receive
L FF00::/8 [0/0]
    via Null0, receive
```

R2

Figura 5. Comando show ip route R2.

```
R2#show ip route
Codes: L - local, C - connected, S - static, R - RIP, M - mobile, B - BGP
        D - EIGRP, EX - EIGRP external, O - OSPF, IA - OSPF inter area
        N1 - OSPF NSSA external type 1, N2 - OSPF NSSA external type 2
        E1 - OSPF external type 1, E2 - OSPF external type 2
        i - IS-IS, su - IS-IS summary, L1 - IS-IS level-1, L2 - IS-IS level-2
        ia - IS-IS inter area, * - candidate default, U - per-user static route
        o - ODR, P - periodic downloaded static route, H - NHRP, l - LISP
        a - application route
        + - replicated route, % - next hop override

Gateway of last resort is 192.168.9.6 to network 0.0.0.0

O*E2 0.0.0.0/0 [110/1] via 192.168.9.6, 00:09:51, Serial1/1
    192.168.2.0/24 is variably subnetted, 2 subnets, 2 masks
C     192.168.2.0/24 is directly connected, GigabitEthernet0/0
L     192.168.2.1/32 is directly connected, GigabitEthernet0/0
O     192.168.3.0/24 [110/782] via 192.168.9.6, 00:09:51, Serial1/1
    192.168.9.0/24 is variably subnetted, 4 subnets, 2 masks
C     192.168.9.0/30 is directly connected, Serial1/0
L     192.168.9.2/32 is directly connected, Serial1/0
C     192.168.9.4/30 is directly connected, Serial1/1
L     192.168.9.5/32 is directly connected, Serial1/1
```

Figura 6. Comando show ipv6 route R2.

```
R2#show ipv6 route
IPv6 Routing Table - default - 10 entries
Codes: C - Connected, L - Local, S - Static, U - Per-user Static route
        B - BGP, HA - Home Agent, MR - Mobile Router, R - RIP
        H - NHRP, I1 - ISIS L1, I2 - ISIS L2, IA - ISIS interarea
        IS - ISIS summary, D - EIGRP, EX - EIGRP external, NM - NEMO
        ND - ND Default, NDp - ND Prefix, DCE - Destination, NDR - Redirect
        O - OSPF Intra, OI - OSPF Inter, OE1 - OSPF ext 1, OE2 - OSPF ext 2
        ON1 - OSPF NSSA ext 1, ON2 - OSPF NSSA ext 2, la - LISP alt
        lr - LISP site-registrations, ld - LISP dyn-eid, a - Application
OE2 ::0 [110/1], tag 1
    via FE80::3, Serial1/1
C   2001:DB8:ACAD:B::/64 [0/0]
    via GigabitEthernet0/0, directly connected
L   2001:DB8:ACAD:B::1/128 [0/0]
    via GigabitEthernet0/0, receive
O   2001:DB8:ACAD:C::/64 [110/782]
    via FE80::3, Serial1/1
C   2001:DB8:ACAD:90::/64 [0/0]
    via Serial1/0, directly connected
L   2001:DB8:ACAD:90::2/128 [0/0]
    via Serial1/0, receive
C   2001:DB8:ACAD:91::/64 [0/0]
    via Serial1/1, directly connected
L   2001:DB8:ACAD:91::1/128 [0/0]
    via Serial1/1, receive
D   2001:DB8:ACAD:110::/64 [90/50245120]
    via FE80::1, Serial1/0
L   FF00::/8 [0/0]
    via Null0, receive
```

R3

Figura 7. Comando show ip route R3.

```
R3#show ip route
Codes: L - local, C - connected, S - static, R - RIP, M - mobile, B - BGP
        D - EIGRP, EX - EIGRP external, O - OSPF, IA - OSPF inter area
        N1 - OSPF NSSA external type 1, N2 - OSPF NSSA external type 2
        E1 - OSPF external type 1, E2 - OSPF external type 2
        i - IS-IS, su - IS-IS summary, L1 - IS-IS level-1, L2 - IS-IS level-2
        ia - IS-IS inter area, * - candidate default, U - per-user static route
        o - ODR, P - periodic downloaded static route, H - NHRP, l - LISP
        a - application route
        + - replicated route, % - next hop override

Gateway of last resort is 192.168.9.5 to network 0.0.0.0

S*   0.0.0.0/0 [1/0] via 192.168.9.5
O IA  192.168.2.0/24 [110/782] via 192.168.9.5, 00:13:53, Serial1/1
      192.168.3.0/24 is variably subnetted, 2 subnets, 2 masks
C     192.168.3.0/24 is directly connected, GigabitEthernet0/0
L     192.168.3.1/32 is directly connected, GigabitEthernet0/0
      192.168.9.0/24 is variably subnetted, 3 subnets, 2 masks
O E2  192.168.9.0/30 [110/20] via 192.168.9.5, 00:13:48, Serial1/1
C     192.168.9.4/30 is directly connected, Serial1/1
L     192.168.9.6/32 is directly connected, Serial1/1
O E2  192.168.110.0/24 [110/20] via 192.168.9.5, 00:13:48, Serial1/1
```

Figura 8. Comando show ipv6 route R3.

```
R3#show ipv6 route
IPv6 Routing Table - default - 9 entries
Codes: C - Connected, L - Local, S - Static, U - Per-user Static route
       B - BGP, HA - Home Agent, MR - Mobile Router, R - RIP
       H - NHRP, I1 - ISIS L1, I2 - ISIS L2, IA - ISIS interarea
       IS - ISIS summary, D - EIGRP, EX - EIGRP external, NM - NEMO
       ND - ND Default, NDp - ND Prefix, DCE - Destination, NDr - Redirect
       O - OSPF Intra, OI - OSPF Inter, OE1 - OSPF ext 1, OE2 - OSPF ext 2
       ON1 - OSPF NSSA ext 1, ON2 - OSPF NSSA ext 2, la - LISP alt
       lr - LISP site-registrations, ld - LISP dyn-eid, a - Application
S  ::/0 [1/0]
   via 2001:DB8:ACAD:91::1
OI 2001:DB8:ACAD:B::/64 [110/782]
   via FE80::2, Serial1/1
C  2001:DB8:ACAD:C::/64 [0/0]
   via GigabitEthernet0/0, directly connected
L  2001:DB8:ACAD:C::1/128 [0/0]
   via GigabitEthernet0/0, receive
OE2 2001:DB8:ACAD:90::/64 [110/20]
   via FE80::2, Serial1/1
C  2001:DB8:ACAD:91::/64 [0/0]
   via Serial1/1, directly connected
L  2001:DB8:ACAD:91::2/128 [0/0]
   via Serial1/1, receive
OE2 2001:DB8:ACAD:110::/64 [110/20]
   via FE80::2, Serial1/1
L  FF00::/8 [0/0]
   via Null0, receive
```

- b. Verificar comunicación entre routers mediante el comando ping y traceroute.
R1.

Figura 9. Comando ping desde R1 parte1.

```
R1#
R1#tclsh
R1(tcl)#
R1(tcl)#foreach address {
+>(tcl)#192.168.110.1
+>(tcl)#192.168.9.1
+>(tcl)#192.168.9.2
+>(tcl)#192.168.2.1
+>(tcl)#192.168.9.5
+>(tcl)#192.168.9.6
+>(tcl)#192.168.3.1
+>(tcl)#2001:db8:acad:110::1
+>(tcl)#2001:db8:acad:90::1
+>(tcl)#2001:db8:acad:90::2
+>(tcl)#2001:db8:acad:b::1
+>(tcl)#2001:db8:acad:91::1
+>(tcl)#2001:db8:acad:91::2
+>(tcl)#2001:db8:acad:c::1
+>(tcl)#} { ping $address }
Type escape sequence to abort.
Sending 5, 100-byte ICMP Echos to 192.168.110.1, timeout is 2 seconds:
!!!!!!
Success rate is 100 percent (5/5), round-trip min/avg/max = 4/5/8 ms
Type escape sequence to abort.
Sending 5, 100-byte ICMP Echos to 192.168.9.1, timeout is 2 seconds:
!!!!!!
Success rate is 100 percent (5/5), round-trip min/avg/max = 20/32/44 ms
Type escape sequence to abort.
Sending 5, 100-byte ICMP Echos to 192.168.9.2, timeout is 2 seconds:
!!!!!!
Success rate is 100 percent (5/5), round-trip min/avg/max = 8/12/24 ms
Type escape sequence to abort.
Sending 5, 100-byte ICMP Echos to 192.168.2.1, timeout is 2 seconds:
!!!!!!
Success rate is 100 percent (5/5), round-trip min/avg/max = 8/16/24 ms
Type escape sequence to abort.
Sending 5, 100-byte ICMP Echos to 192.168.9.5, timeout is 2 seconds:
!!!!!!
Success rate is 100 percent (5/5), round-trip min/avg/max = 8/9/12 ms
Type escape sequence to abort.
Sending 5, 100-byte ICMP Echos to 192.168.9.6, timeout is 2 seconds:
!!!!!!
Success rate is 100 percent (5/5), round-trip min/avg/max = 16/21/32 ms
Type escape sequence to abort.
Sending 5, 100-byte ICMP Echos to 192.168.3.1, timeout is 2 seconds:
!!!!!!
Success rate is 100 percent (5/5), round-trip min/avg/max = 16/20/24 ms
```

Figura 10. Comando ping desde R1 parte 2.

```
Type escape sequence to abort.
Sending 5, 100-byte ICMP Echos to 2001:DB8:ACAD:110::1, timeout is 2 seconds:
!!!!
Success rate is 100 percent (5/5), round-trip min/avg/max = 1/2/4 ms
Type escape sequence to abort.
Sending 5, 100-byte ICMP Echos to 2001:DB8:ACAD:90::1, timeout is 2 seconds:
!!!!
Success rate is 100 percent (5/5), round-trip min/avg/max = 1/1/4 ms
Type escape sequence to abort.
Sending 5, 100-byte ICMP Echos to 2001:DB8:ACAD:90::2, timeout is 2 seconds:
!!!!
Success rate is 100 percent (5/5), round-trip min/avg/max = 1/14/24 ms
Type escape sequence to abort.
Sending 5, 100-byte ICMP Echos to 2001:DB8:ACAD:8::1, timeout is 2 seconds:
!!!!
Success rate is 100 percent (5/5), round-trip min/avg/max = 8/8/12 ms
Type escape sequence to abort.
Sending 5, 100-byte ICMP Echos to 2001:DB8:ACAD:91::1, timeout is 2 seconds:
!!!!
Success rate is 100 percent (5/5), round-trip min/avg/max = 4/7/12 ms
Type escape sequence to abort.
Sending 5, 100-byte ICMP Echos to 2001:DB8:ACAD:91::2, timeout is 2 seconds:
!!!!
Success rate is 100 percent (5/5), round-trip min/avg/max = 8/16/32 ms
Type escape sequence to abort.
Sending 5, 100-byte ICMP Echos to 2001:DB8:ACAD:C::1, timeout is 2 seconds:
!!!!
Success rate is 100 percent (5/5), round-trip min/avg/max = 12/16/24 ms
R1(tc1)#
```

Figura 11. Comando traceroute desde R1 parte 1.

```
R1(tcl)#foreach address {
+>(tcl)#192.168.110.1
+>(tcl)#192.168.9.1
+>(tcl)#192.168.9.2
+>(tcl)#192.168.2.1
+>(tcl)#192.168.9.5
+>(tcl)#192.168.9.6
+>(tcl)#192.168.3.1
+>(tcl)#2001:db8:acad:110::1
+>(tcl)#2001:db8:acad:90::1
+>(tcl)#2001:db8:acad:90::2
+>(tcl)#2001:db8:acad:b::1
+>(tcl)#2001:db8:acad:91::1
+>(tcl)#2001:db8:acad:91::2
+>(tcl)#2001:db8:acad:c::1
+>(tcl)#} { traceroute $address }
Type escape sequence to abort.
Tracing the route to 192.168.110.1
VRF info: (vrf in name/id, vrf out name/id)
 1 192.168.110.1 8 msec 4 msec 8 msec
Type escape sequence to abort.
Tracing the route to 192.168.9.1
VRF info: (vrf in name/id, vrf out name/id)
 1 192.168.9.2 12 msec 20 msec 8 msec
 2 192.168.9.1 20 msec 16 msec 16 msec
Type escape sequence to abort.
Tracing the route to 192.168.9.2
VRF info: (vrf in name/id, vrf out name/id)
 1 192.168.9.2 12 msec 24 msec 20 msec
Type escape sequence to abort.
Tracing the route to 192.168.2.1
VRF info: (vrf in name/id, vrf out name/id)
 1 192.168.9.2 12 msec 12 msec 16 msec
Type escape sequence to abort.
Tracing the route to 192.168.9.5
VRF info: (vrf in name/id, vrf out name/id)
 1 192.168.9.2 12 msec 12 msec 16 msec
Type escape sequence to abort.
Tracing the route to 192.168.9.6
VRF info: (vrf in name/id, vrf out name/id)
 1 192.168.9.2 16 msec 8 msec 8 msec
 2 192.168.9.6 12 msec 28 msec 44 msec
Type escape sequence to abort.
Tracing the route to 192.168.3.1
VRF info: (vrf in name/id, vrf out name/id)
 1 192.168.9.2 12 msec 16 msec 16 msec
 2 192.168.9.6 16 msec 28 msec 36 msec
```

Figura 12. Comando traceroute desde R1 parte 2.

```
Type escape sequence to abort.
Tracing the route to 2001:DB8:ACAD:110::1

 1 2001:DB8:ACAD:110::1 0 msec 0 msec 0 msec
Type escape sequence to abort.
Tracing the route to 2001:DB8:ACAD:90::1

 1 2001:DB8:ACAD:90::1 0 msec 0 msec 4 msec
Type escape sequence to abort.
Tracing the route to 2001:DB8:ACAD:90::2

 1 2001:DB8:ACAD:90::2 8 msec 12 msec 4 msec
Type escape sequence to abort.
Tracing the route to 2001:DB8:ACAD:B::1

 1 2001:DB8:ACAD:90::2 20 msec 12 msec 8 msec% Unrecognized host or address.
Type escape sequence to abort.
Tracing the route to 2001:DB8:ACAD:91::2

 1 2001:DB8:ACAD:90::2 4 msec 16 msec 8 msec
 2 2001:DB8:ACAD:91::2 12 msec 20 msec 20 msec
Type escape sequence to abort.
Tracing the route to 2001:DB8:ACAD:C::1

 1 2001:DB8:ACAD:90::2 12 msec 12 msec 8 msec
 2 2001:DB8:ACAD:91::2 8 msec 16 msec 16 msec
R1(tcl)#
```

R2

Figura 13. Comando ping desde R2 parte 1.

```
R2#tclsh
R2(tcl)#
R2(tcl)#foreach address {
+>(tcl)#192.168.110.1
+>(tcl)#192.168.9.1
+>(tcl)#192.168.9.2
+>(tcl)#192.168.2.1
+>(tcl)#192.168.9.5
+>(tcl)#192.168.9.6
+>(tcl)#192.168.3.1
+>(tcl)#2001:db8:acad:110::1
+>(tcl)#2001:db8:acad:90::1
+>(tcl)#2001:db8:acad:90::2
+>(tcl)#2001:db8:acad:b::1
+>(tcl)#2001:db8:acad:91::1
+>(tcl)#2001:db8:acad:91::2
+>(tcl)#2001:db8:acad:c::1
+>(tcl)#} { ping $address }
Type escape sequence to abort.
Sending 5, 100-byte ICMP Echos to 192.168.110.1, timeout is 2 seconds:
!!!!
Success rate is 100 percent (5/5), round-trip min/avg/max = 8/12/24 ms
Type escape sequence to abort.
Sending 5, 100-byte ICMP Echos to 192.168.9.1, timeout is 2 seconds:
!!!!
Success rate is 100 percent (5/5), round-trip min/avg/max = 4/12/20 ms
Type escape sequence to abort.
Sending 5, 100-byte ICMP Echos to 192.168.9.2, timeout is 2 seconds:
!!!!
Success rate is 100 percent (5/5), round-trip min/avg/max = 24/27/36 ms
Type escape sequence to abort.
Sending 5, 100-byte ICMP Echos to 192.168.2.1, timeout is 2 seconds:
!!!!
Success rate is 100 percent (5/5), round-trip min/avg/max = 1/2/4 ms
Type escape sequence to abort.
Sending 5, 100-byte ICMP Echos to 192.168.9.5, timeout is 2 seconds:
!!!!
Success rate is 100 percent (5/5), round-trip min/avg/max = 20/23/32 ms
Type escape sequence to abort.
Sending 5, 100-byte ICMP Echos to 192.168.9.6, timeout is 2 seconds:
!!!!
Success rate is 100 percent (5/5), round-trip min/avg/max = 4/12/20 ms
Type escape sequence to abort.
Sending 5, 100-byte ICMP Echos to 192.168.3.1, timeout is 2 seconds:
!!!!
Success rate is 100 percent (5/5), round-trip min/avg/max = 4/7/8 ms
```

Figura 14. Comando ping desde R2 parte 2.

```
Type escape sequence to abort.
Sending 5, 100-byte ICMP Echos to 2001:DB8:ACAD:110::1, timeout is 2 seconds:
!!!!
Success rate is 100 percent (5/5), round-trip min/avg/max = 8/9/12 ms
Type escape sequence to abort.
Sending 5, 100-byte ICMP Echos to 2001:DB8:ACAD:90::1, timeout is 2 seconds:
!!!!
Success rate is 100 percent (5/5), round-trip min/avg/max = 1/7/12 ms
Type escape sequence to abort.
Sending 5, 100-byte ICMP Echos to 2001:DB8:ACAD:90::2, timeout is 2 seconds:
!!!!
Success rate is 100 percent (5/5), round-trip min/avg/max = 1/2/4 ms
Type escape sequence to abort.
Sending 5, 100-byte ICMP Echos to 2001:DB8:ACAD:8::1, timeout is 2 seconds:
!!!!
Success rate is 100 percent (5/5), round-trip min/avg/max = 1/1/4 ms
Type escape sequence to abort.
Sending 5, 100-byte ICMP Echos to 2001:DB8:ACAD:91::1, timeout is 2 seconds:
!!!!
Success rate is 100 percent (5/5), round-trip min/avg/max = 1/1/4 ms
Type escape sequence to abort.
Sending 5, 100-byte ICMP Echos to 2001:DB8:ACAD:91::2, timeout is 2 seconds:
!!!!
Success rate is 100 percent (5/5), round-trip min/avg/max = 4/8/12 ms
Type escape sequence to abort.
Sending 5, 100-byte ICMP Echos to 2001:DB8:ACAD:C::1, timeout is 2 seconds:
!!!!
Success rate is 100 percent (5/5), round-trip min/avg/max = 4/11/20 ms
R2(tcl)#
```

Figura 15. Comando traceroute desde R2 parte 1.

```
R2(tcl)#foreach address {
+>(tcl)#192.168.110.1
+>(tcl)#192.168.9.1
+>(tcl)#192.168.9.2
+>(tcl)#192.168.2.1
+>(tcl)#192.168.9.5
+>(tcl)#192.168.9.6
+>(tcl)#192.168.3.1
+>(tcl)#2001:db8:acad:110::1
+>(tcl)#2001:db8:acad:90::1
+>(tcl)#2001:db8:acad:90::2
+>(tcl)#2001:db8:acad:b::1
+>(tcl)#2001:db8:acad:91::1
+>(tcl)#2001:db8:acad:91::2
+>(tcl)#2001:db8:acad:c::1
+>(tcl)#} { traceroute $address }
Type escape sequence to abort.
Tracing the route to 192.168.110.1
VRF info: (vrf in name/id, vrf out name/id)
  1 192.168.9.1 24 msec 28 msec 16 msec
Type escape sequence to abort.
Tracing the route to 192.168.9.1
VRF info: (vrf in name/id, vrf out name/id)
  1 192.168.9.1 8 msec 8 msec 8 msec
Type escape sequence to abort.
Tracing the route to 192.168.9.2
VRF info: (vrf in name/id, vrf out name/id)
  1 192.168.9.1 12 msec 4 msec 16 msec
  2 192.168.9.2 32 msec 20 msec 32 msec
Type escape sequence to abort.
Tracing the route to 192.168.2.1
VRF info: (vrf in name/id, vrf out name/id)
  1 192.168.2.1 4 msec 4 msec 4 msec
Type escape sequence to abort.
Tracing the route to 192.168.9.5
VRF info: (vrf in name/id, vrf out name/id)
  1 192.168.9.6 12 msec 8 msec 16 msec
  2 192.168.9.5 16 msec 24 msec 24 msec
Type escape sequence to abort.
Tracing the route to 192.168.9.6
VRF info: (vrf in name/id, vrf out name/id)
  1 192.168.9.6 16 msec 12 msec 4 msec
Type escape sequence to abort.
Tracing the route to 192.168.3.1
VRF info: (vrf in name/id, vrf out name/id)
  1 192.168.9.6 8 msec 8 msec 20 msec
```

Figura 16. Comando traceroute desde R2 parte 2.

```
Type escape sequence to abort.
Tracing the route to 2001:DB8:ACAD:110::1

 1 2001:DB8:ACAD:90::1 12 msec 16 msec 16 msec
Type escape sequence to abort.
Tracing the route to 2001:DB8:ACAD:90::1

 1 2001:DB8:ACAD:90::1 8 msec 16 msec 16 msec
Type escape sequence to abort.
Tracing the route to 2001:DB8:ACAD:90::2

 1 2001:DB8:ACAD:90::2 0 msec 4 msec 0 msec
Type escape sequence to abort.
Tracing the route to 2001:DB8:ACAD:B::1

 1 2001:DB8:ACAD:B::1 0 msec 0 msec 0 msec% Unrecognized host or address.
Type escape sequence to abort.
Tracing the route to 2001:DB8:ACAD:91::2

 1 2001:DB8:ACAD:91::2 8 msec 16 msec 16 msec
Type escape sequence to abort.
Tracing the route to 2001:DB8:ACAD:C::1

 1 2001:DB8:ACAD:91::2 4 msec 20 msec 12 msec
R2(tcl)#
```

R3

Figura 17. Comando ping desde R3 parte 1.

```
R3(tcl)#foreach address {
+>(tcl)#192.168.110.1
+>(tcl)#192.168.9.1
+>(tcl)#192.168.9.2
+>(tcl)#192.168.2.1
+>(tcl)#192.168.9.5
+>(tcl)#192.168.9.6
+>(tcl)#192.168.3.1
+>(tcl)#2001:db8:acad:110::1
+>(tcl)#2001:db8:acad:90::1
+>(tcl)#2001:db8:acad:90::2
+>(tcl)#2001:db8:acad:b::1
+>(tcl)#2001:db8:acad:91::1
+>(tcl)#2001:db8:acad:91::2
+>(tcl)#2001:db8:acad:c::1
+>(tcl)#} { ping $address }
Type escape sequence to abort.
Sending 5, 100-byte ICMP Echos to 192.168.110.1, timeout is 2 seconds:
!!!!
Success rate is 100 percent (5/5), round-trip min/avg/max = 16/27/40 ms
Type escape sequence to abort.
Sending 5, 100-byte ICMP Echos to 192.168.9.1, timeout is 2 seconds:
!!!!
Success rate is 100 percent (5/5), round-trip min/avg/max = 12/24/48 ms
Type escape sequence to abort.
Sending 5, 100-byte ICMP Echos to 192.168.9.2, timeout is 2 seconds:
!!!!
Success rate is 100 percent (5/5), round-trip min/avg/max = 12/20/36 ms
Type escape sequence to abort.
Sending 5, 100-byte ICMP Echos to 192.168.2.1, timeout is 2 seconds:
!!!!
Success rate is 100 percent (5/5), round-trip min/avg/max = 4/6/8 ms
Type escape sequence to abort.
Sending 5, 100-byte ICMP Echos to 192.168.9.5, timeout is 2 seconds:
!!!!
Success rate is 100 percent (5/5), round-trip min/avg/max = 8/10/12 ms
Type escape sequence to abort.
Sending 5, 100-byte ICMP Echos to 192.168.9.6, timeout is 2 seconds:
!!!!
Success rate is 100 percent (5/5), round-trip min/avg/max = 16/20/28 ms
Type escape sequence to abort.
Sending 5, 100-byte ICMP Echos to 192.168.3.1, timeout is 2 seconds:
!!!!
Success rate is 100 percent (5/5), round-trip min/avg/max = 1/2/4 ms
```

Figura 18. Comando ping desde R3 parte 2.

```
Type escape sequence to abort.
Sending 5, 100-byte ICMP Echos to 2001:DB8:ACAD:110::1, timeout is 2 seconds:
!!!!
Success rate is 100 percent (5/5), round-trip min/avg/max = 16/27/36 ms
Type escape sequence to abort.
Sending 5, 100-byte ICMP Echos to 2001:DB8:ACAD:90::1, timeout is 2 seconds:
!!!!
Success rate is 100 percent (5/5), round-trip min/avg/max = 8/20/32 ms
Type escape sequence to abort.
Sending 5, 100-byte ICMP Echos to 2001:DB8:ACAD:90::2, timeout is 2 seconds:
!!!!
Success rate is 100 percent (5/5), round-trip min/avg/max = 4/15/24 ms
Type escape sequence to abort.
Sending 5, 100-byte ICMP Echos to 2001:DB8:ACAD:B::1, timeout is 2 seconds:
!!!!
Success rate is 100 percent (5/5), round-trip min/avg/max = 8/16/28 ms
Type escape sequence to abort.
Sending 5, 100-byte ICMP Echos to 2001:DB8:ACAD:91::1, timeout is 2 seconds:
!!!!
Success rate is 100 percent (5/5), round-trip min/avg/max = 8/14/20 ms
Type escape sequence to abort.
Sending 5, 100-byte ICMP Echos to 2001:DB8:ACAD:91::2, timeout is 2 seconds:
!!!!
Success rate is 100 percent (5/5), round-trip min/avg/max = 1/1/4 ms
Type escape sequence to abort.
Sending 5, 100-byte ICMP Echos to 2001:DB8:ACAD:C::1, timeout is 2 seconds:
!!!!
Success rate is 100 percent (5/5), round-trip min/avg/max = 1/2/4 ms
R3(tcl)#
```

Figura 19. Comando traceroute desde R3 parte 1.

```
R3(tcl)#foreach address {
+>(tcl)#192.168.110.1
+>(tcl)#192.168.9.1
+>(tcl)#192.168.9.2
+>(tcl)#192.168.2.1
+>(tcl)#192.168.9.5
+>(tcl)#192.168.9.6
+>(tcl)#192.168.3.1
+>(tcl)#2001:db8:acad:110::1
+>(tcl)#2001:db8:acad:90::1
+>(tcl)#2001:db8:acad:90::2
+>(tcl)#2001:db8:acad:b::1
+>(tcl)#2001:db8:acad::91::1
+>(tcl)#2001:db8:acad:91::2
+>(tcl)#2001:db8:acad:c::1
+>(tcl)#} { traceroute $address }
Type escape sequence to abort.
Tracing the route to 192.168.110.1
VRF info: (vrf in name/id, vrf out name/id)
  1 192.168.9.5 28 msec 36 msec 16 msec
  2 192.168.9.1 16 msec 24 msec 32 msec
Type escape sequence to abort.
Tracing the route to 192.168.9.1
VRF info: (vrf in name/id, vrf out name/id)
  1 192.168.9.5 8 msec 12 msec 8 msec
  2 192.168.9.1 8 msec 12 msec 20 msec
Type escape sequence to abort.
Tracing the route to 192.168.9.2
VRF info: (vrf in name/id, vrf out name/id)
  1 192.168.9.5 0 msec 20 msec 12 msec
Type escape sequence to abort.
Tracing the route to 192.168.2.1
VRF info: (vrf in name/id, vrf out name/id)
  1 192.168.9.5 12 msec 12 msec 8 msec
Type escape sequence to abort.
Tracing the route to 192.168.9.5
VRF info: (vrf in name/id, vrf out name/id)
  1 192.168.9.5 16 msec 16 msec 20 msec
Type escape sequence to abort.
Tracing the route to 192.168.9.6
VRF info: (vrf in name/id, vrf out name/id)
  1 192.168.9.5 12 msec 8 msec 16 msec
  2 192.168.9.6 24 msec 16 msec 20 msec
Type escape sequence to abort.
Tracing the route to 192.168.3.1
VRF info: (vrf in name/id, vrf out name/id)
  1 192.168.3.1 8 msec 4 msec 4 msec
```

Figura 20. Comando traceroute desde R3 parte 2.

```
Type escape sequence to abort.
Tracing the route to 2001:DB8:ACAD:110::1

 1 2001:DB8:ACAD:91::1 20 msec 12 msec 8 msec
 2 2001:DB8:ACAD:90::1 8 msec 32 msec 12 msec
Type escape sequence to abort.
Tracing the route to 2001:DB8:ACAD:90::1

 1 2001:DB8:ACAD:91::1 8 msec 8 msec 8 msec
 2 2001:DB8:ACAD:90::1 8 msec 28 msec 28 msec
Type escape sequence to abort.
Tracing the route to 2001:DB8:ACAD:90::2

 1 2001:DB8:ACAD:91::1 12 msec 8 msec 16 msec
Type escape sequence to abort.
Tracing the route to 2001:DB8:ACAD:B::1

 1 2001:DB8:ACAD:91::1 8 msec 20 msec 0 msec% Unrecognized host or address.
Type escape sequence to abort.
Tracing the route to 2001:DB8:ACAD:91::2

 1 2001:DB8:ACAD:91::2 0 msec 0 msec 4 msec
Type escape sequence to abort.
Tracing the route to 2001:DB8:ACAD:C::1

 1 2001:DB8:ACAD:C::1 0 msec 4 msec 0 msec
R3(tcl)#
```

c. Verificar que las rutas filtradas no están presentes en las tablas de enrutamiento de los routers correctas.

Nota: Puede ser que Una o más direcciones no serán accesibles desde todos los routers después de la configuración final debido a la utilización de listas de distribución para filtrar rutas y el uso de IPv4 e IPv6 en la misma red.

R1

Figura 21. Comando show ip protocols R2 EIRP 101 filtered by OSPF0

```
Routing Protocol is "eigrp 101"
  Outgoing update filter list for all interfaces is not set
  Redistributed ospf 1 filtered by OSPF0
  Incoming update filter list for all interfaces is not set
  Default networks flagged in outgoing updates
  Default networks accepted from incoming updates
  Redistributing: ospfv3 1
  EIGRP-IPv4 VR(DUAL-STACK) Address-Family Protocol for AS(101)
  Metric weight K1=1, K2=0, K3=1, K4=0, K5=0 K6=0
  Metric rib-scale 128
  Metric version 64bit
  NSF-aware route hold timer is 240
  Router-ID: 22.22.22.22
  Topology : 0 (base)
  Active Timer: 3 min
  Distance: internal 90 external 170
  Maximum path: 4
  Maximum hopcount 100
  Maximum metric variance 1
  Total Prefix Count: 6
  Total Redist Count: 2

Automatic Summarization: disabled
Maximum path: 4
Routing for Networks:
  0.0.0.0
Routing Information Sources:
  Gateway         Distance      Last Update
  192.168.9.1     90           00:32:42
Distance: internal 90 external 170
```

Escenario 2

Una empresa de comunicaciones presenta una estructura Core acorde a la topología de red, en donde el estudiante será el administrador de la red, el cual deberá configurar e interconectar entre sí cada uno de los dispositivos que forman parte del escenario, acorde con los lineamientos establecidos para el direccionamiento IP, etherchannels, VLANs y demás aspectos que forman parte del escenario propuesto.

Topología de red:

Figura 22. Escenario 2.



Figura 23. Simulación escenario 2.



Parte 1: Configurar la red de acuerdo con las especificaciones.

a. Apagar todas las interfaces en cada switch.

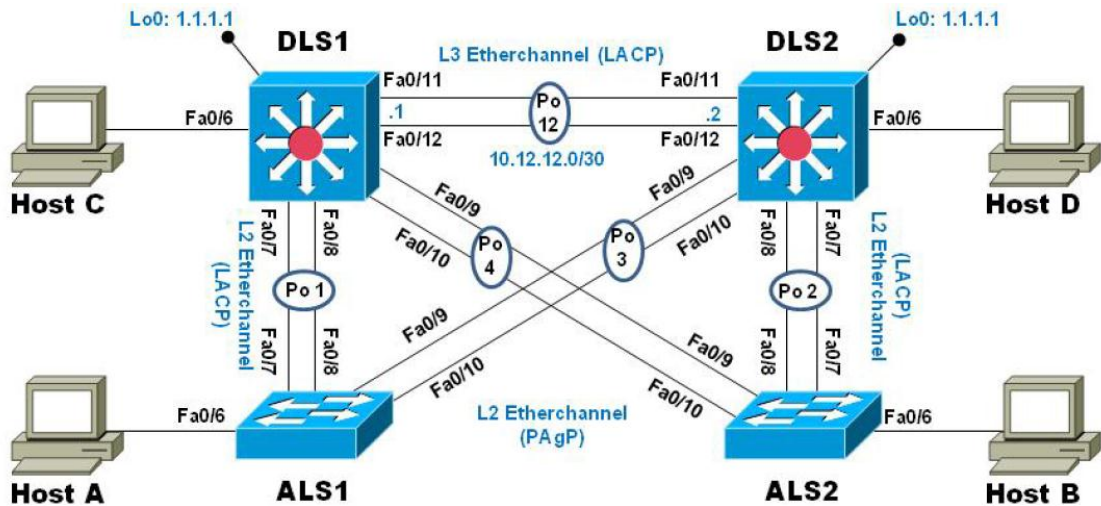
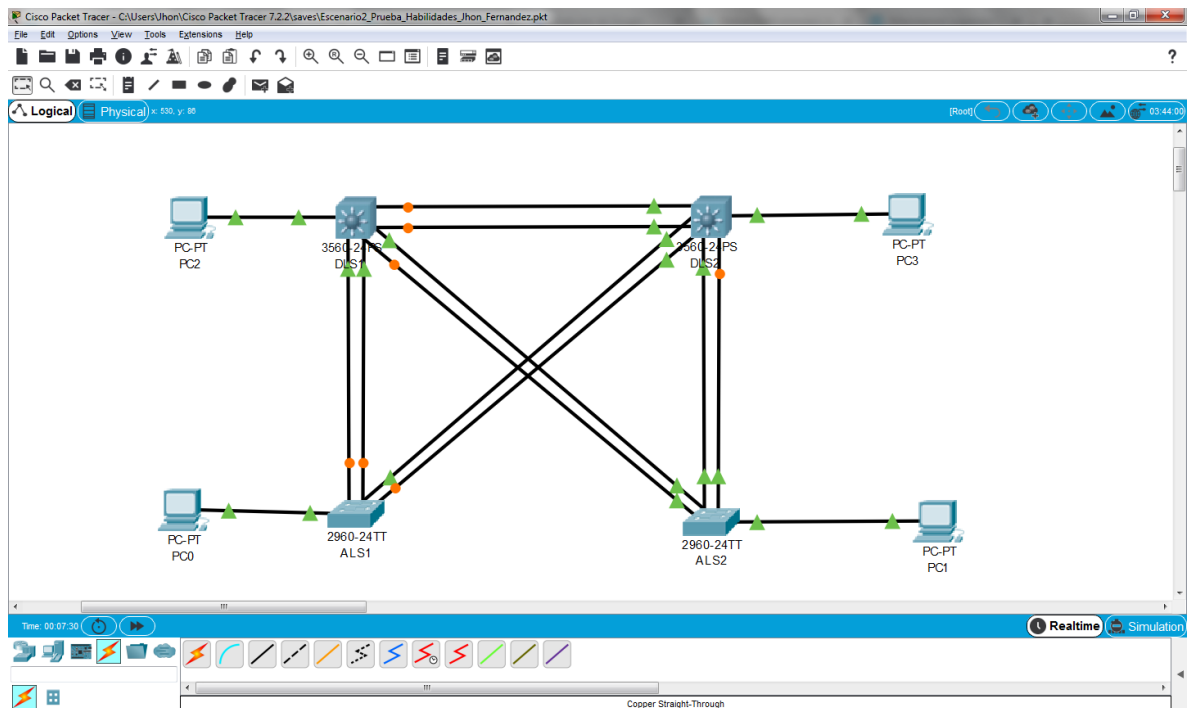
DLS1:

```
Switch#config terminal
Switch(config)#interface range f0/1-24
Switch(config-if-range)#shutdown
Switch(config-if-range)#exit
Switch(config)#
Switch(config)#interface range g0/1-2
Switch(config-if-range)#shutdown
Switch(config-if-range)#exit
Switch(config)#
```

DLS2:

```
Switch#config terminal
Switch(config)#interface range f0/1-24
Switch(config-if-range)#shutdown
Switch(config-if-range)#exit
Switch(config)#
```

```
Switch(config)#interface range g0/1-2
Switch(config-if-range)#shutdown
Switch(config-if-range)#exit
Switch(config)#
```

ALS1:

```
Switch#config terminal
Switch(config)#interface range f0/1-24
Switch(config-if-range)#shutdown
Switch(config-if-range)#exit
Switch(config)#
Switch(config)#interface range g0/1-2
Switch(config-if-range)#shutdown
Switch(config-if-range)#exit
Switch(config)#
```

ALS2:

```
Switch#config terminal
Switch(config)#interface range f0/1-24
Switch(config-if-range)#shutdown
Switch(config-if-range)#exit
Switch(config)#
Switch(config)#interface range g0/1-2
Switch(config-if-range)#shutdown
Switch(config-if-range)#exit
Switch(config)#
```

b. Asignar un nombre a cada switch acorde al escenario establecido.

```
Switch(config)#hostname DLS1
DLS1(config)#
```

```
Switch(config)#hostname DLS2
DLS2(config)#
```

```
Switch(config)#hostname ALS1
ALS1(config)#
```

```
Switch(config)#hostname ALS2
ALS2(config)#
```

c. Configurar los puertos troncales y Port-channels tal como se muestra en el diagrama.

1) La conexión entre DLS1 y DLS2 será un EtherChannel capa-3 utilizando LACP. Para DLS1 se utilizará la dirección IP 10.12.12.1/30 y para DLS2 utilizará 10.12.12.2/30.

```
DLS1(config)#interface range f0/11-12
DLS1(config-if-range)#no switchport
DLS1(config-if-range)#channel-group 12 mode active
DLS1(config-if-range)#no shutdown
DLS1(config-if-range)#exit
DLS1(config)#
DLS1(config)#interface port-channel 12
DLS1(config-if)#ip address 10.12.12.1 255.255.255.252
DLS1(config-if)#no shutdown
DLS1(config-if)#exit
DLS1(config)#
```

```
DLS2(config)#interface range f0/11-12
DLS2(config-if-range)#no switchport
DLS2(config-if-range)#channel-group 12 mode active
DLS2(config-if-range)#no shutdown
DLS2(config-if-range)#exit
DLS2(config)#
DLS2(config)#interface port-channel 12
DLS2(config-if)#ip address 10.12.12.2 255.255.255.252
DLS2(config-if)#no shutdown
DLS2(config-if)#exit
DLS2(config)#
```

2) Los Port-channels en las interfaces Fa0/7 y Fa0/8 utilizarán LACP.

```
DLS1(config)#interface range f0/7-8
DLS1(config-if-range)#switchport trunk encapsulation dot1q
DLS1(config-if-range)#switchport mode trunk
DLS1(config-if-range)#channel-group 1 mode active
DLS1(config-if-range)#no shutdown
DLS1(config-if-range)#exit
DLS1(config)#
```

```
ALS1(config)#interface range f0/7-8
ALS1(config-if-range)#channel-group 1 mode active
ALS1(config-if-range)#switchport mode trunk
ALS1(config-if-range)#no shutdown
ALS1(config-if-range)#exit
ALS1(config)#
```

```
DLS2(config)#interface range f0/7-8
DLS2(config-if-range)#switchport trunk encapsulation dot1q
DLS2(config-if-range)#switchport mode trunk
DLS2(config-if-range)#channel-group 2 mode active
DLS2(config-if-range)#no shutdown
DLS2(config-if-range)#exit
DLS2(config)#
```

```
ALS2(config)#interface range f0/7-8
ALS2(config-if-range)#channel-group 2 mode active
ALS2(config-if-range)#switchport mode trunk
ALS2(config-if-range)#no shutdown
ALS2(config-if-range)#exit
ALS2(config)#
```

3) Los Port-channels en las interfaces F0/9 y fa0/10 utilizará PAgP.

```
DLS1(config)#interface range f0/9-10
DLS1(config-if-range)#switchport trunk encapsulation dot1q
DLS1(config-if-range)#switchport mode trunk
DLS1(config-if-range)#channel-group 4 mode desirable
DLS1(config-if-range)#no shutdown
DLS1(config-if-range)#exit
DLS1(config)#
```

```
ALS2(config)#interface range f0/9-10
ALS2(config-if-range)#channel-group 4 mode desirable
ALS2(config-if-range)#switchport mode trunk
ALS2(config-if-range)#no shutdown
ALS2(config-if-range)#exit
ALS2(config)#
```

```
DLS2(config)#interface range f0/9-10
DLS2(config-if-range)#switchport trunk encapsulation dot1q
DLS2(config-if-range)#switchport mode trunk
DLS2(config-if-range)#channel-group 3 mode desirable
DLS2(config-if-range)#no shutdown
DLS2(config-if-range)#exit
DLS2(config)#
```

```
ALS1(config)#interface range f0/9-10
ALS1(config-if-range)#channel-group 3 mode desirable
ALS1(config-if-range)#switchport mode trunk
ALS1(config-if-range)#no shutdown
ALS1(config-if-range)#exit
```

```
ALS1(config)#
```

4) Todos los puertos troncales serán asignados a la VLAN 800 como la VLAN nativa.

```
DLS1(config)#interface port-channel 1
DLS1(config-if)#switchport trunk native vlan 800
DLS1(config-if)#exit
DLS1(config)#interface port-channel 4
DLS1(config-if)#switchport trunk native vlan 800
DLS1(config-if)#exit
DLS1(config)#
```

```
DLS2(config)#interface port-channel 2
DLS2(config-if)#switchport trunk native vlan 800
DLS2(config-if)#exit
DLS2(config)#interface port-channel 3
DLS2(config-if)#switchport trunk native vlan 800
DLS2(config-if)#exit
DLS2(config)#
```

```
ALS1(config)#interface port-channel 1
ALS1(config-if)#switchport trunk native vlan 800
ALS1(config-if)#exit
ALS1(config)#interface port-channel 3
ALS1(config-if)#switchport trunk native vlan 800
ALS1(config-if)#exit
ALS1(config)#
```

```
ALS2(config-if)#switchport trunk native vlan 800
ALS2(config-if)#exit
ALS2(config)#interface port-channel 4
ALS2(config-if)#switchport trunk native vlan 800
ALS2(config-if)#exit
ALS2(config)#
```

d. Configurar DLS1, ALS1, y ALS2 para utilizar VTP versión 3

1) Utilizar el nombre de dominio UNAD con la contraseña cisco123

```
DLS1(config)#vtp domain UNAD
DLS1(config)#vtp password cisco123
DLS1(config)#vtp version 2
DLS1(config)#
```

```
ALS1(config)#vtp domain UNAD
ALS1(config)#vtp password cisco123
```

```

ALS1(config)#vtp version 2
ALS1(config)#
ALS2(config)#vtp domain UNAD
ALS2(config)#vtp password cisco123
ALS2(config)#vtp version 2
ALS2(config)#

```

Nota: Switch no recibe comando VTP versión 3 se configura en VTP versión 2.

2) Configurar DLS1 como servidor principal para las VLAN.

```

DLS1(config)#vtp mode server
DLS1(config)#

```

Nota: Switch no recibe comando vtp primary vlan.

3) Configurar ALS1 y ALS2 como clientes VTP.

```

ALS1(config)#vtp mode client
ALS1(config)#

```

```

ALS2(config)#vtp mode client
ALS2(config)#

```

e. Configurar en el servidor principal las siguientes VLAN:

Tabla 2. Lista VLANs DLS1.

Número de VLAN	Nombre de VLAN	Número de VLAN	Nombre de VLAN
800	NATIVA	434	ESTACIONAMIENTO
12	EJECUTIVOS	123	MANTENIMIENTO
234	HUESPEDES	1010	VOZ
1111	VIDEONET	3456	ADMINISTRACIÓN

```

DLS1(config)#vlan 800
DLS1(config-vlan)#name NATIVA
DLS1(config-vlan)#vlan 12
DLS1(config-vlan)#name EJECUTIVOS
DLS1(config-vlan)#vlan 234
DLS1(config-vlan)#name HUESPEDES
DLS1(config-vlan)#vlan 11
DLS1(config-vlan)#name VIDEONET
DLS1(config-vlan)#vlan 434

```

```
DLS1(config-vlan)#name ESTACIONAMIENTO
DLS1(config-vlan)#vlan 123
DLS1(config-vlan)#name MANTENIMIENTO
DLS1(config-vlan)#vlan 10
DLS1(config-vlan)#name VOZ
DLS1(config-vlan)#vlan 345
DLS1(config-vlan)#name ADMINISTRACION
DLS1(config-vlan)#exit
DLS1(config)#
```

Nota: las Vlan que acepta el switch son de 1 a 1005. Se cambia la 1010 por 10, la 1111 por 11, y la 3456 por 345.

f. En DLS1, suspender la VLAN 434.

```
DLS1(config)#vlan 434
DLS1(config-vlan)#state suspend
DLS1(config-vlan)#exit
DLS1(config)#
```

Nota: el comando state suspend no es recibido por el switch y por lo tanto la Vlan 434 no será suspendida.

g. Configurar DLS2 en modo VTP transparente VTP utilizando VTP versión 2, y configurar en DLS2 las mismas VLAN que en DLS1.

```
DLS2(config)#vtp mode transparent
DLS2(config)#vtp version 2
DLS2(config)#

DLS2(config)#vlan 800
DLS2(config-vlan)#name NATIVA
DLS2(config-vlan)#vlan 12
DLS2(config-vlan)#name EJECUTIVOS
DLS2(config-vlan)#vlan 234
DLS2(config-vlan)#name HUESPEDES
DLS2(config-vlan)#vlan 11
DLS2(config-vlan)#name VIDEONET
DLS2(config-vlan)#vlan 434
DLS2(config-vlan)#name ESTACIONAMIENTO
DLS2(config-vlan)#vlan 123
DLS2(config-vlan)#name MANTENIMIENTO
DLS2(config-vlan)#vlan 10
DLS2(config-vlan)#name VOZ
DLS2(config-vlan)#vlan 345
```

```
DLS2(config-vlan)#name ADMINISTRACION
DLS2(config-vlan)#exit
DLS2(config)#
```

h. Suspende VLAN 434 en DLS2.

```
DLS2(config)#vlan 434
DLS2(config-vlan)#state suspend
DLS2(config-vlan)#exit
DLS2(config)#
```

Nota: el comando state suspend no es recibido por el switch y por lo tanto la Vlan 434 no será suspendida.

i. En DLS2, crear VLAN 567 con el nombre de CONTABILIDAD. La VLAN de CONTABILIDAD no podrá estar disponible en cualquier otro Switch de la red.

```
DLS2(config)#vlan 567
DLS2(config-vlan)#name CONTABILIDAD
DLS2(config-vlan)#exit
DLS2(config)#
DLS2(config)#interface port-channel 2
DLS2(config-if)#switchport trunk allowed vlan except 567
DLS2(config-if)#exit
DLS2(config)#interface port-channel 3
DLS2(config-if)#switchport trunk allowed vlan except 567
DLS2(config-if)#exit
DLS2(config)#
```

j. Configurar DLS1 como Spanning tree root para las VLAN 1, 12, 434, 800, 1010, 1111 y 3456 y como raíz secundaria para las VLAN 123 y 234.

```
DLS1(config)#spanning-tree vlan 1,12,434,800,10,11,345 root primary
DLS1(config)#spanning-tree vlan 123,234 root secondary
DLS1(config)#
```

k. Configurar DLS2 como Spanning tree root para las VLAN 123 y 234 y como una raíz secundaria para las VLAN 12, 434, 800, 1010, 1111 y 3456.

```
DLS2(config)#spanning-tree vlan 123,234 root primary
DLS2(config)#spanning-tree vlan 12,434,800,10,11,345 root secondary
DLS2(config)#
```

l. Configurar todos los puertos como troncales de tal forma que solamente las VLAN que se han creado se les permitirá circular a través de éstos puertos.

```
DLS1(config)#interface port-channel 1
```

```
DLS1(config-if)#switchport trunk allowed vlan 12,123,234,434,800,10,11,345
DLS1(config-if)#exit
DLS1(config)#interface port-channel 4
DLS1(config-if)#switchport trunk allowed vlan 12,123,234,434,800,10,11,345
DLS1(config-if)#exit
DLS1(config)#
```

```
DLS2(config)#interface port-channel 2
DLS2(config-if)#switchport trunk allowed vlan 12,123,234,434,800,10,11,345
DLS2(config-if)#exit
DLS2(config)#interface port-channel 3
DLS2(config-if)#switchport trunk allowed vlan 12,123,234,434,800,10,11,345
DLS2(config-if)#exit
DLS2(config)#
```

```
ALS1(config)#interface port-channel 1
ALS1(config-if)#switchport trunk allowed vlan 12,123,234,434,800,10,11,345
ALS1(config-if)#exit
ALS1(config)#interface port-channel 3
ALS1(config-if)#switchport trunk allowed vlan 12,123,234,434,800,10,11,345
ALS1(config-if)#exit
ALS1(config)#
```

```
ALS2(config)#interface port-channel 4
ALS2(config-if)#switchport trunk allowed vlan 12,123,234,434,800,10,11,345
ALS2(config-if)#exit
ALS2(config)#interface port-channel 2
ALS2(config-if)#switchport trunk allowed vlan 12,123,234,434,800,10,11,345
ALS2(config-if)#exit
ALS2(config)#
```

m. Configurar las siguientes interfaces como puertos de acceso, asignados a las VLAN de la siguiente manera:

Tabla 3. Lista interfaces para acceso a VLANs.

Interfaz	DLS1	DLS2	ALS1	ALS2
Interfaz Fa0/6	3456	12 , 1010	123, 1010	234
Interfaz Fa0/15	1111	1111	1111	1111
Interfaces F0 /16-18		567		

```
DLS1(config)#interface f0/6
```

```
DLS1(config-if)#switchport
DLS1(config-if)#switchport mode access
DLS1(config-if)#switchport access vlan 345
DLS1(config-if)#spanning-tree portfast
DLS1(config-if)#no shutdown
DLS1(config-if)#exit
DLS1(config)#
```

```
DLS1(config)#interface F0/15
DLS1(config-if)#switchport
DLS1(config-if)#switchport mode access
DLS1(config-if)#switchport access vlan 11
DLS1(config-if)#spanning-tree portfast
DLS1(config-if)#exit
DLS1(config)#
```

Nota: switch no recibe comando switchport host.

```
DLS2(config)#interface f0/6
DLS2(config-if)#switchport
DLS2(config-if)#switchport mode access
DLS2(config-if)#switchport access vlan 10
DLS2(config-if)#spanning-tree portfast
DLS2(config-if)#exit
DLS2(config)#
```

Nota: El Switch solo permite el acceso a una vlan. Se configura la 10 y se descarta la 12.

```
DLS2(config)#interface f0/15
DLS2(config-if)#switchport
DLS2(config-if)#switchport mode access
DLS2(config-if)#switchport access vlan 11
DLS2(config-if)#spanning-tree portfast
DLS2(config-if)#exit
DLS2(config)#
```

```
DLS2(config)#interface range f0/16-18
DLS2(config-if-range)#switchport
DLS2(config-if-range)#switchport mode access
DLS2(config-if-range)#switchport access vlan 567
DLS2(config-if-range)#spanning-tree portfast
DLS2(config-if-range)#exit
DLS2(config)#
```

Nota: switch no recibe comando switchport host.

```
ALS1(config)#interface f0/6
ALS1(config-if)#switchport
ALS1(config-if)#switchport mode access
ALS1(config-if)#switchport access vlan 123
ALS1(config-if)#spanning-tree portfast
ALS1(config-if)#no shutdown
ALS1(config-if)#exit
ALS1(config)#
```

Nota: El switch solo permite el acceso a una vlan. Se configuro la 123 y se descarta la 10.

```
ALS1(config)#interface f0/15
ALS1(config-if)#switchport
ALS1(config-if)#switchport mode access
ALS1(config-if)#switchport access vlan 11
ALS1(config-if)#spanning-tree portfast
ALS1(config-if)#no shutdown
ALS1(config-if)#exit
ALS1(config)#
```

Nota: switch no recibe comando switchport host.

```
ALS2(config)#interface f0/6
ALS2(config-if)#switchport
ALS2(config-if)#switchport mode access
ALS2(config-if)#switchport access vlan 234
ALS2(config-if)#spanning-tree portfast
ALS2(config-if)#no shutdown
ALS2(config-if)#exit
ALS2(config)#
```

```
ALS2(config)#interface f0/15
ALS2(config-if)#switchport
ALS2(config-if)#switchport mode access
ALS2(config-if)#switchport access vlan 11
ALS2(config-if)#spanning-tree portfast
ALS2(config-if)#no shutdown
ALS2(config-if)#exit
ALS2(config)#
```

Nota: switch no recibe comando switchport host.

Part 2: conectividad de red de prueba y las opciones configuradas.

a. Verificar la existencia de las VLAN correctas en todos los switches y la asignación de puertos troncales y de acceso

Figura 24. Comando show interface trunk DLS1.

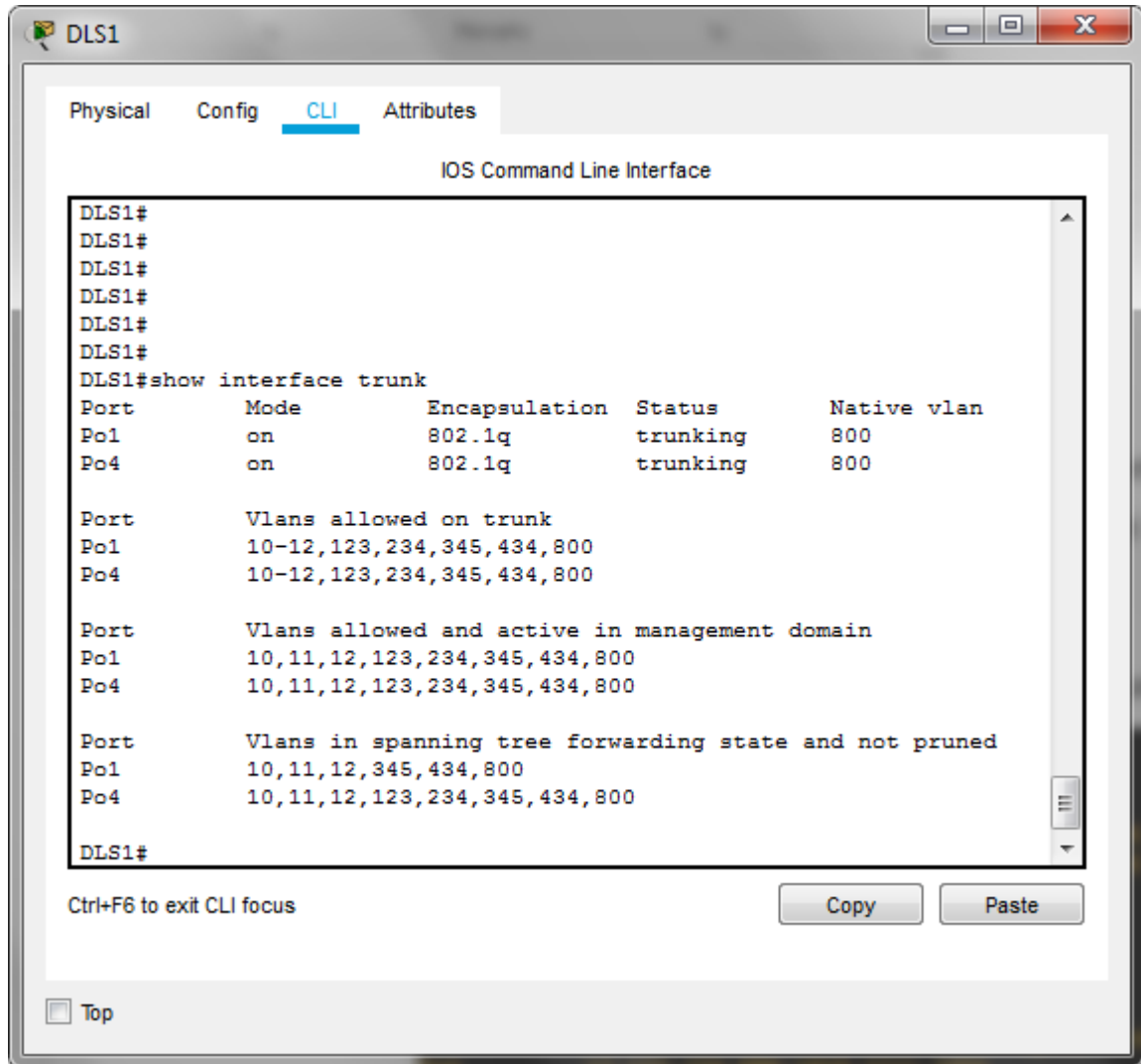

The screenshot shows a window titled 'DLS1' with tabs for 'Physical', 'Config', 'CLI', and 'Attributes'. The 'CLI' tab is active, displaying the 'IOS Command Line Interface'. The terminal output shows the command 'show interface trunk' and its results for ports Po1 and Po4.

```
DLS1#  
DLS1#  
DLS1#  
DLS1#  
DLS1#  
DLS1#  
DLS1#show interface trunk  
Port          Mode          Encapsulation  Status        Native vlan  
Po1           on            802.1q         trunking      800  
Po4           on            802.1q         trunking      800  
  
Port          Vlans allowed on trunk  
Po1          10-12,123,234,345,434,800  
Po4          10-12,123,234,345,434,800  
  
Port          Vlans allowed and active in management domain  
Po1          10,11,12,123,234,345,434,800  
Po4          10,11,12,123,234,345,434,800  
  
Port          Vlans in spanning tree forwarding state and not pruned  
Po1          10,11,12,345,434,800  
Po4          10,11,12,123,234,345,434,800  
  
DLS1#
```

Below the terminal output, there is a prompt 'Ctrl+F6 to exit CLI focus' and two buttons: 'Copy' and 'Paste'. At the bottom left, there is a 'Top' button.

Figura 25. Comando show interface trunk DLS2.



Figura 26. Comando show interface trunk ALS1.



Figura 27. Comando show interface trunk ALS2.

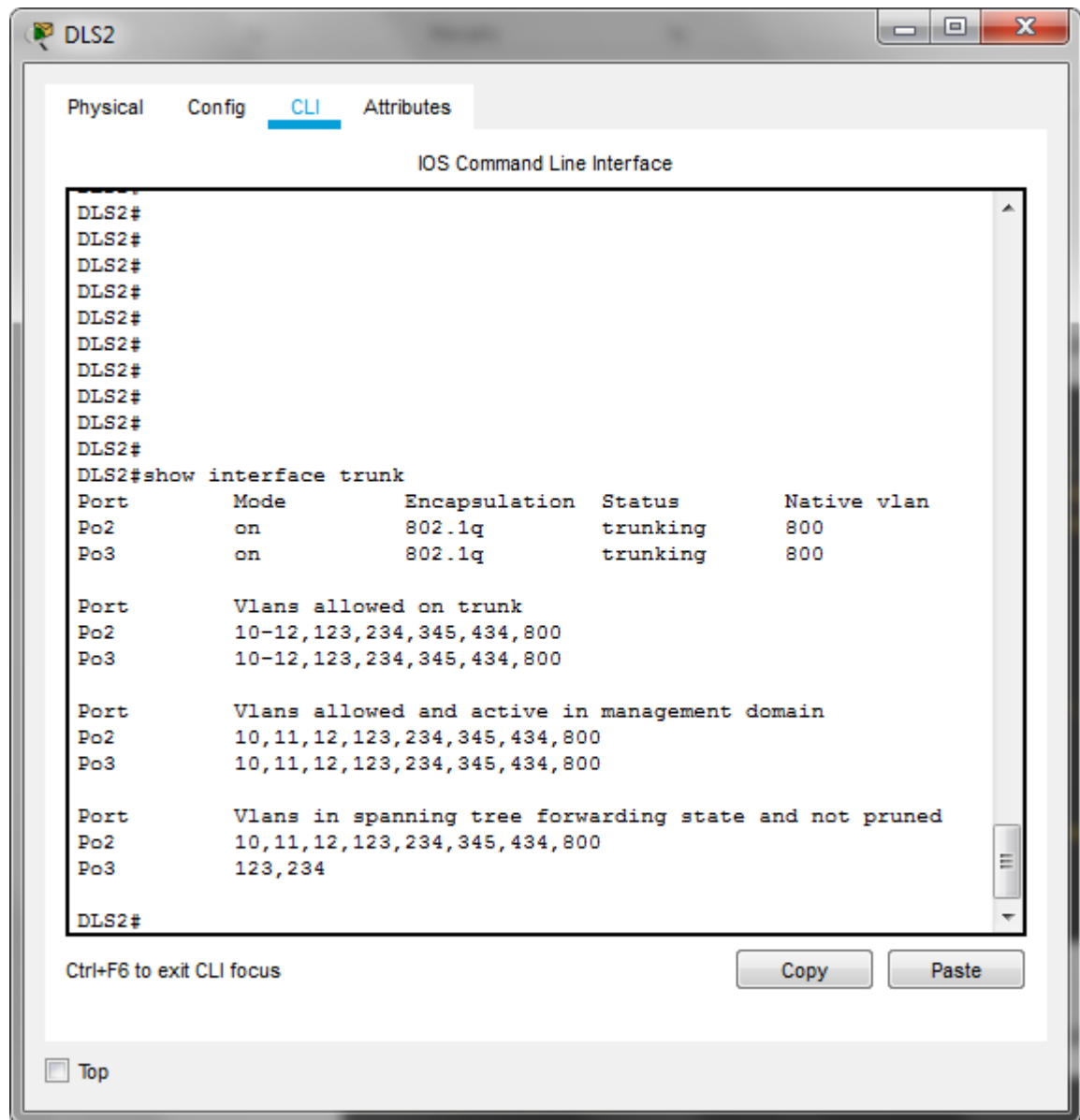

b. Verificar que el EtherChannel entre DLS1 y ALS1 está configurado correctamente.

Figura 28. Comando show etherchannel summary DLS1

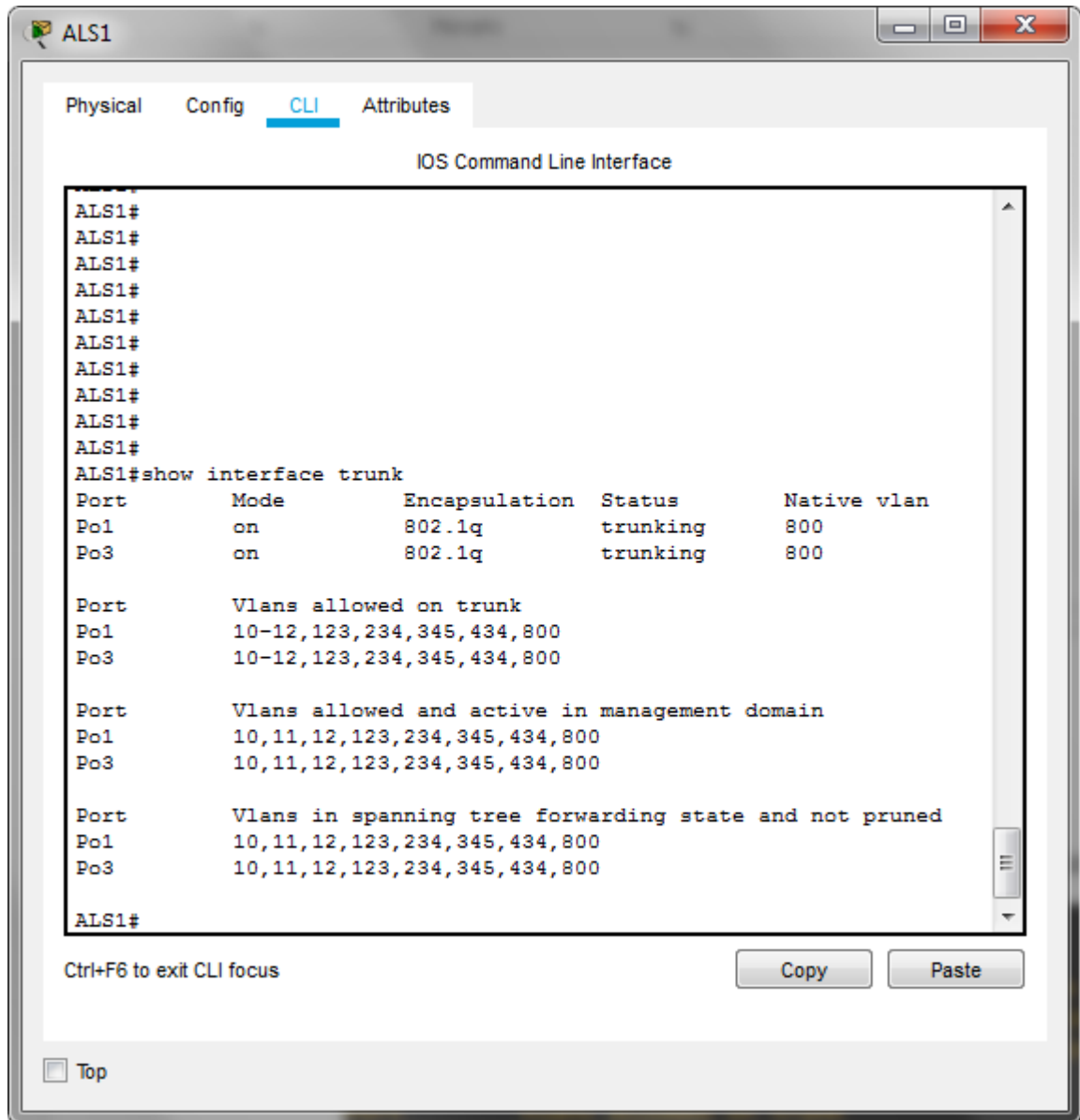
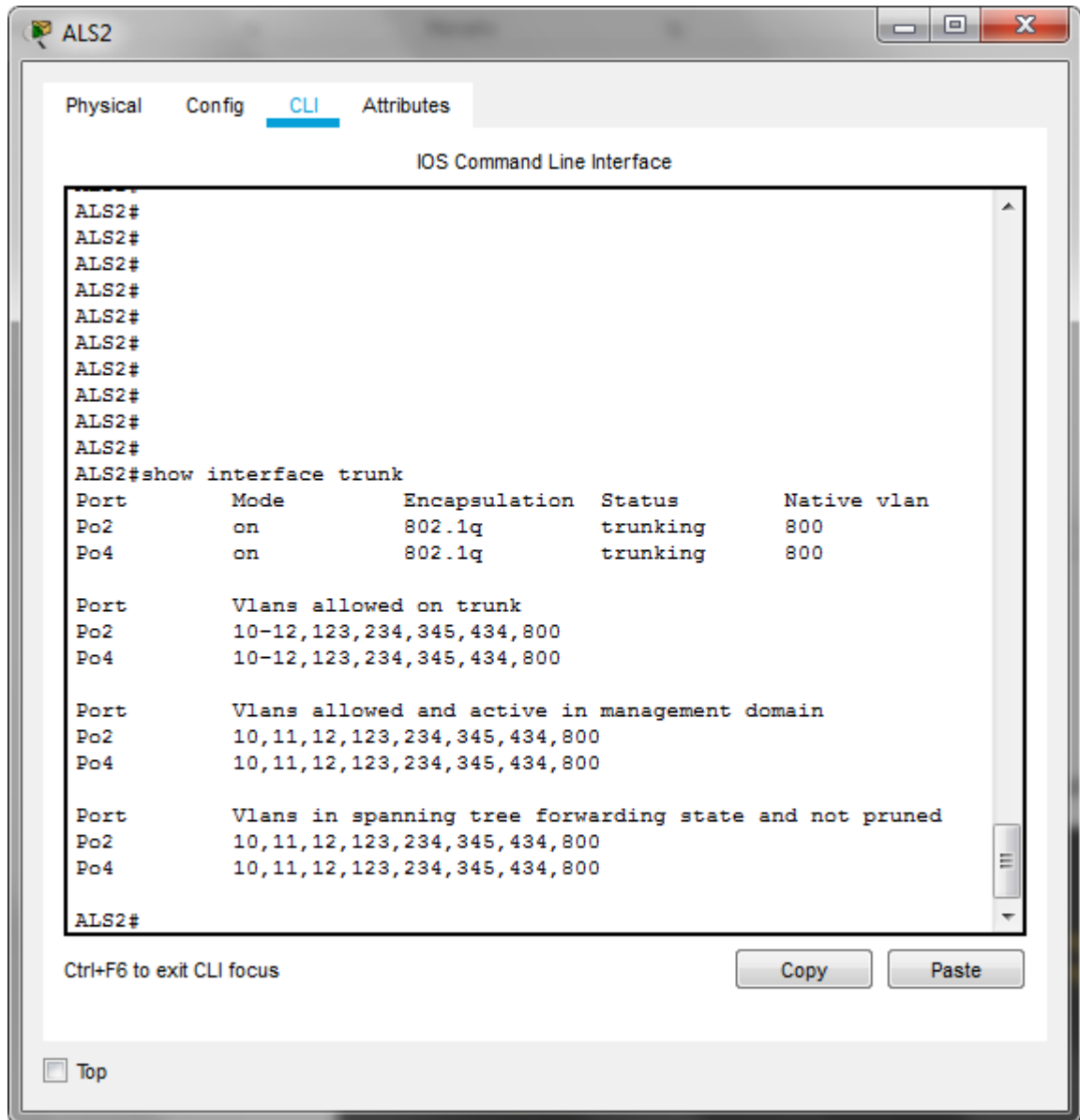
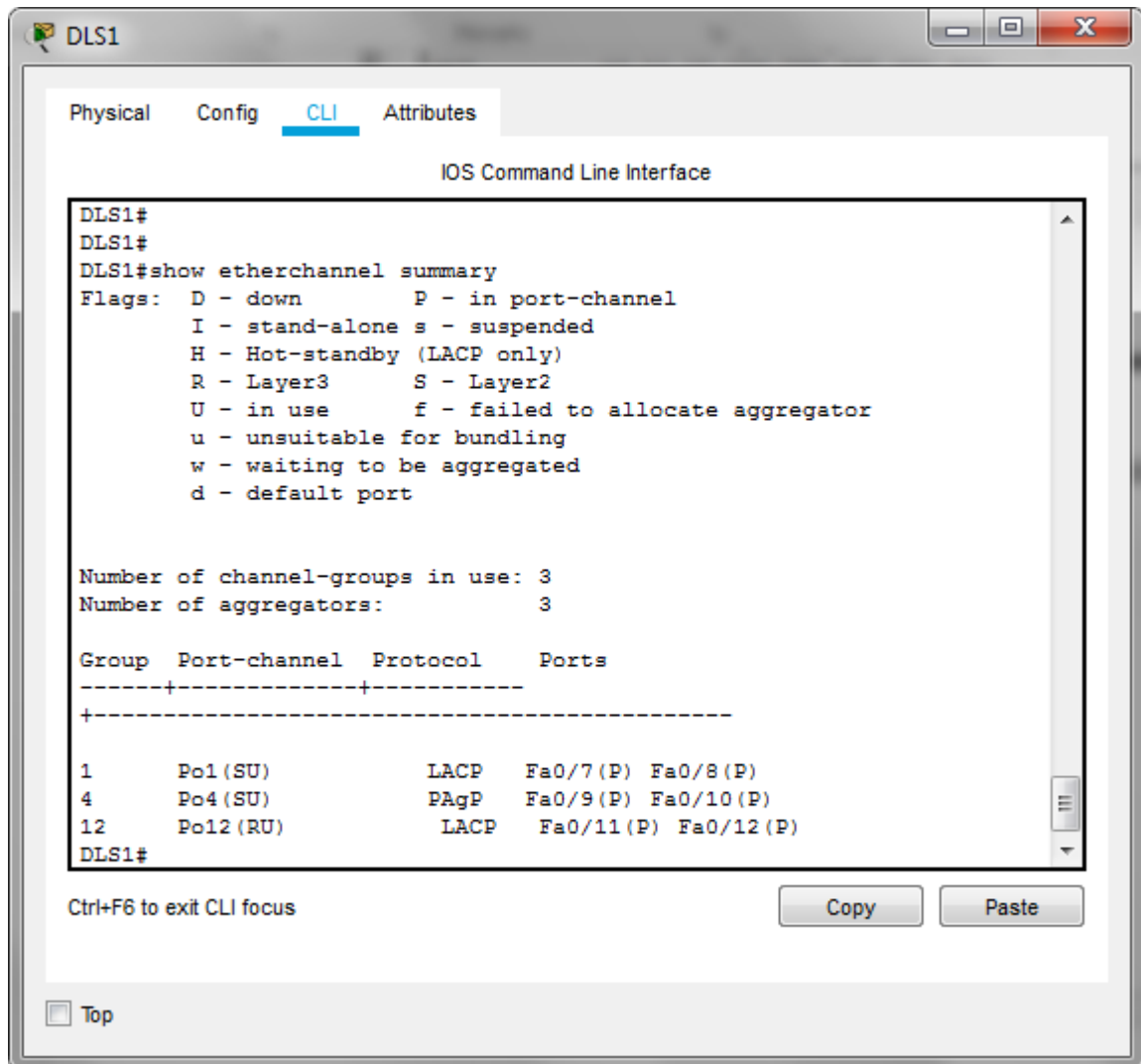

The screenshot shows a terminal window titled 'DLS1' with tabs for 'Physical', 'Config', 'CLI', and 'Attributes'. The 'CLI' tab is active, displaying the 'IOS Command Line Interface'. The user has entered the command 'show etherchannel summary'. The output shows the flags for EtherChannel, the number of channel-groups in use (3) and aggregators (3), and a table of channel groups.

```
DLS1#
DLS1#
DLS1#show etherchannel summary
Flags: D - down          P - in port-channel
       I - stand-alone  s - suspended
       H - Hot-standby (LACP only)
       R - Layer3       S - Layer2
       U - in use       f - failed to allocate aggregator
       u - unsuitable for bundling
       w - waiting to be aggregated
       d - default port

Number of channel-groups in use: 3
Number of aggregators:          3

Group  Port-channel  Protocol    Ports
-----+-----+-----
+-----+-----+-----
1      Po1 (SU)       LACP       Fa0/7 (P) Fa0/8 (P)
4      Po4 (SU)       PAgP       Fa0/9 (P) Fa0/10 (P)
12     Po12 (RU)      LACP       Fa0/11 (P) Fa0/12 (P)
DLS1#
```

Ctrl+F6 to exit CLI focus

Copy Paste

Top

Figura 29. Comando show etherchannel summary ALS1.

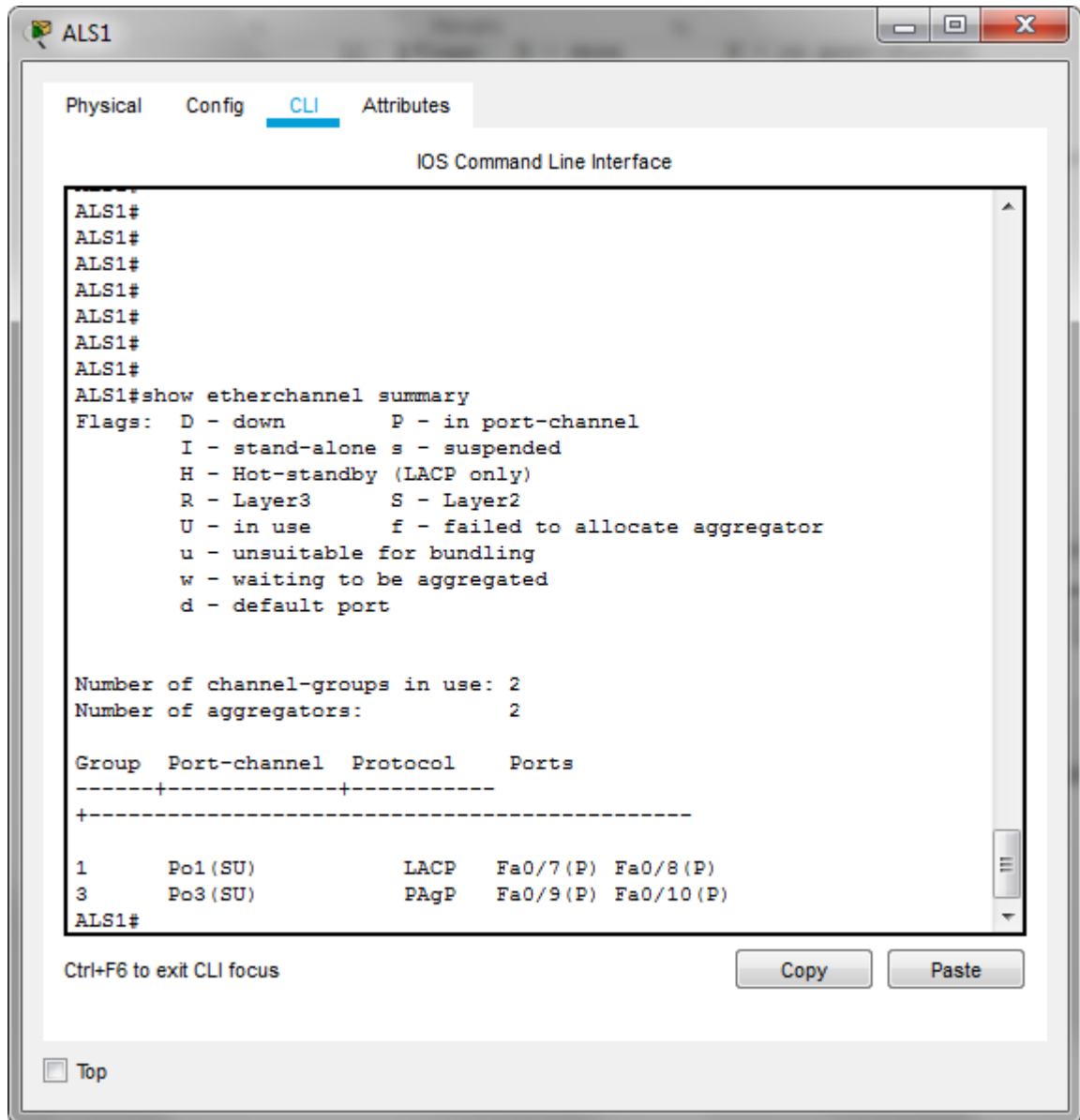

c. Verificar la configuración de Spanning tree entre DLS1 o DLS2 para cada VLAN.
DLS1:

Figura 30. Comando show spanning-tree DLS1 parte 1.

DLS1

Physical Config **CLI** Attributes

IOS Command Line Interface

```
DLS1#show spanning-tree
VLAN0001
  Spanning tree enabled protocol ieee
  Root ID    Priority    24577
            Address    00D0.D369.A99C
            This bridge is the root
            Hello Time 2 sec  Max Age 20 sec  Forward Delay 15 sec

  Bridge ID  Priority    24577 (priority 24576 sys-id-ext 1)
            Address    00D0.D369.A99C
            Hello Time 2 sec  Max Age 20 sec  Forward Delay 15 sec
            Aging Time 20

Interface          Role Sts Cost          Prio.Nbr Type
-----
Po4                Desg FWD 9           128.29 Shr
Po1                Desg FWD 9           128.28 Shr

VLAN0010
  Spanning tree enabled protocol ieee
  Root ID    Priority    24586
            Address    00D0.D369.A99C
            This bridge is the root
            Hello Time 2 sec  Max Age 20 sec  Forward Delay 15 sec

  Bridge ID  Priority    24586 (priority 24576 sys-id-ext 10)
            Address    00D0.D369.A99C
            Hello Time 2 sec  Max Age 20 sec  Forward Delay 15 sec
            Aging Time 20

Interface          Role Sts Cost          Prio.Nbr Type
-----
Po4                Desg FWD 9           128.29 Shr
Fa0/9              Desg FWD 19          128.9   P2p
Fa0/10             Desg FWD 19          128.10 P2p
Fa0/7              Desg FWD 19          128.7   P2p
Fa0/8              Desg FWD 19          128.8   P2p
Po1                Desg FWD 9           128.28 Shr

VLAN0011
  Spanning tree enabled protocol ieee
  Root ID    Priority    24587
            Address    00D0.D369.A99C
            This bridge is the root
  --More--
```

Ctrl+F6 to exit CLI focus

Copy Paste

Top

Figura 31. Comando show spanning-tree DLS1 parte 2.

The screenshot shows a CLI window titled 'DLS1' with tabs for Physical, Config, CLI (selected), and Attributes. The main content is the output of the 'show spanning-tree' command, displaying details for three VLANs: the root bridge, VLAN0012, and VLAN0013. Each VLAN entry includes its role (root or designated), priority, MAC address, and a table of interfaces with their roles and costs.

```

IOS Command Line Interface

This bridge is the root
Hello Time 2 sec Max Age 20 sec Forward Delay 15 sec

Bridge ID Priority 24587 (priority 24576 sys-id-ext 11)
Address 00D0.D369.A99C
Hello Time 2 sec Max Age 20 sec Forward Delay 15 sec
Aging Time 20

Interface      Role Sts Cost      Prio.Nbr Type
-----
Po4            Desg FWD 9         128.29  Shr
Fa0/9         Desg FWD 19        128.9   P2p
Fa0/10        Desg FWD 19        128.10  P2p
Fa0/7         Desg FWD 19        128.7   P2p
Fa0/8         Desg FWD 19        128.8   P2p
Po1           Desg FWD 9         128.28  Shr

VLAN0012
Spanning tree enabled protocol ieee
Root ID Priority 24588
Address 00D0.D369.A99C
This bridge is the root
Hello Time 2 sec Max Age 20 sec Forward Delay 15 sec

Bridge ID Priority 24588 (priority 24576 sys-id-ext 12)
Address 00D0.D369.A99C
Hello Time 2 sec Max Age 20 sec Forward Delay 15 sec
Aging Time 20

Interface      Role Sts Cost      Prio.Nbr Type
-----
Po4            Desg FWD 9         128.29  Shr
Fa0/9         Desg FWD 19        128.9   P2p
Fa0/10        Desg FWD 19        128.10  P2p
Fa0/7         Desg FWD 19        128.7   P2p
Fa0/8         Desg FWD 19        128.8   P2p
Po1           Desg FWD 9         128.28  Shr

VLAN0013
Spanning tree enabled protocol ieee
Root ID Priority 24699
Address 0001.439E.BC59
Cost 18
Port 29 (Port-channel4)

--More--
  
```

At the bottom of the window, there is a 'Ctrl+F6 to exit CLI focus' message, 'Copy' and 'Paste' buttons, and a 'Top' button.

Figura 32. Comando show spanning-tree DLS1 parte 3.

The screenshot shows a CLI window titled 'DLS1' with tabs for Physical, Config, CLI (selected), and Attributes. The main content is the 'IOS Command Line Interface' displaying the output of the 'show spanning-tree' command for two VLANs.

VLAN0123

```
Spanning tree enabled protocol ieee
Root ID    Priority    24699
           Address    0001.439E.BC59
           Cost      18
           Port      29(Port-channel4)
           Hello Time 2 sec  Max Age 20 sec  Forward Delay 15 sec

Bridge ID  Priority    28795 (priority 28672 sys-id-ext 123)
           Address    00D0.D369.A99C
           Hello Time 2 sec  Max Age 20 sec  Forward Delay 15 sec
           Aging Time 20
```

Interface	Role	Sts	Cost	Prio.Nbr	Type
Po4	Root	FWD	9	128.29	Shr
Fa0/9	Desg	FWD	19	128.9	P2p
Fa0/10	Desg	FWD	19	128.10	P2p
Fa0/7	Desg	FWD	19	128.7	P2p
Fa0/8	Desg	FWD	19	128.8	P2p
Po1	Altn	BLK	9	128.28	Shr

VLAN0234

```
Spanning tree enabled protocol ieee
Root ID    Priority    24810
           Address    0001.439E.BC59
           Cost      18
           Port      29(Port-channel4)
           Hello Time 2 sec  Max Age 20 sec  Forward Delay 15 sec

Bridge ID  Priority    28906 (priority 28672 sys-id-ext 234)
           Address    00D0.D369.A99C
           Hello Time 2 sec  Max Age 20 sec  Forward Delay 15 sec
           Aging Time 20
```

Interface	Role	Sts	Cost	Prio.Nbr	Type
Po4	Root	FWD	9	128.29	Shr
Fa0/9	Desg	FWD	19	128.9	P2p
Fa0/10	Desg	FWD	19	128.10	P2p
Fa0/7	Desg	FWD	19	128.7	P2p
Fa0/8	Desg	FWD	19	128.8	P2p
Po1	Altn	BLK	9	128.28	Shr

At the bottom of the window, there is a 'Ctrl+F6 to exit CLI focus' message, 'Copy' and 'Paste' buttons, and a 'Top' button.

Figura 33. Comando show spanning-tree DLS1 parte 4.

The screenshot shows a CLI window titled 'DLS1' with tabs for Physical, Config, CLI (selected), and Attributes. The main content is the 'IOS Command Line Interface' output for the 'show spanning-tree' command. It displays details for three VLANs: 0345, 0434, and 0800. Each VLAN entry includes the spanning tree protocol status, root ID, priority, address, and a table of interface roles and costs.

```

VLAN0345
Spanning tree enabled protocol ieee
Root ID    Priority    24921
           Address    00D0.D369.A99C
           This bridge is the root
           Hello Time 2 sec Max Age 20 sec Forward Delay 15 sec

Bridge ID  Priority    24921 (priority 24576 sys-id-ext 345)
           Address    00D0.D369.A99C
           Hello Time 2 sec Max Age 20 sec Forward Delay 15 sec
           Aging Time 20

Interface    Role Sts Cost        Prio.Nbr Type
-----
Po4          Desg FWD 9          128.29 Shr
Fa0/9       Desg FWD 19         128.9  P2p
Fa0/10      Desg FWD 19         128.10 P2p
Fa0/6       Desg FWD 19         128.6  P2p
Fa0/7       Desg FWD 19         128.7  P2p
Fa0/8       Desg FWD 19         128.8  P2p
Po1         Desg FWD 9          128.28 Shr

VLAN0434
Spanning tree enabled protocol ieee
Root ID    Priority    25010
           Address    00D0.D369.A99C
           This bridge is the root
           Hello Time 2 sec Max Age 20 sec Forward Delay 15 sec

Bridge ID  Priority    25010 (priority 24576 sys-id-ext 434)
           Address    00D0.D369.A99C
           Hello Time 2 sec Max Age 20 sec Forward Delay 15 sec
           Aging Time 20

Interface    Role Sts Cost        Prio.Nbr Type
-----
Po4          Desg FWD 9          128.29 Shr
Fa0/9       Desg FWD 19         128.9  P2p
Fa0/10      Desg FWD 19         128.10 P2p
Fa0/7       Desg FWD 19         128.7  P2p
Fa0/8       Desg FWD 19         128.8  P2p
Po1         Desg FWD 9          128.28 Shr

VLAN0800
--More--
  
```

At the bottom of the CLI window, there is a prompt 'Ctrl+F6 to exit CLI focus' and two buttons: 'Copy' and 'Paste'. A 'Top' button is also visible in the bottom left corner.

Figura 34. Comando show spanning-tree DLS1 parte 5.

The screenshot shows a CLI window titled 'DLS1' with tabs for Physical, Config, CLI (selected), and Attributes. The main content is the 'IOS Command Line Interface' displaying the output of the 'show spanning-tree' command for two VLANs: VLAN0434 and VLAN0800.

VLAN0434

```
Spanning tree enabled protocol ieee
Root ID    Priority    25010
           Address    00D0.D369.A99C
           This bridge is the root
           Hello Time 2 sec  Max Age 20 sec  Forward Delay 15 sec

Bridge ID  Priority    25010 (priority 24576 sys-id-ext 434)
           Address    00D0.D369.A99C
           Hello Time 2 sec  Max Age 20 sec  Forward Delay 15 sec
           Aging Time 20
```

Interface	Role	Sts	Cost	Prio.Nbr	Type
Po4	Desg	FWD	9	128.29	Shr
Fa0/9	Desg	FWD	19	128.9	P2p
Fa0/10	Desg	FWD	19	128.10	P2p
Fa0/7	Desg	FWD	19	128.7	P2p
Fa0/8	Desg	FWD	19	128.8	P2p
Po1	Desg	FWD	9	128.28	Shr

VLAN0800

```
Spanning tree enabled protocol ieee
Root ID    Priority    25376
           Address    00D0.D369.A99C
           This bridge is the root
           Hello Time 2 sec  Max Age 20 sec  Forward Delay 15 sec

Bridge ID  Priority    25376 (priority 24576 sys-id-ext 800)
           Address    00D0.D369.A99C
           Hello Time 2 sec  Max Age 20 sec  Forward Delay 15 sec
           Aging Time 20
```

Interface	Role	Sts	Cost	Prio.Nbr	Type
Po4	Desg	FWD	9	128.29	Shr
Fa0/9	Desg	FWD	19	128.9	P2p
Fa0/10	Desg	FWD	19	128.10	P2p
Fa0/7	Desg	FWD	19	128.7	P2p
Fa0/8	Desg	FWD	19	128.8	P2p
Po1	Desg	FWD	9	128.28	Shr

DLS1#
DLS1#

Ctrl+F6 to exit CLI focus

Copy Paste

Top

DLS2:

Figura 35. Comando show spanning-tree DLS2 parte 1.

The screenshot shows a terminal window titled 'DLS2' with tabs for 'Physical', 'Config', 'CLI', and 'Attributes'. The 'CLI' tab is active, displaying the 'IOS Command Line Interface'. The command 'DLS2#show spanning-tree' has been executed, showing the following output:

```
DLS2#show spanning-tree
VLAN0001
  Spanning tree enabled protocol ieee
  Root ID    Priority    24577
            Address    00D0.D369.A99C
            Cost      18
            Port      28(Port-channel2)
            Hello Time 2 sec  Max Age 20 sec  Forward Delay 15 sec

  Bridge ID  Priority    32769 (priority 32768 sys-id-ext 1)
            Address    0001.439E.BC59
            Hello Time 2 sec  Max Age 20 sec  Forward Delay 15 sec
            Aging Time 20

Interface          Role Sts Cost      Prio.Nbr Type
-----
Po3                 Altn BLK 9         128.29  Shr
Po2                 Root FWD 9         128.28  Shr

VLAN0010
  Spanning tree enabled protocol ieee
  Root ID    Priority    24586
            Address    00D0.D369.A99C
            Cost      18
            Port      28(Port-channel2)
            Hello Time 2 sec  Max Age 20 sec  Forward Delay 15 sec

  Bridge ID  Priority    28682 (priority 28672 sys-id-ext 10)
            Address    0001.439E.BC59
            Hello Time 2 sec  Max Age 20 sec  Forward Delay 15 sec
            Aging Time 20

Interface          Role Sts Cost      Prio.Nbr Type
-----
Fa0/6              Desg FWD 19        128.6   P2p
Fa0/7              Desg FWD 19        128.7   P2p
Fa0/8              Desg FWD 19        128.8   P2p
Fa0/9              Desg FWD 19        128.9   P2p
Fa0/10             Desg FWD 19        128.10  P2p
Po3                 Altn BLK 9         128.29  Shr
Po2                 Root FWD 9         128.28  Shr

VLAN0011
  Spanning tree enabled protocol ieee
  --More--
```

At the bottom of the window, there is a 'Ctrl+F6 to exit CLI focus' message, 'Copy' and 'Paste' buttons, and a 'Top' button.

Figura 36. Comando show spanning-tree DLS2 parte 2.

The screenshot shows a terminal window titled 'DLS2' with tabs for 'Physical', 'Config', 'CLI', and 'Attributes'. The 'CLI' tab is active, displaying the output of the 'show spanning-tree' command for three VLANs: VLAN0011, VLAN0012, and VLAN0123. The output is organized into sections for each VLAN, including root and bridge information and a table of interface roles.

VLAN0011

```
Spanning tree enabled protocol ieee
Root ID    Priority    24587
           Address    00D0.D369.A99C
           Cost      18
           Port      28 (Port-channel2)
           Hello Time 2 sec  Max Age 20 sec  Forward Delay 15 sec

Bridge ID  Priority    28683 (priority 28672 sys-id-ext 11)
           Address    0001.439E.BC59
           Hello Time 2 sec  Max Age 20 sec  Forward Delay 15 sec
           Aging Time 20
```

Interface	Role	Sts	Cost	Prio.Nbr	Type
Fa0/7	Desg	FWD	19	128.7	P2p
Fa0/8	Desg	FWD	19	128.8	P2p
Fa0/9	Desg	FWD	19	128.9	P2p
Fa0/10	Desg	FWD	19	128.10	P2p
Po3	Altn	BLK	9	128.29	Shr
Po2	Root	FWD	9	128.28	Shr

VLAN0012

```
Spanning tree enabled protocol ieee
Root ID    Priority    24588
           Address    00D0.D369.A99C
           Cost      18
           Port      28 (Port-channel2)
           Hello Time 2 sec  Max Age 20 sec  Forward Delay 15 sec

Bridge ID  Priority    28684 (priority 28672 sys-id-ext 12)
           Address    0001.439E.BC59
           Hello Time 2 sec  Max Age 20 sec  Forward Delay 15 sec
           Aging Time 20
```

Interface	Role	Sts	Cost	Prio.Nbr	Type
Fa0/7	Desg	FWD	19	128.7	P2p
Fa0/8	Desg	FWD	19	128.8	P2p
Fa0/9	Desg	FWD	19	128.9	P2p
Fa0/10	Desg	FWD	19	128.10	P2p
Po3	Altn	BLK	9	128.29	Shr
Po2	Root	FWD	9	128.28	Shr

VLAN0123

At the bottom of the terminal window, there is a prompt 'Ctrl+F6 to exit CLI focus' and two buttons labeled 'Copy' and 'Paste'. A 'Top' button is also visible in the bottom left corner of the window frame.

Figura 37. Comando show spanning-tree DLS2 parte 3.

The screenshot shows a CLI window titled 'DLS2' with tabs for Physical, Config, CLI (selected), and Attributes. The main content is the 'IOS Command Line Interface' output for the 'show spanning-tree' command. It displays details for three VLANs: VLAN0123, VLAN0234, and VLAN0345. Each VLAN entry includes the spanning tree protocol status, root and bridge IDs with their priorities and MAC addresses, and a table of interfaces with their roles, statuses, costs, and priorities.

```
VLAN0123
Spanning tree enabled protocol ieee
Root ID    Priority    24699
           Address    0001.439E.BC59
           This bridge is the root
           Hello Time 2 sec Max Age 20 sec Forward Delay 15 sec

Bridge ID  Priority    24699 (priority 24576 sys-id-ext 123)
           Address    0001.439E.BC59
           Hello Time 2 sec Max Age 20 sec Forward Delay 15 sec
           Aging Time 20

Interface      Role Sts Cost      Prio.Nbr Type
-----
Fa0/7          Desg FWD 19        128.7    P2p
Fa0/8          Desg FWD 19        128.8    P2p
Fa0/9          Desg FWD 19        128.9    P2p
Fa0/10         Desg FWD 19        128.10   P2p
Po3            Desg FWD 9         128.29   Shr
Po2            Desg FWD 9         128.28   Shr

VLAN0234
Spanning tree enabled protocol ieee
Root ID    Priority    24810
           Address    0001.439E.BC59
           This bridge is the root
           Hello Time 2 sec Max Age 20 sec Forward Delay 15 sec

Bridge ID  Priority    24810 (priority 24576 sys-id-ext 234)
           Address    0001.439E.BC59
           Hello Time 2 sec Max Age 20 sec Forward Delay 15 sec
           Aging Time 20

Interface      Role Sts Cost      Prio.Nbr Type
-----
Fa0/7          Desg FWD 19        128.7    P2p
Fa0/8          Desg FWD 19        128.8    P2p
Fa0/9          Desg FWD 19        128.9    P2p
Fa0/10         Desg FWD 19        128.10   P2p
Po3            Desg FWD 9         128.29   Shr
Po2            Desg FWD 9         128.28   Shr

VLAN0345
Spanning tree enabled protocol ieee
--More--
```

Ctrl+F6 to exit CLI focus

Copy Paste

Top

Figura 38. Comando show spanning-tree DLS2 parte 4.

The screenshot shows a network device window titled 'DLS2' with tabs for 'Physical', 'Config', 'CLI', and 'Attributes'. The 'CLI' tab is active, displaying the 'IOS Command Line Interface' output for the 'show spanning-tree' command. The output is divided into two sections: VLAN0345 and VLAN0434. Each section shows the spanning tree protocol status, root and bridge IDs, and a table of interface roles and costs.

VLAN0345

```
Spanning tree enabled protocol ieee
Root ID    Priority    24921
           Address    00D0.D369.A99C
           Cost      18
           Port      28 (Port-channel2)
           Hello Time 2 sec  Max Age 20 sec  Forward Delay 15 sec

Bridge ID   Priority    29017 (priority 28672 sys-id-ext 345)
           Address    0001.439E.BC59
           Hello Time 2 sec  Max Age 20 sec  Forward Delay 15 sec
           Aging Time 20
```

Interface	Role	Sts	Cost	Prio.Nbr	Type
Fa0/7	Desg	FWD	19	128.7	P2p
Fa0/8	Desg	FWD	19	128.8	P2p
Fa0/9	Desg	FWD	19	128.9	P2p
Fa0/10	Desg	FWD	19	128.10	P2p
Po3	Altn	BLK	9	128.29	Shr
Po2	Root	FWD	9	128.28	Shr

VLAN0434

```
Spanning tree enabled protocol ieee
Root ID    Priority    25010
           Address    00D0.D369.A99C
           Cost      18
           Port      28 (Port-channel2)
           Hello Time 2 sec  Max Age 20 sec  Forward Delay 15 sec

Bridge ID   Priority    29106 (priority 28672 sys-id-ext 434)
           Address    0001.439E.BC59
           Hello Time 2 sec  Max Age 20 sec  Forward Delay 15 sec
           Aging Time 20
```

Interface	Role	Sts	Cost	Prio.Nbr	Type
Fa0/7	Desg	FWD	19	128.7	P2p
Fa0/8	Desg	FWD	19	128.8	P2p
Fa0/9	Desg	FWD	19	128.9	P2p
Fa0/10	Desg	FWD	19	128.10	P2p
Po3	Altn	BLK	9	128.29	Shr
Po2	Root	FWD	9	128.28	Shr

--More--

Ctrl+F6 to exit CLI focus

Copy Paste

Top

Figura 39. Comando show spanning-tree DLS2 parte 5.

The screenshot shows a network device CLI window titled 'DLS2'. The window has tabs for 'Physical', 'Config', 'CLI', and 'Attributes', with 'CLI' selected. The main content area displays the output of the 'show spanning-tree' command for two VLANs: VLAN0567 and VLAN0800.

VLAN0567

```
Spanning tree enabled protocol ieee
Root ID    Priority    33335
          Address    0001.439E.BC59
          This bridge is the root
          Hello Time 2 sec  Max Age 20 sec  Forward Delay 15 sec

Bridge ID  Priority    33335 (priority 32768 sys-id-ext 567)
          Address    0001.439E.BC59
          Hello Time 2 sec  Max Age 20 sec  Forward Delay 15 sec
          Aging Time 20
```

Interface	Role	Sts	Cost	Prio.Nbr	Type
Fa0/7	Desg	FWD	19	128.7	P2p
Fa0/8	Desg	FWD	19	128.8	P2p
Fa0/9	Desg	FWD	19	128.9	P2p
Fa0/10	Desg	FWD	19	128.10	P2p
Po3	Desg	FWD	9	128.29	Shr
Po2	Desg	FWD	9	128.28	Shr

VLAN0800

```
Spanning tree enabled protocol ieee
Root ID    Priority    25376
          Address    00D0.D369.A99C
          Cost        18
          Port        28 (Port-channel2)
          Hello Time 2 sec  Max Age 20 sec  Forward Delay 15 sec

Bridge ID  Priority    29472 (priority 28672 sys-id-ext 800)
          Address    0001.439E.BC59
          Hello Time 2 sec  Max Age 20 sec  Forward Delay 15 sec
          Aging Time 20
```

Interface	Role	Sts	Cost	Prio.Nbr	Type
Fa0/7	Desg	FWD	19	128.7	P2p
Fa0/8	Desg	FWD	19	128.8	P2p
Fa0/9	Desg	FWD	19	128.9	P2p
Fa0/10	Desg	FWD	19	128.10	P2p
Po3	Altn	BLK	9	128.29	Shr
Po2	Root	FWD	9	128.28	Shr

DLS2#
DLS2#

Ctrl+F6 to exit CLI focus

Copy Paste

Top

CONCLUSIONES

En el desarrollo del escenario 1 se puede observar en la parte 2 de verificación de red y control de trayectoria que el protocolo OSPFv3 fue programado de manera correcta y que tiene funcionalidad. Para el caso de EIGRP se observa que también fue programado de manera correcta usando EIGRP nombrado para el direccionamiento de doble pila. Además se observa que la redistribución en R2 tanto a nivel de IPv4 como IPv6 se hizo de manera correcta ya que se puede evidenciar en las tablas de enrutamiento las redes externas en los protocolos EIGRP y OSPF configurados en los routers R1 y R3 respectivamente. Por otro lado se comprueba que hay conectividad para el direccionamiento IPv6 e IPv4 a través del comando ping desde cada router a cada una de las direcciones de la red. De igual manera se puede observar a través del comando traceroute las rutas que toma cada router para llegar a cada una de las direcciones IP de la topología de la red.

Para el escenario 2, en la parte 2 se verifica la existencia de las VLAN correctamente en todos los Switches y la asignación de puertos troncales y de acceso de acuerdo a lo solicitado. Además, se puede verificar que el EtherChannel entre DLS1 y ALS1 está configurado correctamente, así como la configuración de Spanning tree entre DLS1 o DLS2 para cada VLAN. Los inconvenientes presentados en el desarrollo de este escenario se dieron porque los Switchs no reciben algunos comandos como son: VTP versión 3, comando vtp primary vlan, state suspend, switchport host. Además las Vlans que permite el switch son de 1 a 1005 ya que no cuenta con Vlans extendidas.

El escenario 1 fue desarrollado en el software GNS3 con Routers Cisco 7200. El desarrollo del escenario 2 se realizó en el software Packet Tracer. Los Switches de capa 2 fueron los Cisco 2960 y los de capa 3 fueron los Cisco 3560.

BIBLIOGRAFÍA

Teare, D., Vachon B., Graziani, R. (2015). CISCO Press (Ed). Basic Network and Routing Concepts. Implementing Cisco IP Routing (ROUTE) Foundation Learning Guide CCNP ROUTE 300-101. Recuperado de <https://1drv.ms/b/s!AmIJYei-NT1IlnMfy2rhPZHwEoWx>

Teare, D., Vachon B., Graziani, R. (2015). CISCO Press (Ed). EIGRP Implementation. Implementing Cisco IP Routing (ROUTE) Foundation Learning Guide CCNP ROUTE 300-101. Recuperado de <https://1drv.ms/b/s!AmIJYei-NT1IlnMfy2rhPZHwEoWx>

Teare, D., Vachon B., Graziani, R. (2015). CISCO Press (Ed). OSPF Implementation. Implementing Cisco IP Routing (ROUTE) Foundation Learning Guide CCNP ROUTE 300-101. Recuperado de <https://1drv.ms/b/s!AmIJYei-NT1IlnMfy2rhPZHwEoWx>

Teare, D., Vachon B., Graziani, R. (2015). CISCO Press (Ed). Manipulating Routing Updates. Implementing Cisco IP Routing (ROUTE) Foundation Learning Guide CCNP ROUTE 300-101. Recuperado de <https://1drv.ms/b/s!AmIJYei->

Froom, R., Frahim, E. (2015). CISCO Press (Ed). Spanning Tree Implementation. Implementing Cisco IP Switched Networks (SWITCH) Foundation Learning Guide CCNP SWITCH 300-115. Recuperado de <https://1drv.ms/b/s!AmIJYei-NT1IlnWR0hoMxgBNv1CJ>

Froom, R., Frahim, E. (2015). CISCO Press (Ed). InterVLAN Routing. Implementing Cisco IP Switched Networks (SWITCH) Foundation Learning Guide CCNP SWITCH 300-115. Recuperado de <https://1drv.ms/b/s!AmIJYei-NT1IlnWR0hoMxgBNv1CJ>

Froom, R., Frahim, E. (2015). CISCO Press (Ed). Fundamentals Review. Implementing Cisco IP Switched Networks (SWITCH) Foundation Learning Guide CCNP SWITCH 300-115. Recuperado de <https://1drv.ms/b/s!AmIJYei-NT1IlnWR0hoMxgBNv1CJ>