

DIPLOMADO DE PROFUNDIZACIÓN CISCO
PRUEBA DE HABILIDADES PRÁCTICAS CISCO CCNP

EDGARDO TOBON ZUÑIGA

UNIVERSIDAD NACIONAL ABIERTA Y A DISTANCIA - UNAD
ESCUELA DE CIENCIAS BÁSICAS, TECNOLOGÍA E INGENIERÍA - ECBTI
INGENIERÍA ELECTRÓNICA
BARRANCABERMEJA
2019

DIPLOMADO DE PROFUNDIZACIÓN CISCO
PRUEBA DE HABILIDADES PRÁCTICAS CISCO CCNP

EDGARDO TOBON ZUÑIGA

Diplomado de opción de grado presentado para optar el título
de INGENIERO ELECTRÓNICO

DIRECTOR:
MSc. GERARDO GRANADOS ACUÑA

UNIVERSIDAD NACIONAL ABIERTA Y A DISTANCIA - UNAD
ESCUELA DE CIENCIAS BÁSICAS, TECNOLOGÍA E INGENIERÍA - ECBTI
INGENIERÍA ELECTRÓNICA
BARRANCABERMEJA
2019

NOTA DE ACEPTACIÓN:

Presidente del Jurado

Jurado

Jurado

Barrancabermeja, 12 diciembre 2019

AGRADECIMIENTOS

Mis más sentidos agradecimientos al Dios todopoderoso por darme salud y vida durante todo este tiempo.

A todas aquellas personas que de una u otra forma hicieron parte del sueño de ser ingeniero electrónico y que esta por ser alcanzado, en especial a mi esposa e hija que con paciencia pudieron soportar la soledad en esas largas noches de estudio.

A todos los tutores y directores y compañeros de grupo de las diferentes asignaturas cursadas a lo largo de la carrera.

.

CONTENIDO

AGRADECIMIENTOS	4
LISTADO DE IMAGENES	6
LISTADO DE FIGURAS	7
LISTADO DE TABLAS	8
RESUMEN	9
ABSTRACT	10
INTRODUCCIÓN	11
DESARROLLO DEL TRABAJO	12
Escenario 1	12
Parte 1: Configuración del escenario propuesto	13
Parte 2: Verificar conectividad de red y control de la trayectoria	20
Escenario 2	29
Parte 1: Configurar la red de acuerdo con las especificaciones	30
Parte 2: conectividad de red de prueba y las opciones configuradas	49
CONCLUSIONES	50
BIBLIOGRAFÍA	51

LISTADO DE IMAGENES

Imagen 1 comando show ip route – R2.....	20
Imagen 2 Comando show ip route - R1.....	21
Imagen 3 comando show ip route - R3	23
Imagen 4 Comando ping - R1	25
Imagen 5 comando ping - R1	26

LISTADO DE FIGURAS

Figura 1 Escenario 1.....	12
Figura 2 Simulación escenario 1 - Dispositivos apagados	12
Figura 3 Simulación escenario 1 - Dispositivos encendidos	13
Figura 4 Escenario 2.....	29
Figura 5 Escenario 2 - Dispositivos encendidos.....	30
Figura 6 Escenario 2 Dispositivos apagados	30

LISTADO DE TABLAS

Tabla 1 VLAN a configurar	44
Tabla 2 interfaces como puertos de acceso.....	48

RESUMEN

Escenario 1: Una empresa de confecciones posee tres sucursales distribuidas en las ciudades de Bogotá, Medellín y Bucaramanga, en donde el estudiante será el administrador de la red, el cual deberá configurar e interconectar entre sí cada uno de los dispositivos que forman parte del escenario, acorde con los lineamientos establecidos para el direccionamiento IP, protocolos de enrutamiento y demás aspectos que forman parte de la topología de red.

Escenario 2: Una empresa de comunicaciones presenta una estructura Core acorde a la topología de red, en donde el estudiante será el administrador de la red, el cual deberá configurar e interconectar entre sí cada uno de los dispositivos que forman parte del escenario, acorde con los lineamientos establecidos para el direccionamiento IP, ether-channels, VLAN's y demás aspectos que forman parte del escenario propuesto.

Palabras clave: Direccionamiento IP, topologia de red, Vlan's, protocolos de enrutamiento, Etherchannel.

ABSTRACT

Scenario 1: A clothing company has trece branches distributed in the cities of Bogotá, Medellín and Bucaramanga, where the student will be the network administrator, who must configure and interconnect each of the devices that are part of the scenario, in accordance with the guidelines established for IP addressing, hosting protocols and other aspects that are part of the network topology.

Scenario 2: A communications company presents a Core structure according to the network topology, where the student will be the network administrator, who must configure and interconnect each of the devices that are part of the scenario, according to the guidelines established for IP addressing, ether-channels, VLANs and other aspects that are part of the proposed scenario.

Keywords: IP addressing, network topology, Vlan's, routing protocols, Etherchannel.

INTRODUCCIÓN

El presente documento tiene como fin demostrar los conocimientos y habilidades adquiridos a lo largo de las diversas prácticas y laboratorios virtuales presentados en el diplomado de profundización en redes Cisco Networking, el cual es requisito para la obtención del título de pregrado en ingeniería electrónica en la Universidad Nacional Abierta y a distancia UNAD.

El software de simulación utilizado para trabajar en los dos escenarios con sus respectivas topologías de redes con diferentes exigencias de conexión y condiciones de implementación, fue el packet tracer, el cual está diseñado para el trabajo de redes con router's y switches de la tecnología Cisco.

DESARROLLO DEL TRABAJO

Escenario 1

Una empresa de confecciones posee tres sucursales distribuidas en las ciudades de Bogotá, Medellín y Bucaramanga, en donde el estudiante será el administrador de la red, el cual deberá configurar e interconectar entre sí cada uno de los dispositivos que forman parte del escenario, acorde con los lineamientos establecidos para el direccionamiento IP, protocolos de enrutamiento y demás aspectos que forman parte de la topología de red.

Topología de red



FIGURA 1 ESCENARIO 1



FIGURA 2 SIMULACIÓN ESCENARIO 1 - DISPOSITIVOS APAGADOS

Configurar la topología de red, de acuerdo con las siguientes especificaciones.

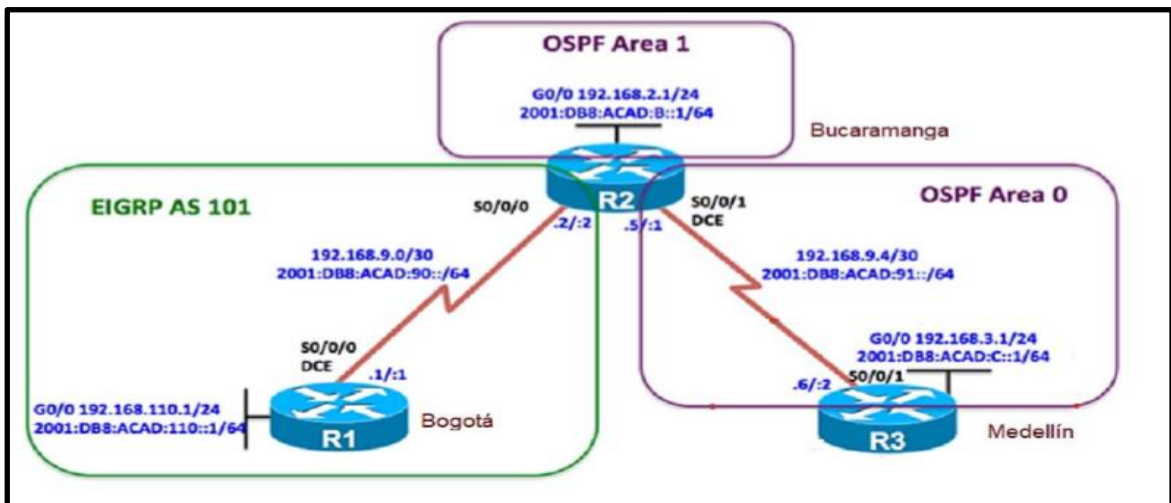

FIGURA 3 SIMULACIÓN ESCENARIO 1 - DISPOSITIVOS ENCENDIDOS

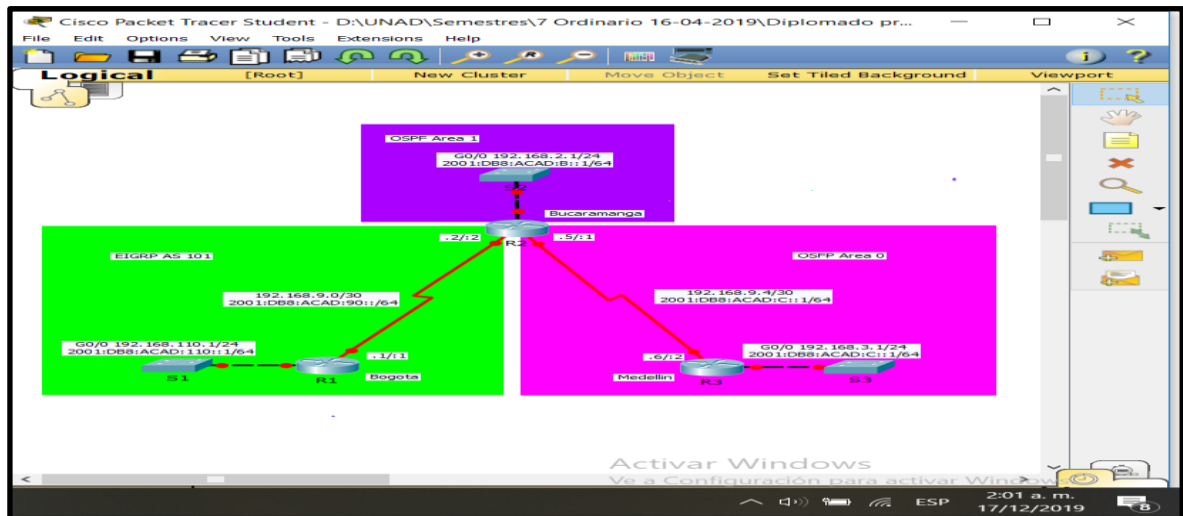
Parte 1: Configuración del escenario propuesto.

1. Configurar las interfaces con las direcciones IPv4 e IPv6 que se muestran en la topología de red.

Bogotá-R1

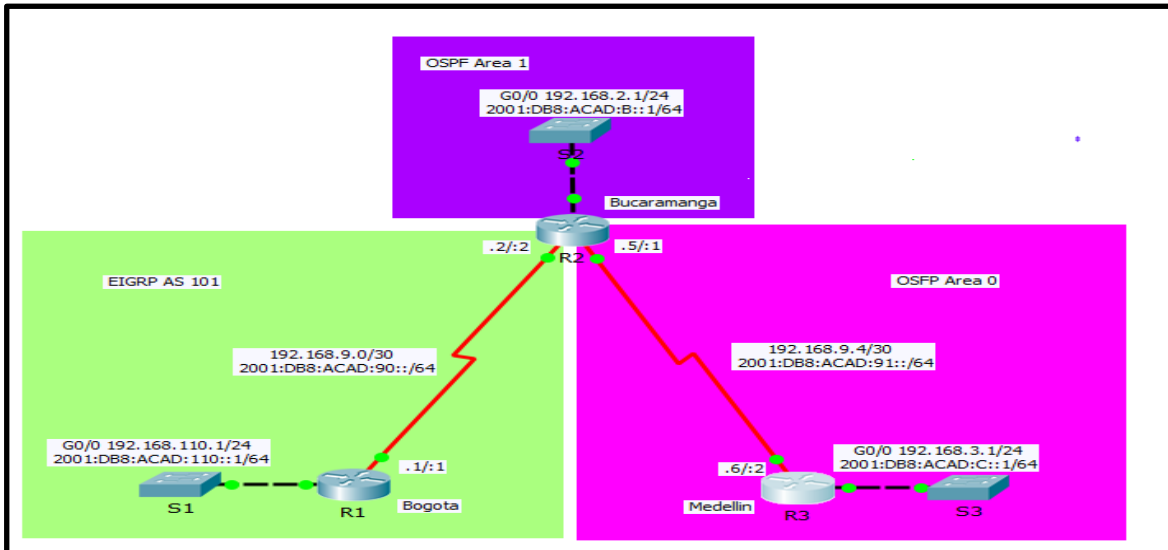
```

Router>enable
Router#config t
Enter configuration commands, one per line. End with CNTL/Z.
Router(config)#hostname Bogota
Bogota(config)#ipv6 unicast-routing
Bogota(config)#line con 0
Bogota(config-line)#logging synchronous
Bogota(config-line)#exec-timeout 0 0Bogota(config-line)#exit
Bogota(config)#int g0/0
Bogota(config-if)#ip address 192.168.110.1 255.255.255.0
Bogota(config-if)#ipv6 address 2001:DB8:ACAD:110::1/64
Bogota(config-if)#no shutdown
Bogota(config-if) #
%LINK-5-CHANGED: Interface GigabitEthernet0/0, changed state to up
%LINEPROTO-5-UPDOWN: Line protocol on Interface GigabitEthernet0/0,
changed state to up
Bogota(config-if)#exit
    
```

```
Bogota(config)#int s0/0/0
Bogota(config-if)#ip address 192.168.9.1 255.255.255.252
Bogota(config-if)#ipv6 address 2001:DB8:ACAD:90::1/64
Bogota(config-if)#ipv6 address fe80::1 link-local
Bogota(config-if)#no shutdown
Bogota(config-if)#
%LINK-5-CHANGED: Interface Serial0/0/0, changed state to up
Bogota(config-if)#
%LINEPROTO-5-UPDOWN: Line protocol on Interface Serial0/0/0, changed state
to up
Bogota(config-if)#clock rate 128000
Bogota(config-if)#exit
Bogota(config)#
```

Bucaramanga-R2

```
Router>enable
Router#config t
Enter configuration commands, one per line. End with CNTL/Z.
Router(config)#hostname Bucaramanga
Bucaramanga(config)#ipv6 unicast-routing
Bucaramanga(config)#no ip domain-lookup
Bucaramanga(config)#line console 0
Bucaramanga(config-line)#logging synchronous
Bucaramanga(config-line)#exec-timeout 0 0
Bucaramanga(config-line)#exit
Bucaramanga(config)#int s0/0/0
Bucaramanga(config-if)#ip address 192.168.9.2 255.255.255.252
Bucaramanga(config-if)#ipv6 address 2001:db8:acad:90::2/64
Bucaramanga(config-if)#ipv6 address fe80::2 link-local
Bucaramanga(config-if)#no shutdown
%LINK-5-CHANGED: Interface Serial0/0/0, changed state to down
Bucaramanga(config-if)#exit
Bucaramanga(config)#int s
%LINK-5-CHANGED: Interface Serial0/0/0, changed state to up
%LINEPROTO-5-UPDOWN: Line protocol on Interface Serial0/0/0, changed state
to up
Bucaramanga(config)#int s0/0/1
Bucaramanga(config-if)#ip address 192.168.9.5 255.255.255.252
Bucaramanga(config-if)#ipv6 address 2001:db8:acad:91::1/64
Bucaramanga(config-if)#ipv6 address fe80::2 link-local
Bucaramanga(config-if)#clock rate 128000
Bucaramanga(config-if)#no shutdown
%LINK-5-CHANGED: Interface Serial0/0/1, changed state to down
Bucaramanga(config-if)#exit
```

```
Bucaramanga(config)#int g0/0
Bucaramanga(config-if)#ip address 192.168.2.1 255.255.255.0
Bucaramanga(config-if)#ipv6 address 2001:db8:acad:b::1/64
Bucaramanga(config-if)#no shutdown
Bucaramanga(config-if)#
%LINK-5-CHANGED: Interface GigabitEthernet0/0, changed state to up
%LINEPROTO-5-UPDOWN: Line protocol on Interface GigabitEthernet0/0,
changed state to up
Bucaramanga(config-if)#
```

Medellin-R3

```
Router>enable
Router#config t
Enter configuration commands, one per line. End with CNTL/Z.
Router(config)#hostname Medellin
Medellin(config)#ipv6 unicast-routing
Medellin(config)#no ip domain-lookup
Medellin(config)#line console 0
Medellin(config-line)#logging synchronous
Medellin(config-line)#exec-timeout 0 0
Medellin(config-line)#exit
Medellin(config)#int s0/0/1
Medellin(config-if)#ip address 192.168.9.6 255.255.255.252
Medellin(config-if)#ipv6 address 2001:db8:acad:91::2/64
Medellin(config-if)#ipv6 address fe80::3 link-local
Medellin(config-if)#no shutdown
Medellin(config-if)#
%LINK-5-CHANGED: Interface Serial0/0/1, changed state to up
Medellin(config-if)#exit
%LINEPROTO-5-UPDOWN: Line protocol on Interface Serial0/0/1, changed state
to up
Medellin(config-if)#exit
Medellin(config)#int g0/0
Medellin(config-if)#ip address 192.168.3.1 255.255.255.0
Medellin(config-if)#ipv6 address 2001:db8:acad:c::1/64
Medellin(config-if)#no shutdown
Medellin(config-if)#
%LINK-5-CHANGED: Interface GigabitEthernet0/0, changed state to up
%LINEPROTO-5-UPDOWN: Line protocol on Interface GigabitEthernet0/0,
changed state to up
Medellin(config-if)#
```

2. Ajustar el ancho de banda a 128 kbps sobre cada uno de los enlaces seriales ubicados en R1, R2, y R3 y ajustar la velocidad de reloj de las conexiones de DCE según sea apropiado.

Bogotá- R1

```
Bogotá(config)#interface s0/0/0
Bogota(config-if)#bandwidth 128
Bogota(config-if)#clock rate 128000
Bogota(config-if)#no shutdown
Bogota(config-if)#
```

Bucaramanga-R2

```
Bucaramanga(config-if)#iexit
Bucaramanga (config)#interface s0/0/0
Bucaramanga (config-if)#bandwidth 128
Bucaramanga (config-if)#no shutdown
Bucaramanga(config-if)#iexit
Bucaramanga (config)#interface s0/0/1
Bucaramanga (config-if)#bandwidth 128
Bucaramanga (config-if)#clock rate 128000
Bucaramanga (config-if)#no shutdown
Bucaramanga (config-if)#
```

Medellin-R3

```
Medellin(config)#interface s0/0/1
Medellin(config-if)#bandwidth 128
Medellin(config-if)#no shutdown
Medellin(config-if)#
```

3. En R2 y R3 configurar las familias de direcciones OSPFv3 para IPv4 e IPv6. Utilice el identificador de enrutamiento 2.2.2.2 en R2 y 3.3.3.3 en R3 para ambas familias de direcciones.

Bucaramanga-R2

```
Bucaramanga(config-router)#router-id 2.2.2.2
Bucaramanga(config-router)#exit
Bucaramanga(config)#ipv6 router ospf 1
Bucaramanga(config-rtr)#router-id 2.2.2.2
Bucaramanga(config-rtr)#
%LINEPROTO-5-UPDOWN: Line protocol on Interface Serial0/0/0, changed state to down
```

```
%LINEPROTO-5-UPDOWN: Line protocol on Interface Serial0/0/1, changed state to down
%LINEPROTO-5-UPDOWN: Line protocol on Interface Serial0/0/1, changed state to up
%LINEPROTO-5-UPDOWN: Line protocol on Interface Serial0/0/0, changed state to up
```

Medellin-R3

```
Medellin(config)#route ospf 1
Medellin(config-router)#router-id 3.3.3.3
Medellin(config-router)#passive-interface g0/0
Medellin(config-router)#default-information originate ?
<cr>
Medellin(config-router)#default-information originate
Medellin(config-router)#ipv6 router ospf 1
Medellin(config-rtr)#router-id 3.3.3.3
Medellin(config-rtr)#passive-interface g0/0
Medellin(config-rtr)#exit
Medellin(config)#
```

4. En R2 configurar la interfaz g0/0 en el área 1 se OSPF y la conexión serial entre R2 y R3 en OSPF área 0.

Bucaramanga-R2

```
Bucaramanga(config)#int g0/0
Bucaramanga(config-if)#ospfv3 1 ipv4 area 0
^
% Invalid input detected at '^' marker.

Bucaramanga(config-if)#ospfv3 1 ipv6 area 0
^
% Invalid input detected at '^' marker.
Bucaramanga(config-if)#exit
Bucaramanga(config)#
```

5. En R3, configurar la interfaz g0/0 y la conexión serial entre R2 y R3 en OSPF área 0.

```
Medellin(config)#int g0/0
Medellin(config-if)#ospf 1 ipv4 area 1
^
% Invalid input detected at '^' marker.
Medellin(config-if)#ospf 1 ipv6 area 1
```

```

      ^
% Invalid input detected at '^' marker.
Medellin(config-if)#exit
Medellin(config)#
Medellin(config)#int s0/0/1
Medellin(config-if)#ospf 1 ipv4 area 0
      ^
% Invalid input detected at '^' marker.
Medellin(config-if)#ospf 1 ipv6 area 0
      ^
% Invalid input detected at '^' marker.
Medellin(config-if)#exit

```

- Configurar el área 1 como un área totalmente Stubby.

Bucaramanga-R2

```

Bucaramanga(config)#router ospf 1
Bucaramanga(config-router)#area 1 stub no-summary
Bucaramanga(config-router)#exit
Bucaramanga(config)#ipv6 router ospf 1
Bucaramanga(config-rtr)#area 1 stub no-summary
Bucaramanga(config-rtr)#exit
Bucaramanga(config)#

```

- Propagar rutas por defecto de IPv4 y IPv6 en R3 al interior del dominio OSPFv3.
Nota: Es importante tener en cuenta que una ruta por defecto es diferente a la definición de rutas estáticas.

Medellin-R3

```

Medellin(config)#route ospf 1
Medellin(config-router)#default-information originate
Medellin(config-router)#exit
Medellin(config)#ipv6 router ospf 1
Medellin(config-rtr)#default-information originate
Medellin(config-rtr)#exit

```

- Realizar la configuración del protocolo EIGRP para IPv4 como IPv6. Configurar la interfaz F0/0 de R1 y la conexión entre R1 y R2 para EIGRP con el sistema autónomo 101. Asegúrese de que el resumen automático está desactivado.

Bogota-R1

```
Bogota(config)#router eigrp 101
Bogota(config-router)#network 192.168.9.0 0.0.0.3
Bogota(config-router)#network 192.168.100.0 0.0.0.255
Bogota(config-router)#ipv6 router eigrp 101
Bogota(config-rtr)#eigrp router-id 1.1.1.1
Bogota(config-rtr)#exit
Bogota(config)#
```

9. Configurar las interfaces pasivas para EIGRP según sea apropiado.

Bogota-R1

```
Bogota(config)#int g0/0
Bogota(config-if)#passive-interface
      ^
% Invalid input detected at '^' marker.
Bogota(config-if)#
```

10. En R2, configurar la redistribución mutua entre OSPF y EIGRP para IPv4 e IPv6.
Asignar métricas apropiadas cuando sea necesario.

Bucaramanga-R2

```
Bucaramanga(config)#router eigrp 101
Bucaramanga(config-router)#redistribute ospf 1 metric 1500 100 255 1 15000
Bucaramanga(config-router)#exit
Bucaramanga(config)#ipv6 router eigrp 101
Bucaramanga(config-rtr)#redistribute ospf 1 metric 1500 100 255 1 15000
Bucaramanga(config-rtr)#exit
Bucaramanga(config)#
```

11. En R2, de hacer publicidad de la tuta 192.168.3.0/24 a R1 mediante una lista de distribución y ACL.

Bogota

```
Bogota(config)#ip access-list standard Medellin-to-bogota
Bogota(config-std-nacl)#remark ACL to filter 192.168.3.0/24
Bogota(config-std-nacl)#deny 192.168.3.0 0.0.0.255
Bogota(config-std-nacl)#permit any
Bogota(config-std-nacl)#
```

Parte 2: Verificar conectividad de red y control de la trayectoria.

- a. Registrar las tablas de enrutamiento en cada uno de los routers, acorde con los parámetros de configuración establecidos en el escenario propuesto.

Bucaramanga-R2

```
Bucaramanga#show ip route
Codes: L - local, C - connected, S - static, R - RIP, M - mobile, B - BGP
       D - EIGRP, EX - EIGRP external, O - OSPF, IA - OSPF inter area
       N1 - OSPF NSSA external type 1, N2 - OSPF NSSA external type 2
       E1 - OSPF external type 1, E2 - OSPF external type 2, E - EGP
       I - IS-IS, L1 - IS-IS level-1, L2 - IS-IS level-2, ia - IS-IS inter area
       * - candidate default, U - per-user static route, o - ODR
       P - periodic downloaded static route

Gateway of last resort is not set

192.168.2.0/24 is variably subnetted, 2 subnets, 2 masks
C 192.168.2.0/24 is directly connected, GigabitEthernet0/0
L 192.168.2.1/32 is directly connected, GigabitEthernet0/0
192.168.9.0/24 is variably subnetted, 4 subnets, 2 masks
C 192.168.9.0/30 is directly connected, Serial0/0/0
L 192.168.9.2/32 is directly connected, Serial0/0/0
C 192.168.9.4/30 is directly connected, Serial0/0/1
L 192.168.9.5/32 is directly connected, Serial0/0/1
Bucaramanga#show ip protocols
Routing Protocol is "eigrp 101"
  Outgoing update filter list for all interfaces is not set
  Incoming update filter list for all interfaces is not set
  Default networks flagged in outgoing updates
  Default networks accepted from incoming updates
  EIGRP metric weight K1=1, K2=0, K3=1, K4=0, K5=0
  EIGRP maximum hopcount 100
  EIGRP maximum metric variance 1
  Redistributing: eigrp 101, ospf 1
  Automatic network summarization is in effect
  Automatic address summarization:
  Maximum path: 4
  Routing for Networks:
  Routing Information Sources:
    Gateway         Distance         Last Update
  Distance: internal 90 external 170

Routing Protocol is "ospf 1"
  Outgoing update filter list for all interfaces is not set
  Incoming update filter list for all interfaces is not set
  Router ID 2.2.2.2
  Number of areas in this router is 1. 0 normal 1 stub 0 nssa
  Routing for Networks:
  Routing Information Sources:
    Gateway         Distance         Last Update
  Distance: (default is 110)
Bucaramanga#
```

IMAGEN 1 COMANDO SHOW IP ROUTE – R2

Bucaramanga#show ip route

Codes: L - local, C - connected, S - static, R - RIP, M - mobile, B - BGP

D - EIGRP, EX - EIGRP external, O - OSPF, IA - OSPF inter area

N1 - OSPF NSSA external type 1, N2 - OSPF NSSA external type 2

E1 - OSPF external type 1, E2 - OSPF external type 2, E - EGP

i - IS-IS, L1 - IS-IS level-1, L2 - IS-IS level-2, ia - IS-IS inter area

* - candidate default, U - per-user static route, o - ODR

P - periodic downloaded static route

Gateway of last resort is not set

192.168.2.0/24 is variably subnetted, 2 subnets, 2 masks

C 192.168.2.0/24 is directly connected, GigabitEthernet0/0

L 192.168.2.1/32 is directly connected, GigabitEthernet0/0

192.168.9.0/24 is variably subnetted, 4 subnets, 2 masks

C 192.168.9.0/30 is directly connected, Serial0/0/0

L 192.168.9.2/32 is directly connected, Serial0/0/0

C 192.168.9.4/30 is directly connected, Serial0/0/1

L 192.168.9.5/32 is directly connected, Serial0/0/1

Bucaramanga#show ip protocols

Routing Protocol is "eigrp 101 "

Outgoing update filter list for all interfaces is not set
 Incoming update filter list for all interfaces is not set
 Default networks flagged in outgoing updates
 Default networks accepted from incoming updates
 EIGRP metric weight K1=1, K2=0, K3=1, K4=0, K5=0
 EIGRP maximum hopcount 100
 EIGRP maximum metric variance 1
 Redistributing: eigrp 101, ospf 1
 Automatic network summarization is in effect
 Automatic address summarization:
 Maximum path: 4
 Routing for Networks:
 Routing Information Sources:
 Gateway Distance Last Update
 Distance: internal 90 external 170

Routing Protocol is "ospf 1"
 Outgoing update filter list for all interfaces is not set
 Incoming update filter list for all interfaces is not set
 Router ID 2.2.2.2
 Number of areas in this router is 1. 0 normal 1 stub 0 nssa
 Maximum path: 4
 Routing for Networks:
 Routing Information Sources:
 Gateway Distance Last Update
 Distance: (default is 110)

Bogota-R1

```

Bogota#show ip route
Codes: L - local, C - connected, S - static, R - RIP, M - mobile, B -
BGP
       D - EIGRP, EX - EIGRP external, O - OSPF, IA - OSPF inter area
       N1 - OSPF NSSA external type 1, N2 - OSPF NSSA external type 2
       E1 - OSPF external type 1, E2 - OSPF external type 2, E - EGP
       I - IS-IS, L1 - IS-IS level-1, L2 - IS-IS level-2, Ia - IS-IS
inter area
       * - candidate default, U - per-user static route, o - ODR
       P - periodic downloaded static route
Gateway of last resort is not set

  192.168.9.0/24 is variably subnetted, 3 subnets, 3 masks
D       192.168.9.0/24 is a summary, 01:21:34, Null0
C       192.168.9.0/30 is directly connected, Serial0/0/0
L       192.168.9.1/32 is directly connected, Serial0/0/0
C       192.168.110.0/24 is variably subnetted, 2 subnets, 2 masks
C       192.168.110.0/24 is directly connected, GigabitEthernet0/0
L       192.168.110.1/32 is directly connected, GigabitEthernet0/0
Bogota#show ip protocols
Routing Protocol is "eigrp 101"
  Outgoing update filter list for all interfaces is not set
  Incoming update filter list for all interfaces is not set
  Default networks flagged in outgoing updates
  Default networks accepted from incoming updates
  EIGRP metric weight K1=1, K2=0, K3=1, K4=0, K5=0
  EIGRP maximum hopcount 100
  EIGRP maximum metric variance 1
  Redistributing: eigrp 101
  Automatic network summarization is in effect
  Automatic address summarization:
    192.168.9.0/24 for GigabitEthernet0/0
    Summarizing with metric 20512000
  Maximum path: 4
  Routing for Networks:
    192.168.9.0/30
    192.168.110.0
    192.168.100.0
  Routing Information Sources:
    Gateway         Distance      Last Update
  Distance: internal 90 external 170
Bogota#
  
```

IMAGEN 2 COMANDO SHOW IP ROUTE - R1

Bogota#show ip route

Codes: L - local, C - connected, S - static, R - RIP, M - mobile, B - BGP
D - EIGRP, EX - EIGRP external, O - OSPF, IA - OSPF inter area
N1 - OSPF NSSA external type 1, N2 - OSPF NSSA external type 2
E1 - OSPF external type 1, E2 - OSPF external type 2, E - EGP
i - IS-IS, L1 - IS-IS level-1, L2 - IS-IS level-2, ia - IS-IS inter area
* - candidate default, U - per-user static route, o - ODR
P - periodic downloaded static route

Gateway of last resort is not set

192.168.9.0/24 is variably subnetted, 3 subnets, 3 masks
D 192.168.9.0/24 is a summary, 01:21:34, Null0
C 192.168.9.0/30 is directly connected, Serial0/0/0
L 192.168.9.1/32 is directly connected, Serial0/0/0
192.168.110.0/24 is variably subnetted, 2 subnets, 2 masks
C 192.168.110.0/24 is directly connected, GigabitEthernet0/0
L 192.168.110.1/32 is directly connected, GigabitEthernet0/0
Bogota#show ip protocols

Routing Protocol is "eigrp 101 "

Outgoing update filter list for all interfaces is not set
Incoming update filter list for all interfaces is not set
Default networks flagged in outgoing updates
Default networks accepted from incoming updates
EIGRP metric weight K1=1, K2=0, K3=1, K4=0, K5=0
EIGRP maximum hopcount 100
EIGRP maximum metric variance 1

Redistributing: eigrp 101

Automatic network summarization is in effect

Automatic address summarization:

192.168.9.0/24 for GigabitEthernet0/0

Summarizing with metric 20512000

Maximum path: 4

Routing for Networks:

192.168.9.0/30

192.168.110.0

192.168.100.0

Routing Information Sources:

Gateway Distance Last Update

Distance: internal 90 external 170

Bogota#

Medellin-R3

```
Medellin#show ip route
Codes: L - local, C - connected, S - static, R - RIP, M - mobile, B - BGP
       D - EIGRP, EX - EIGRP external, O - OSPF, IA - OSPF inter area
       N1 - OSPF NSSA external type 1, N2 - OSPF NSSA external type 2
       E1 - OSPF external type 1, E2 - OSPF external type 2, E - EGP
       i - IS-IS, L1 - IS-IS level-1, L2 - IS-IS level-2, ia - IS-IS inter area
       * - candidate default, U - per-user static route, o - ODR
       P - periodic downloaded static route

Gateway of last resort is not set

C     192.168.3.0/24 is variably subnetted, 2 subnets, 2 masks
L     192.168.3.1/32 is directly connected, GigabitEthernet0/0
C     192.168.9.0/24 is variably subnetted, 2 subnets, 2 masks
L     192.168.9.4/30 is directly connected, Serial0/0/1
L     192.168.9.6/32 is directly connected, Serial0/0/1
Medellin#show ip protocols

Routing Protocol is "eigrp 1"
  Outgoing update filter list for all interfaces is not set
  Incoming update filter list for all interfaces is not set
  Default networks flagged in outgoing updates
  Default networks accepted from incoming updates
  EIGRP metric weight K1=1, K2=0, K3=1, K4=0, K5=0
  EIGRP maximum hopcount 100
  EIGRP maximum metric variance 1
  Redistributing: eigrp 1
    Automatic network summarization is in effect
    Maximum path: 4
  Routing for Networks:
    Gateway of last resort is not set
  Routing Information Sources:
    Distance: internal 90 external 170

Routing Protocol is "eigrp 101"
  Outgoing update filter list for all interfaces is not set
  Incoming update filter list for all interfaces is not set
  Default networks flagged in outgoing updates
  Default networks accepted from incoming updates
  EIGRP metric weight K1=1, K2=0, K3=1, K4=0, K5=0
  EIGRP maximum hopcount 100
  EIGRP maximum metric variance 1
  Redistributing: eigrp 101
    Automatic network summarization is in effect
    Maximum path: 4
  Routing for Networks:
    192.168.9.0/30
    192.168.110.0
  Routing Information Sources:
    Gateway of last resort is not set
  Distance: internal 90 external 170

Routing Protocol is "ospf 1"
  Outgoing update filter list for all interfaces is not set
  Incoming update filter list for all interfaces is not set
  Router ID 3.3.3.3
  Number of areas in this router is 0. 0 normal 0 stub 0 nssa
  Maximum path: 4
  Routing for Networks:
  Passive Interface(s):
    GigabitEthernet0/0
  Routing Information Sources:
    Gateway of last resort is not set
  Distance: (default is 110)
```

IMAGEN 3 COMANDO SHOW IP ROUTE - R3

Medellin#show ip route

Codes: L - local, C - connected, S - static, R - RIP, M - mobile, B - BGP
D - EIGRP, EX - EIGRP external, O - OSPF, IA - OSPF inter area
N1 - OSPF NSSA external type 1, N2 - OSPF NSSA external type 2
E1 - OSPF external type 1, E2 - OSPF external type 2, E - EGP
i - IS-IS, L1 - IS-IS level-1, L2 - IS-IS level-2, ia - IS-IS inter area
* - candidate default, U - per-user static route, o - ODR
P - periodic downloaded static route

Gateway of last resort is not set

```
192.168.3.0/24 is variably subnetted, 2 subnets, 2 masks
C 192.168.3.0/24 is directly connected, GigabitEthernet0/0
L 192.168.3.1/32 is directly connected, GigabitEthernet0/0
192.168.9.0/24 is variably subnetted, 2 subnets, 2 masks
C 192.168.9.4/30 is directly connected, Serial0/0/1
L 192.168.9.6/32 is directly connected, Serial0/0/1
```

Medellin#show ip protocols

Routing Protocol is "eigrp 1 "

Outgoing update filter list for all interfaces is not set
Incoming update filter list for all interfaces is not set
Default networks flagged in outgoing updates
Default networks accepted from incoming updates
EIGRP metric weight K1=1, K2=0, K3=1, K4=0, K5=0
EIGRP maximum hopcount 100
EIGRP maximum metric variance 1

Redistributing: eigrp 1

Automatic network summarization is in effect
Automatic address summarization:
Maximum path: 4
Routing for Networks:
Routing Information Sources:
Gateway Distance Last Update
Distance: internal 90 external 170

Routing Protocol is "eigrp 101 "

Outgoing update filter list for all interfaces is not set
Incoming update filter list for all interfaces is not set
Default networks flagged in outgoing updates
Default networks accepted from incoming updates
EIGRP metric weight K1=1, K2=0, K3=1, K4=0, K5=0
EIGRP maximum hopcount 100
EIGRP maximum metric variance 1

Redistributing: eigrp 101

Automatic network summarization is in effect
Automatic address summarization:
Maximum path: 4
Routing for Networks:
192.168.9.0/30
192.168.110.0
Routing Information Sources:
Gateway Distance Last Update
Distance: internal 90 external 170

Routing Protocol is "ospf 1"

Outgoing update filter list for all interfaces is not set
Incoming update filter list for all interfaces is not set
Router ID 3.3.3.3
Number of areas in this router is 0. 0 normal 0 stub 0 nssa
Maximum path: 4
Routing for Networks:
Passive Interface(s):

GigabitEthernet0/0
Routing Information Sources:
Gateway Distance Last Update
Distance: (default is 110)

b. Verificar comunicación entre routers mediante el comando ping y traceroute

Bogota-R1

```
Bogota#ping 192.168.110.1
Type escape sequence to abort.
Sending 5, 100-byte ICMP Echos to 192.168.110.1, timeout is 2 seconds:
!!!!!!
Success rate is 100 percent (5/5), round-trip min/avg/max = 2/22/59 ms

Bogota#ping 192.168.9.1
Type escape sequence to abort.
Sending 5, 100-byte ICMP Echos to 192.168.9.1, timeout is 2 seconds:
!!!!!!
Success rate is 100 percent (5/5), round-trip min/avg/max = 2/7/13 ms

Bogota#ping 192.168.9.2
Type escape sequence to abort.
Sending 5, 100-byte ICMP Echos to 192.168.9.2, timeout is 2 seconds:
!!!!!!
Success rate is 100 percent (5/5), round-trip min/avg/max = 5/6/9 ms

Bogota#ping 192.168.2.1
Type escape sequence to abort.
Sending 5, 100-byte ICMP Echos to 192.168.2.1, timeout is 2 seconds:
.....
Success rate is 0 percent (0/5)

Bogota#ping 192.168.9.5
Type escape sequence to abort.
Sending 5, 100-byte ICMP Echos to 192.168.9.5, timeout is 2 seconds:
.....
Success rate is 0 percent (0/5)

Bogota#ping 192.168.9.6
Type escape sequence to abort.
Sending 5, 100-byte ICMP Echos to 192.168.9.6, timeout is 2 seconds:
.....
Success rate is 0 percent (0/5)

Bogota#ping 192.168.3.1
Type escape sequence to abort.
Sending 5, 100-byte ICMP Echos to 192.168.3.1, timeout is 2 seconds:
.....
Success rate is 0 percent (0/5)

Bogota#ping 192.168.1.1
Type escape sequence to abort.
Sending 5, 100-byte ICMP Echos to 192.168.1.1, timeout is 2 seconds:
.....
Success rate is 0 percent (0/5)
```

IMAGEN 4 COMANDO PING - R1

```

Bogota#ping 172.16.1.2
Type escape sequence to abort.
Sending 5, 100-byte ICMP Echos to 172.16.1.2, timeout is 2 seconds:
.....
Success rate is 0 percent (0/5)

Bogota#
%LINEPROTO-5-UPDOWN: Line protocol on Interface Serial0/0/0, changed state to down
%LINEPROTO-5-UPDOWN: Line protocol on Interface Serial0/0/0, changed state to up
Bogota#ping 2001:db8:acad:110::1
Type escape sequence to abort.
Sending 5, 100-byte ICMP Echos to 2001:db8:acad:110::1, timeout is 2 seconds:
!!!!!!
Success rate is 100 percent (5/5), round-trip min/avg/max = 3/7/21 ms

Bogota#ping 2001:db8:acad:90::1
Type escape sequence to abort.
Sending 5, 100-byte ICMP Echos to 2001:db8:acad:90::1, timeout is 2 seconds:
!!!!!!
Success rate is 100 percent (5/5), round-trip min/avg/max = 5/9/11 ms

Bogota#ping 2001:db8:acad:90::2
Type escape sequence to abort.
Sending 5, 100-byte ICMP Echos to 2001:db8:acad:90::2, timeout is 2 seconds:
!!!!!!
Success rate is 100 percent (5/5), round-trip min/avg/max = 1/9/21 ms

Bogota#ping 2001:db8:acad:91::1
Type escape sequence to abort.
Sending 5, 100-byte ICMP Echos to 2001:db8:acad:91::1, timeout is 2 seconds:
.....
Success rate is 0 percent (0/5)

Bogota#ping 2001:db8:acad:c::1
Type escape sequence to abort.
Sending 5, 100-byte ICMP Echos to 2001:db8:acad:c::1, timeout is 2 seconds:
.....
Success rate is 0 percent (0/5)

Bogota#ping 2001:db8:feed:1::1
Type escape sequence to abort.
Sending 5, 100-byte ICMP Echos to 2001:db8:feed:1::1, timeout is 2 seconds:
.....
Success rate is 0 percent (0/5)

Bogota#

```

IMAGEN 5 COMANDO PING - R1

Bogota#ping 192.168.110.1

```

Type escape sequence to abort.
Sending 5, 100-byte ICMP Echos to 192.168.110.1, timeout is 2 seconds:
!!!!!!
Success rate is 100 percent (5/5), round-trip min/avg/max = 2/22/59 ms

```

Bogota#ping 192.168.9.1

```

Type escape sequence to abort.
Sending 5, 100-byte ICMP Echos to 192.168.9.1, timeout is 2 seconds:

```

!!!!

Success rate is 100 percent (5/5), round-trip min/avg/max = 2/7/13 ms

Bogota#ping 192.168.9.2

Type escape sequence to abort.

Sending 5, 100-byte ICMP Echos to 192.168.9.2, timeout is 2 seconds:

!!!!

Success rate is 100 percent (5/5), round-trip min/avg/max = 5/6/9 ms

Bogota#ping 192.168.2.1

Type escape sequence to abort.

Sending 5, 100-byte ICMP Echos to 192.168.2.1, timeout is 2 seconds:

.....

Success rate is 0 percent (0/5)

Bogota#ping 192.168.9.5

Type escape sequence to abort.

Sending 5, 100-byte ICMP Echos to 192.168.9.5, timeout is 2 seconds:

.....

Success rate is 0 percent (0/5)

Bogota#ping 192.168.9.6

Type escape sequence to abort.

Sending 5, 100-byte ICMP Echos to 192.168.9.6, timeout is 2 seconds:

.....

Success rate is 0 percent (0/5)

Bogota#ping 192.168.3.1

Type escape sequence to abort.

Sending 5, 100-byte ICMP Echos to 192.168.3.1, timeout is 2 seconds:

.....

Success rate is 0 percent (0/5)

Bogota#ping 192.168.1.1

Type escape sequence to abort.

Sending 5, 100-byte ICMP Echos to 192.168.1.1, timeout is 2 seconds:

.....

Success rate is 0 percent (0/5)

Bogota#ping 172.16.1.2

Type escape sequence to abort.

Sending 5, 100-byte ICMP Echos to 172.16.1.2, timeout is 2 seconds:

.....

Success rate is 0 percent (0/5)

Bogota#

%LINEPROTO-5-UPDOWN: Line protocol on Interface Serial0/0/0, changed state to down

%LINEPROTO-5-UPDOWN: Line protocol on Interface Serial0/0/0, changed state to up

Bogota#ping 2001:db8:acad:110::1

Type escape sequence to abort.

Sending 5, 100-byte ICMP Echos to 2001:db8:acad:110::1, timeout is 2 seconds:

!!!!!

Success rate is 100 percent (5/5), round-trip min/avg/max = 3/7/21 ms

Bogota#ping 2001:db8:acad:90::1

Type escape sequence to abort.

Sending 5, 100-byte ICMP Echos to 2001:db8:acad:90::1, timeout is 2 seconds:

!!!!!

Success rate is 100 percent (5/5), round-trip min/avg/max = 5/9/11 ms

Bogota#ping 2001:db8:acad:90::2

Type escape sequence to abort.

Sending 5, 100-byte ICMP Echos to 2001:db8:acad:90::2, timeout is 2 seconds:

!!!!!

Success rate is 100 percent (5/5), round-trip min/avg/max = 1/9/21 ms

Bogota#ping 2001:db8:acad:91::1

Type escape sequence to abort.

Sending 5, 100-byte ICMP Echos to 2001:db8:acad:91::1, timeout is 2 seconds:

.....

Success rate is 0 percent (0/5)

Bogota#ping 2001:db8:acad:c::1

Type escape sequence to abort.

Sending 5, 100-byte ICMP Echos to 2001:db8:acad:c::1, timeout is 2 seconds:

.....
Success rate is 0 percent (0/5)

Bogota#ping 2001:db8:feed:1::1

Type escape sequence to abort.

Sending 5, 100-byte ICMP Echos to 2001:db8:feed:1::1, timeout is 2 seconds:

.....
Success rate is 0 percent (0/5)

Bogota#

- c. Verificar que las rutas filtradas no están presentes en las tablas de enrutamiento de los routers correctas.

Nota : Puede ser que Una o más direcciones no serán accesibles desde los routers después de la configuración final debido a la utilización de listas de distribución para filtrar rutas y el uso de IPv4 e IPv6 en la misma red.

Escenario 2

Una empresa de comunicaciones presenta una estructura Core acorde a la topología de red, en donde el estudiante será el administrador de la red, el cual deberá configurar e interconectar entre sí cada uno de los dispositivos que forman parte del escenario, acorde con los lineamientos establecidos para el direccionamiento IP, ethernet, VLANs y demás aspectos que forman parte del escenario propuesto.

Topología de red.



FIGURA 4 ESCENARIO 2



FIGURA 5 ESCENARIO 2 - DISPOSITIVOS ENCENDIDOS

Parte 1: Configurar la red de acuerdo con las especificaciones.

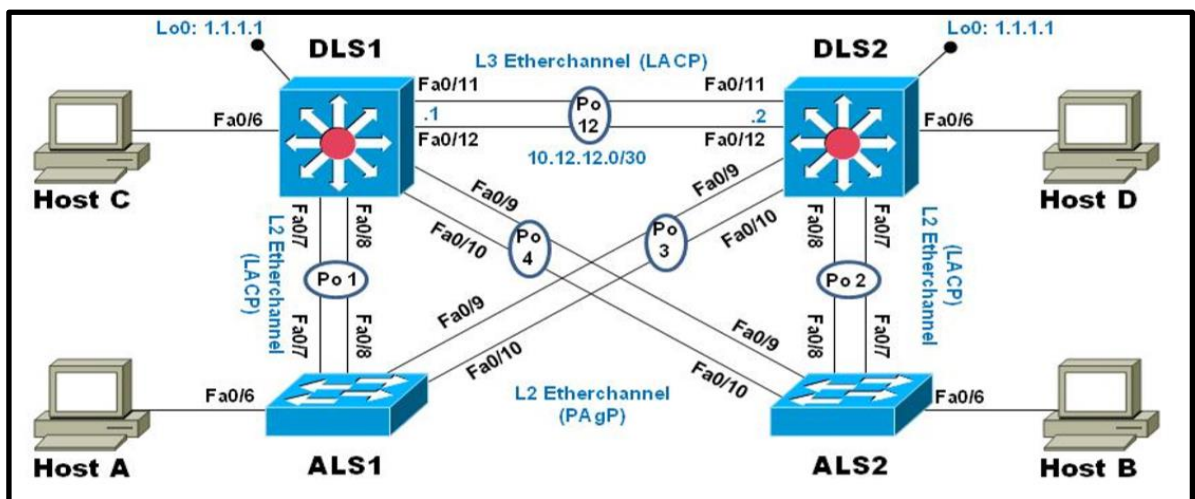
- a. Apagar todas las interfaces en cada switch.

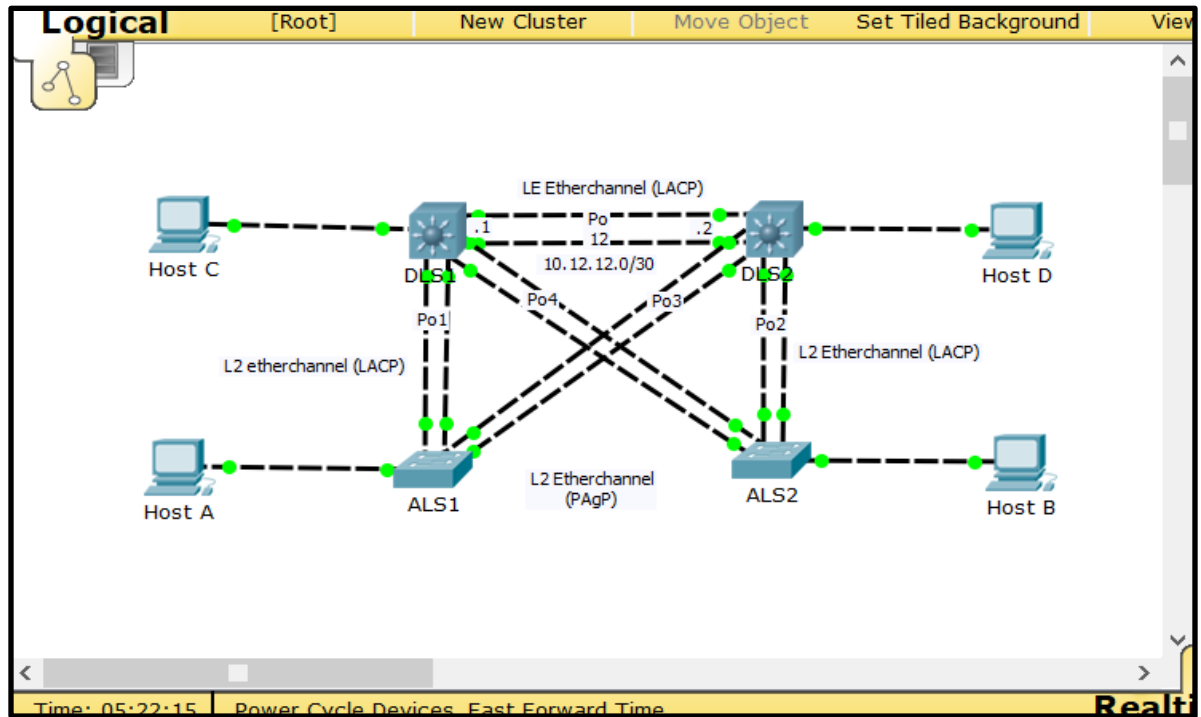

FIGURA 6 ESCENARIO 2 DISPOSITIVOS APAGADOS

ALS2

```
Switch>enable
```

```
Switch#config t
```

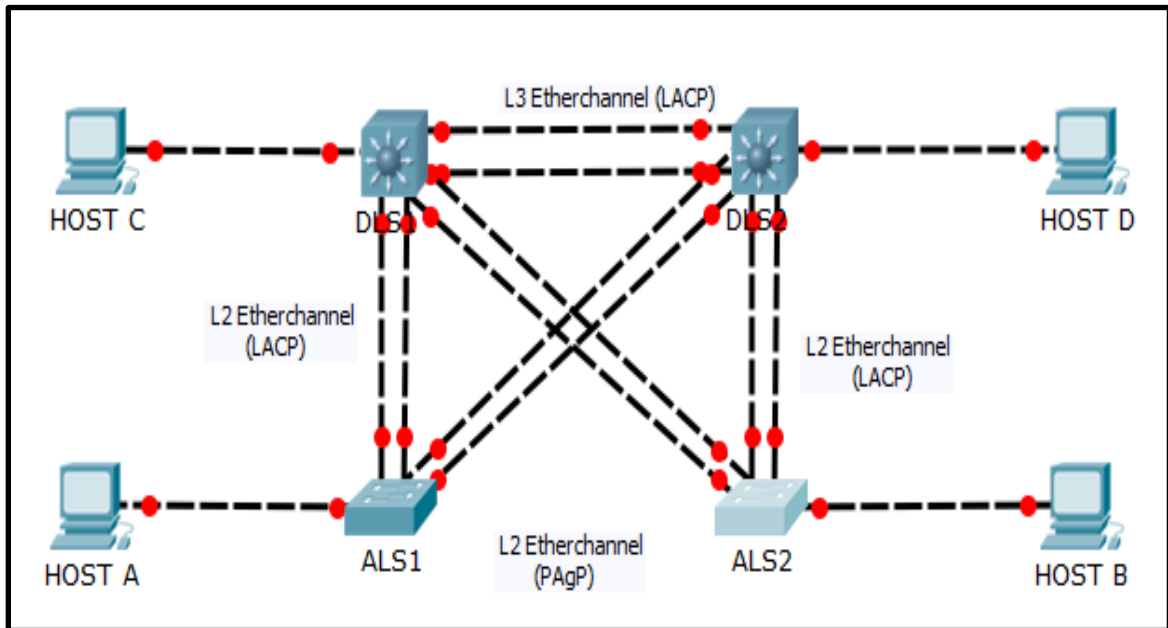
```
Enter configuration commands, one per line. End with CNTL/Z.
```

```
Switch(config)#int ran f0/1-24,g0/1-2
```

```
Switch(config-if-range)#shutdown
```

```
%LINK-5-CHANGED: Interface FastEthernet0/1, changed state to administratively down
```

```
%LINK-5-CHANGED: Interface FastEthernet0/2, changed state to administratively down
```

```
%LINK-5-CHANGED: Interface FastEthernet0/3, changed state to administratively down
```

```
%LINK-5-CHANGED: Interface FastEthernet0/4, changed state to administratively down
```

```
%LINK-5-CHANGED: Interface FastEthernet0/5, changed state to administratively down
```

```
%LINK-5-CHANGED: Interface FastEthernet0/7, changed state to administratively down
```

```
%LINK-5-CHANGED: Interface FastEthernet0/8, changed state to administratively down
```

```
%LINK-5-CHANGED: Interface FastEthernet0/9, changed state to administratively down
```

```
%LINK-5-CHANGED: Interface FastEthernet0/10, changed state to administratively down
```

```
%LINK-5-CHANGED: Interface FastEthernet0/11, changed state to administratively down
```

```
%LINK-5-CHANGED: Interface FastEthernet0/12, changed state to administratively down
```

```
%LINK-5-CHANGED: Interface FastEthernet0/13, changed state to administratively down
```

```
%LINK-5-CHANGED: Interface FastEthernet0/14, changed state to administratively down
```

```
%LINK-5-CHANGED: Interface FastEthernet0/15, changed state to administratively down
```

```
%LINK-5-CHANGED: Interface FastEthernet0/16, changed state to administratively down
```

```
%LINK-5-CHANGED: Interface FastEthernet0/17, changed state to administratively down
```

```
%LINK-5-CHANGED: Interface FastEthernet0/18, changed state to administratively down
```

```
%LINK-5-CHANGED: Interface FastEthernet0/19, changed state to administratively down
```

```
%LINK-5-CHANGED: Interface FastEthernet0/20, changed state to administratively
down
%LINK-5-CHANGED: Interface FastEthernet0/21, changed state to administratively
down
%LINK-5-CHANGED: Interface FastEthernet0/22, changed state to administratively
down
%LINK-5-CHANGED: Interface FastEthernet0/23, changed state to administratively
down
%LINK-5-CHANGED: Interface FastEthernet0/24, changed state to administratively
down
%LINK-5-CHANGED: Interface GigabitEthernet0/1, changed state to
administratively down
%LINK-5-CHANGED: Interface GigabitEthernet0/2, changed state to
administratively down
Switch(config-if-range)#
%LINK-5-CHANGED: Interface FastEthernet0/6, changed state to administratively
down
%LINEPROTO-5-UPDOWN: Line protocol on Interface FastEthernet0/6, changed
state to down
Switch(config-if-range)#exit
Switch(config)#
Switch#
%SYS-5-CONFIG_I: Configured from console by console
```

DLS2

```
Switch>enable
Switch#config t
Enter configuration commands, one per line. End with CNTL/Z.
Switch(config)#int ran f0/1-24,g0/1-2
Switch(config-if-range)#shutdown

%LINK-5-CHANGED: Interface FastEthernet0/1, changed state to administratively
down
%LINK-5-CHANGED: Interface FastEthernet0/2, changed state to administratively
down
%LINK-5-CHANGED: Interface FastEthernet0/3, changed state to administratively
down
%LINK-5-CHANGED: Interface FastEthernet0/4, changed state to administratively
down
%LINK-5-CHANGED: Interface FastEthernet0/5, changed state to administratively
down
%LINK-5-CHANGED: Interface FastEthernet0/11, changed state to administratively
down
%LINK-5-CHANGED: Interface FastEthernet0/12, changed state to administratively
down
```

%LINK-5-CHANGED: Interface FastEthernet0/13, changed state to administratively down
%LINK-5-CHANGED: Interface FastEthernet0/14, changed state to administratively down
%LINK-5-CHANGED: Interface FastEthernet0/15, changed state to administratively down
%LINK-5-CHANGED: Interface FastEthernet0/16, changed state to administratively down
%LINK-5-CHANGED: Interface FastEthernet0/17, changed state to administratively down
%LINK-5-CHANGED: Interface FastEthernet0/18, changed state to administratively down
%LINK-5-CHANGED: Interface FastEthernet0/19, changed state to administratively down
%LINK-5-CHANGED: Interface FastEthernet0/20, changed state to administratively down
%LINK-5-CHANGED: Interface FastEthernet0/21, changed state to administratively down
%LINK-5-CHANGED: Interface FastEthernet0/22, changed state to administratively down
%LINK-5-CHANGED: Interface FastEthernet0/23, changed state to administratively down
%LINK-5-CHANGED: Interface FastEthernet0/24, changed state to administratively down
%LINK-5-CHANGED: Interface GigabitEthernet0/1, changed state to administratively down
%LINK-5-CHANGED: Interface GigabitEthernet0/2, changed state to administratively down
Switch(config-if-range)#
%LINK-5-CHANGED: Interface FastEthernet0/6, changed state to administratively down
%LINEPROTO-5-UPDOWN: Line protocol on Interface FastEthernet0/6, changed state to down
%LINK-5-CHANGED: Interface FastEthernet0/7, changed state to administratively down
%LINEPROTO-5-UPDOWN: Line protocol on Interface FastEthernet0/7, changed state to down
%LINK-5-CHANGED: Interface FastEthernet0/8, changed state to administratively down
%LINEPROTO-5-UPDOWN: Line protocol on Interface FastEthernet0/8, changed state to down
%LINK-5-CHANGED: Interface FastEthernet0/9, changed state to administratively down
%LINEPROTO-5-UPDOWN: Line protocol on Interface FastEthernet0/9, changed state to down

```
%LINK-5-CHANGED: Interface FastEthernet0/10, changed state to administratively
down
%LINEPROTO-5-UPDOWN: Line protocol on Interface FastEthernet0/10, changed
state to down
exit
Switch(config)#
```

DLS1

```
Switch>enable
Switch#config t
Enter configuration commands, one per line. End with CNTL/Z.
Switch(config)#int ran f0/1-24,g0/1-2
Switch(config-if-range)#shutdown
```

```
%LINK-5-CHANGED: Interface FastEthernet0/2, changed state to administratively
down
%LINK-5-CHANGED: Interface FastEthernet0/3, changed state to administratively
down
%LINK-5-CHANGED: Interface FastEthernet0/4, changed state to administratively
down
%LINK-5-CHANGED: Interface FastEthernet0/5, changed state to administratively
down
%LINK-5-CHANGED: Interface FastEthernet0/11, changed state to administratively
down
%LINK-5-CHANGED: Interface FastEthernet0/13, changed state to administratively
down
%LINK-5-CHANGED: Interface FastEthernet0/14, changed state to administratively
down
%LINK-5-CHANGED: Interface FastEthernet0/15, changed state to administratively
down
%LINK-5-CHANGED: Interface FastEthernet0/16, changed state to administratively
down
%LINK-5-CHANGED: Interface FastEthernet0/17, changed state to administratively
down
%LINK-5-CHANGED: Interface FastEthernet0/18, changed state to administratively
down
%LINK-5-CHANGED: Interface FastEthernet0/19, changed state to administratively
down
%LINK-5-CHANGED: Interface FastEthernet0/20, changed state to administratively
down
%LINK-5-CHANGED: Interface FastEthernet0/21, changed state to administratively
down
```

%LINK-5-CHANGED: Interface FastEthernet0/22, changed state to administratively down
%LINK-5-CHANGED: Interface FastEthernet0/23, changed state to administratively down
%LINK-5-CHANGED: Interface FastEthernet0/24, changed state to administratively down
%LINK-5-CHANGED: Interface GigabitEthernet0/1, changed state to administratively down
%LINK-5-CHANGED: Interface GigabitEthernet0/2, changed state to administratively down

Switch(config-if-range)#

%LINK-5-CHANGED: Interface FastEthernet0/1, changed state to administratively down
%LINEPROTO-5-UPDOWN: Line protocol on Interface FastEthernet0/1, changed state to down
%LINK-5-CHANGED: Interface FastEthernet0/6, changed state to administratively down
%LINEPROTO-5-UPDOWN: Line protocol on Interface FastEthernet0/6, changed state to down
%LINK-5-CHANGED: Interface FastEthernet0/7, changed state to administratively down
%LINEPROTO-5-UPDOWN: Line protocol on Interface FastEthernet0/7, changed state to down
%LINK-5-CHANGED: Interface FastEthernet0/8, changed state to administratively down
%LINEPROTO-5-UPDOWN: Line protocol on Interface FastEthernet0/8, changed state to down
%LINK-5-CHANGED: Interface FastEthernet0/9, changed state to administratively down
%LINEPROTO-5-UPDOWN: Line protocol on Interface FastEthernet0/9, changed state to down
%LINK-5-CHANGED: Interface FastEthernet0/10, changed state to administratively down
%LINEPROTO-5-UPDOWN: Line protocol on Interface FastEthernet0/10, changed state to down
%LINK-5-CHANGED: Interface FastEthernet0/12, changed state to administratively down
%LINEPROTO-5-UPDOWN: Line protocol on Interface FastEthernet0/12, changed state to down
Switch(config-if-range)#exit
Switch(config)#

ALS1

```
Switch>enable
```

```
Switch#config t
```

```
Enter configuration commands, one per line. End with CNTL/Z.
```

```
Switch(config)#int ran f0/1-24,g0/1-2
```

```
Switch(config-if-range)#shutdown
```

```
%LINK-5-CHANGED: Interface FastEthernet0/1, changed state to administratively down
```

```
%LINK-5-CHANGED: Interface FastEthernet0/2, changed state to administratively down
```

```
%LINK-5-CHANGED: Interface FastEthernet0/3, changed state to administratively down
```

```
%LINK-5-CHANGED: Interface FastEthernet0/4, changed state to administratively down
```

```
%LINK-5-CHANGED: Interface FastEthernet0/5, changed state to administratively down
```

```
%LINK-5-CHANGED: Interface FastEthernet0/7, changed state to administratively down
```

```
%LINK-5-CHANGED: Interface FastEthernet0/8, changed state to administratively down
```

```
%LINK-5-CHANGED: Interface FastEthernet0/9, changed state to administratively down
```

```
%LINK-5-CHANGED: Interface FastEthernet0/10, changed state to administratively down
```

```
%LINK-5-CHANGED: Interface FastEthernet0/11, changed state to administratively down
```

```
%LINK-5-CHANGED: Interface FastEthernet0/12, changed state to administratively down
```

```
%LINK-5-CHANGED: Interface FastEthernet0/13, changed state to administratively down
```

```
%LINK-5-CHANGED: Interface FastEthernet0/14, changed state to administratively down
```

```
%LINK-5-CHANGED: Interface FastEthernet0/15, changed state to administratively down
```

```
%LINK-5-CHANGED: Interface FastEthernet0/16, changed state to administratively down
```

```
%LINK-5-CHANGED: Interface FastEthernet0/17, changed state to administratively down
```

```
%LINK-5-CHANGED: Interface FastEthernet0/18, changed state to administratively down
```

```
%LINK-5-CHANGED: Interface FastEthernet0/19, changed state to administratively down
```

```

%LINK-5-CHANGED: Interface FastEthernet0/20, changed state to administratively
down
%LINK-5-CHANGED: Interface FastEthernet0/21, changed state to administratively
down
%LINK-5-CHANGED: Interface FastEthernet0/22, changed state to administratively
down
%LINK-5-CHANGED: Interface FastEthernet0/23, changed state to administratively
down
%LINK-5-CHANGED: Interface FastEthernet0/24, changed state to administratively
down
%LINK-5-CHANGED: Interface GigabitEthernet0/1, changed state to
administratively down
%LINK-5-CHANGED: Interface GigabitEthernet0/2, changed state to
administratively down

Switch(config-if-range)#
%LINK-5-CHANGED: Interface FastEthernet0/6, changed state to administratively
down
%LINEPROTO-5-UPDOWN: Line protocol on Interface FastEthernet0/6, changed
state to down
exit
Switch(config)#

```

b. Asignar un nombre a cada switch acorde al escenario establecido.

DLS1

```

Switch>enable
Switch#config t
Enter Configuration commands, one per line. End with CNTL/Z.
Switch (config) #hostname DLS1
DLS1 (config) #

```

DLS2

```

Switch>enable
Switch#config t
Enter Configuration commands, one per line. End with CNTL/Z.
Switch (config) #hostname DLS2
DLS2 (config) #

```

ALS1

```
Switch>enable
Switch#config t
Enter Configuration commands, one per line. End with CNTL/Z.
Switch (config) #hostname ALS1
ALS1 (config) #
```

ALS2

```
Switch>enable
Switch#config t
Enter Configuration commands, one per line. End with CNTL/Z.
Switch (config) #hostname ALS2
ALS2 (config) #
```

c. Configurar los puertos troncales y Port-channels tal como se muestra en el diagrama.

- 1) La conexión entre DLS1 y DLS2 será un EtherChannel capa-3 utilizando LACP. Para DLS1 se utilizará la dirección IP 10.12.12.1/30 y para DLS2 utilizará 10.12.12.2/30.
- 2) Los Port-channels en las interfaces Fa0/7 y Fa0/8 utilizarán LACP.
- 3) Los Port-channels en las interfaces F0/9 y fa0/10 utilizará PAgP.
- 4) Todos los puertos troncales serán asignados a la VLAN 800 como la VLAN nativa.

DLS1

```
DLS1#config t
Enter Configuration commands, one per line. End with CNTL/Z.
DLS1 (config) #int ran f0/11-12
DLS1 (config-if-range) #no switchport
DLS1 (config-if-range) #channel-group 12 mode active
DLS1 (config-if-range) #
Creating a port-channel interface port-channel 12
```

```
DLS1 (config-if-range) #no shutdown
%LINK-5-CHANGED: Interface FastEthernet0/11, changed state to down
```

```
DLS1 (config-if-range) #
%LINK-5-CHANGED: Interface FastEthernet0/12, changed state to up
```

```
%LINEPROTO-5-UPDOWN: Line protocol on Interface FastEthernet0/12,
```

changed state to up

%LINK-5-CHANGED: Interface port-channel 12, changed state to up

%LINEPROTO-5-UPDOWN: Line protocol on Interface port-channel 12,
changed state to up

```
DLS1 (config-if-range) # exit
DLS1 (config) #int port-channel 12
DLS1 (config-if) # ip address 10.12.12.1 255.255.255.252
Bad mask 0Xff19FFFC for address 10.12.12.1
DLS1 (config-if) # ip address 10.12.12.1 255.255.255.252
DLS1 (config-if) #exit
DLS1 (config) #int ran f0/7-10
DLS1 (config-if-range) #switchport trunk encapsulation dot1q
DLS1 (config-if-range) #switchport trunk native vlan 800
DLS1 (config-if-range) #switchport mode trunk
DLS1 (config-if-range) #switchport nonegotiate
DLS1 (config-if-range) #no shutdown
```

```
%LINK-5-CHANGED: Interface FastEthernet0/7, changed state to down
%LINK-5-CHANGED: Interface FastEthernet0/8, changed state to down
%LINK-5-CHANGED: Interface FastEthernet0/9, changed state to down
%LINK-5-CHANGED: Interface FastEthernet0/10, changed state to down
```

```
DLS1 (config-if-range) # exit
DLS1 (config) # int ran f0/7-8
DLS1 (config-if-range) #desc member of pol to ALS1
DLS1 (config-if-range) # channel-group 1 mode active
DLS1 (config-if-range) #
Creating a port-channel interface port-channel 1
```

```
DLS1 (config-if-range) # exit
DLS1 (config) # int ran f0/9-10
DLS1 (config-if-range) #desc member of pol to ALS2
DLS1 (config-if-range) # channel-group 4 mode desirable
DLS1 (config-if-range) #
Creating a port-channel interface port-channel 4
```

DLS2

```
DLS2#config t
Enter Configuration commands, one per line. End with CNTL/Z.
DLS2 (config) #int ran f0/11-12
```

```

DLS2 (config-if-range) #no switchport
DLS2 (config-if-range) #channel-group 12 mode active
DLS2 (config-if-range) #no shutdown
DLS2 (config-if-range) #exit
DLS2 (config) #int port-channel 12
DLS2 (config-if) # ip address 10.12.12.1 255.255.255.252
DLS2 (config-if) #exit
DLS2 (config) #int ran f0/7-10
DLS2 (config-if-range) #switchport trunk encapsulation dot1q
DLS2 (config-if-range) #switchport trunk native vlan 800
DLS2 (config-if-range) #switchport mode trunk
DLS2 (config-if-range) #switchport nonegotiate
DLS2 (config-if-range) #no shutdown
DLS2 (config-if-range) # exit
DLS2(config) # int ran f0/7-8
DLS2 (config-if-range) #desc member of pol to ALS2
DLS2 (config-if-range) # channel-group 2 mode active
Command rejected (the interface Fa0/7 is) : is already part of cannel with a different
type of protocol enabled
Command rejected (the interface Fa0/8 is) : is already part of cannel with a different
type of protocol enabled
DLS2 (config-if-range) # exit
DLS2 (config) # int ran f0/9-10
DLS2 (config-if-range) #desc member of po3 to ALS1
DLS2 (config-if-range) # channel-group 3 mode desirable
DLS2 (config-if-range) #
Creating a port-channel interface port-channel 3

DLS2 (config-if-range) # exit
DLS2 (config)#

```

ALS1

```

ALS1#config t
Enter Configuration commands, one per line. End with CNTL/Z.
ALS1 (config) #int ran f0/7-10
ALS1 (config-if-range) #switchport trunk native vlan 800
ALS1 (config-if-range) #switchport mode trunk
ALS1 (config-if-range) #switchport nonegotiate
ALS1 (config-if-range) #no shutdown
ALS1(config) # int ran f0/7-8
ALS1 (config-if-range) #desc member of pol to DLS2
ALS1 (config-if-range) # channel-group 2 mode active
ALS1 (config-if-range) #

```

```
Creating a port-channel interface port-channel 2
ALS1 (config-if-range) #switchport trunk allowed vlan
12,123,234,800,1010,1111,3456
Command rejected: Bad VLAN list
Command rejected: Bad VLAN list
ALS1 (config-if-range) # no shutdown
```

```
ALS1 (config) # int ran f0/9-10
ALS1 (config-if-range) #desc member of po4 to DLS1
ALS1 (config-if-range) # channel-group 4
%CDP-4-NATIVE_VLAN_MISMATCH: Native mismatch discovered on port-
channel 2 (1), with DLS2 Fastethernet0/7 (800)
```

```
%CDP-4-NATIVE_VLAN_MISMATCH: Native mismatch discovered on port-
channel 2 (1), with DLS2 Fastethernet0/8 (800)
ALS1 (config-if-range) # channel-group 4 mode desirable
ALS1 (config-if-range) #
Creating a port-channel interface port-channel 4
```

```
ALS1 (config-if-range) #switchport trunk allowed vlan 12,123
```

```
%CDP-4-NATIVE_VLAN_MISMATCH: Native VLAN mismatch discovered on port-
channel 2 (1), with DLS2 Fastethernet0/7 (800)
```

```
%CDP-4-NATIVE_VLAN_MISMATCH: Native VLAN mismatch discovered on port-
channel 2 (1), with DLS2 Fastethernet0/8 (800)
```

```
ALS1      (Config-if-range)      #switchport      trunk      allowed      vlan
12,123,234,800,1010,1111,3456
Command rejected: Bad VLAN list
Command rejected: Bad VLAN list
ALS1 (config-if-range) #no shutdown
```

```
ALS1 (config) #ip default-gateway 10.34.56.254
```

ALS2

```
ALS2#config t
Enter Configuration commands, one per line. End with CNTL/Z.
ALS2 (config) #int ran f0/7-10
ALS2 (config-if-range) #switchport trunk native vlan 800
ALS2 (config-if-range) #switchport mode trunk
ALS2 (config-if-range) #switchport nonegotiate
```

```
ALS2 (config-if-range) #no shutdown
ALS2(config) # int ran f0/7-8
ALS2 (config-if-range) #desc member of pol to DLS2
ALS2 (config-if-range) # channel-group 2 mode active
ALS2 (config-if-range) #
Creating a port-channel interface port-channel 2
ALS2 (config-if-range) #switchport trunk allowed vlan
12,123,234,800,1010,1111,3456
Command rejected: Bad VLAN list
Command rejected: Bad VLAN list
ALS2 (config-if-range) # no shutdown
```

```
ALS2 (config) # int ran f0/9-10
ALS2 (config-if-range) #desc member of po4 to DLS1
ALS2 (config-if-range) # channel-group 4
%CDP-4-NATIVE_VLAN_MISMATCH: Native mismatch discovered on port-
channel 2 (1), with DLS2 Fastethernet0/7 (800)

%CDP-4-NATIVE_VLAN_MISMATCH: Native mismatch discovered on port-
channel 2 (1), with DLS2 Fastethernet0/8 (800)
ALS2 (config-if-range) # channel-group 4 mode desirable
ALS2 (config-if-range) #
Creating a port-channel interface port-channel 4
```

```
ALS2 (config-if-range) #switchport trunk allowed vlan 12,123
```

```
%CDP-4-NATIVE_VLAN_MISMATCH: Native VLAN mismatch discovered on port-
channel 2 (1), with DLS2 Fastethernet0/7 (800)
```

```
%CDP-4-NATIVE_VLAN_MISMATCH: Native VLAN mismatch discovered on port-
channel 2 (1), with DLS2 Fastethernet0/8 (800)
```

```
ALS2 (Config-if-range) #switchport trunk allowed vlan
12,123,234,800,1010,1111,3456
Command rejected: Bad VLAN list
Command rejected: Bad VLAN list
ALS2 (config-if-range) #no shutdown
```

```
ALS2 (config) #ip default-gateway 10.34.56.254
```

- d. Configurar DLS1, ALS1, y ALS2 para utilizar VTP versión 3
 - 1) Utilizar el nombre de dominio UNAD con la contraseña cisco 123.

DLS1

```
DLS1 (config) #vtp domain UNAD
Changing VTP domain name from NULL to UNAD
DLS1 (config) #vtp ver 3
DLS1 (config) #vtp version
%CDP-4-NATIVE_VLAN_MISMATCH: Native VLAM mismatch discovered on port-
channel 1 (1), with ALS1 FastEthernet0/7 (800) .
```

```
%CDP-4-NATIVE_VLAN_MISMATCH: Native VLAM mismatch discovered on port-
channel 1 (1), with ALS1 FastEthernet0/8 (800) .
```

```
DLS1 (config) #vtp password cisco123
Setting device VLAN database password to cisco123
DLS1(config) #
```

ALS1

```
ALS1 (config) #vtp domain UNAD
Domain name already set to UNAD.
ALS1 (config) #
```

```
%CDP-4-NATIVE_VLAN_MISMATCH: Native VLAM mismatch discovered on port-
channel 1 (1), with ALS1 FastEthernet0/9 (800) .
```

```
%CDP-4-NATIVE_VLAN_MISMATCH: Native VLAM mismatch discovered on port-
channel 3 (1), with DLS2 FastEthernet0/10 (800) .
```

```
ALS1 (config) #vtp password cisco123
Setting device VLAN database password to cisco123
DLS1(config) #
```

ALS2

```
ALS2 (config) #vtp domain UNAD
Domain name already set to UNAD.
ALS2 (config) #
```

```
%CDP-4-NATIVE_VLAN_MISMATCH: Native VLAM mismatch discovered on port-
channel 4 (1), with DLS1 FastEthernet0/9 (800) .
```

```
%CDP-4-NATIVE_VLAN_MISMATCH: Native VLAM mismatch discovered on port-
channel 4 (1), with DLS1 FastEthernet0/10 (800) .
ALS2 (config) #vtp password cisco123
Setting device VLAN database password to cisco123
```

ALS2(config) #

2) Configurar DLS1 como servidor principal para las VLAN.

DLS1

```
DLS1 (config) #vtp mode serv
Device mode already VTO SERVER.
DLS1 (config) #
```

3) Configurar ALS1 y ALS2 como clientes VTP.

ALS1

```
ALS1 (config) #vtp MODE CLIENT
Setting device to VTP CLIENT mode.
ALS1 (config) #
```

ALS2

```
ALS2 (config) #vtp MODE CLIENT
Setting device to VTP CLIENT mode.
ALS2 (config) #
```

e. Configurar en el servidor principal las siguientes VLAN:

Número VLAN	de Nombre de VLAN	Número VLAN	de Nombre de VLAN
800	NATIVA	434	ESTACIONAMIENTO
12	EJECUTIVOS	123	MANTENIMIENTO
234	HUESPEDES	1010	VOZ
1111	VIDEONET	3456	ADMINISTRACIÓN

TABLA 1 VLAN A CONFIGURAR

DLS1

```
DLS1 (config-vlan) #vlan 800
DLS1 (config-vlan) #name nativa
DLS1 (config-vlan) #exit
```

```
DLS1 (config-vlan) #vlan 434
DLS1 (config-vlan) #name estacionamiento
DLS1 (config-vlan) #exit
```

```
DLS1 (config-vlan) #vlan 12
DLS1 (config-vlan) #name ejecutivos
DLS1 (config-vlan) #exit
```

```
DLS1 (config-vlan) #vlan 123
DLS1 (config-vlan) #name mantenimiento
DLS1 (config-vlan) #exit
DLS1 (config) #
```

```
DLS1 (config-vlan) #vlan 234
DLS1 (config-vlan) #name huespedes
DLS1 (config-vlan) #exit
```

f. En DLS1, suspender la VLAN 434.

DLS1

```
DLS1 (config) #vlan 434
DLS1 (config-vlan) #state suspend
DLS1 (config-vlan) #exit
```

g. Configurar DLS2 en modo VTP transparente VTP utilizando VTP versión 2, y configurar en DLS2 las mismas VLAN que en DLS1.

DLS2

```
DLS2 (config) #vtp ver 2
VTP mode already in V2.
DLS2 (config) #vtp mode transparent
Device mode already VTP TRANSPARENT.
DLS2 (config) #vlan 800
DLS2 (config-vlan) #name nativa
```

```
DLS2 (config-vlan) #exit
DLS2 (config) #
DLS2 (config-vlan) #vlan 434
DLS2 (config-vlan) #name estacionamiento
DLS2 (config-vlan) #exit
DLS2 (config) #
DLS2 (config-vlan) #vlan 12
DLS2 (config-vlan) #name ejecutivos
DLS2 (config-vlan) #exit
DLS2 (config) #
DLS2 (config-vlan) #vlan 123
DLS2 (config-vlan) #name mantenimiento
DLS2 (config-vlan) #exit
DLS2 (config) #
DLS2 (config-vlan) #vlan 234
DLS2 (config-vlan) #name huespedes
DLS2 (config-vlan) #exit
```

h. Suspende VLAN 434 en DLS2

DLS2

```
DLS2 (config-vlan) #vlan 434
DLS2 (config-vlan) #state suspend
DLS2 (config-vlan) #exit
```

i. En DLS2, crear VLAN 567 con el nombre de CONTABILIDAD. La VLAN de CONTABILIDAD no podrá estar disponible en cualquier otro Switch de la red.

DLS2

```
DLS2 (config-vlan) #vlan 567
DLS2 (config-vlan) #name contabilidad
DLS2 (config-vlan) #exit
DLS2 (config) #
```

j. Configurar DLS1 como Spanning tree root para las VLAN 1, 12, 434, 800, 1010, 1111 y 3456 y como raíz secundaria para las VLAN 123 y 234.

DLS1

```
DLS1 (config) #spanning-tree vlan 1,12,434,800,1010,1111,3456 root primary
DLS1 (config) # spanning-tree vlan 123,234 root secondary
DLS1 (config) #exit
```

- k. Configurar DLS2 como Spanning tree root para las VLAN 123 y 234 y como una raíz secundaria para las VLAN 12, 434, 800, 1010, 1111 y 3456.

DLS1

```
DLS1 (config) #spanning-tree vlan 123,234 root primary
DLS1 (config) # spanning-tree vlan 1,12,434,800,1010,1111,3456 root secondary
DLS1 (config) #exit
```

- l. Configurar todos los puertos como troncales de tal forma que solamente las VLAN que se han creado se les permitirá circular a través de éstos puertos.

DLS1

```
DLS1 (config-if) #int port-channel 1
DLS1 (config-if) #switchport trunk allowed vlan 12,123,234, 800, 1010, 1111,3456
Command rejected: Bad VLAN list
DLS1 (config-if) #exit
DLS1 (config-if) #int port-channel 4
DLS1 (config-if) #switchport trunk allowed vlan 12,123,234, 800, 1010, 1111,3456
Command rejected: Bad VLAN list
DLS1 (config-if) #exit
```

DLS2

```
DLS1 (config-if) #int port-channel 2
DLS1 (config-if) #switchport trunk allowed vlan 12,123,234, 800, 1010, 1111,3456
Command rejected: Bad VLAN list
DLS1 (config-if) #exit
DLS1 (config-if) #int port-channel 3
DLS1 (config-if) #switchport trunk allowed vlan 12,123,234, 800, 1010, 1111,3456
Command rejected: Bad VLAN list
DLS1 (config-if) #exit
```

m. Configurar las siguientes interfaces como puertos de acceso, asignados a las VLAN de la siguiente manera:

INTERFAZ	DLS1	DLS2	ALS1	ALS2
Interfaz Fa0/6	3456	12, 1010	123, 1010	234
Interfaz Fa0/15	1111	1111	1111	1111
Interfaces F0 /16-18		567		

TABLA 2 INTERFACES COMO PUERTOS DE ACCESO

DLS1

```
DLS1 (config) #int f0/6
DLS1 (config-if) #switchport host
DLS1 (config-if) #switchport Access vlan 3456
DLS1 (config-if) #no shutdown
DLS1 (config-if) #exit
DLS1 (config) #int f0/15
DLS1 (config-if) #switchport host
DLS1 (config-if) #switchport Access vlan 1111
DLS1 (config-if) #no shutdown
DLS1 (config-if) #exit
```

DLS2

```
DLS2 (config) #int f0/6
DLS2 (config-if) #switchport host
DLS2 (config-if) #switchport Access vlan 12
DLS2 (config-if) #switchport voice vlan 1010
DLS2 (config-if) #no shutdown
DLS2 (config-if) #exit
DLS2 (config) #int f0/15
DLS2 (config-if) #switchport host
DLS2 (config-if) #switchport Access vlan 1111
DLS2 (config-if) #no shutdown
DLS2 (config-if) #exit
DLS2 (config) #int f0/16-18
DLS2 (config-if) #switchport host
DLS2 (config-if) #switchport Access vlan 567
DLS2 (config-if) #no shutdown
```

DLS2 (config-if) #exit

ALS1

```
ALS1 (config) #int f0/6
ALS1 (config-if) #switchport host
ALS1 (config-if) #switchport Access vlan 123
ALS1 (config-if) #switchport voice vlan 1010
ALS1 (config-if) #no shutdown
ALS1 (config-if) #exit
ALS1 (config) #int f0/15
ALS1 (config-if) #switchport host
ALS1 (config-if) #switchport Access vlan 1111
ALS1 (config-if) #no shutdown
ALS1 (config-if) #exit
```

ALS2

```
ALS2 (config) #int f0/6
ALS2 (config-if) #switchport host
ALS2 (config-if) #switchport Access vlan 234
ALS2 (config-if) #no shutdown
ALS2 (config-if) #exit
ALS2 (config) #int f0/15
ALS2 (config-if) #switchport host
ALS2 (config-if) #switchport Access vlan 1111
ALS2 (config-if) #no shutdown
ALS2 (config-if) #exit
```

Parte 2: conectividad de red de prueba y las opciones configuradas.

- a. Verificar la existencia de las VLAN correctas en todos los switches y la asignación de puertos troncales y de acceso.
- b. Verificar que el EtherChannel entre DLS1 y ALS1 está configurado correctamente.
- c. Verificar la configuración de Spanning tree entre DLS1 o DLS2 para cada VLAN.

CONCLUSIONES

A través de los diferentes temas vistos en el diplomado de profundización Cisco, se adquieren conocimientos más claros y específicos sobre los temas de Routing and Switching contemplados en la plataforma CISCO.

Por medio de los diversos software y plataformas virtuales se logra interactuar en el gran mundo de las telecomunicaciones y redes en donde se realizan pruebas y laboratorios sugeridos por el diplomado.

La prueba de habilidades consistió en el desarrollo de un número de dos escenarios en donde se buscó identificar el grado de competencias y habilidades de los diversos niveles de comprensión y solución de problemas relacionados con aspectos networking y adquiridos lo largo del diplomado

BIBLIOGRAFÍA

Froom, R., Frahim, E. (2015). CISCO Press (Ed). Spanning Tree Implementation. Implementing Cisco IP Switched Networks (SWITCH) Foundation Learning Guide CCNP SWITCH 300-115. Recuperado de <https://1drv.ms/b/s!AmlJYeiNT1IlnWR0hoMxgBNv1CJ>

Froom, R., Frahim, E. (2015). CISCO Press (Ed). InterVLAN Routing. Implementing Cisco IP Switched Networks (SWITCH) Foundation Learning Guide CCNP SWITCH 300-115. Recuperado de <https://1drv.ms/b/s!AmlJYeiNT1IlnWR0hoMxgBNv1CJ>

Teare, D., Vachon B., Graziani, R. (2015). CISCO Press (Ed). Basic Network and Routing Concepts. Implementing Cisco IP Routing (ROUTE) Foundation Learning Guide CCNP ROUTE 300-101. Recuperado de <https://1drv.ms/b/s!AmlJYeiNT1IlnMfy2rhPZHwEoWx>

UNAD (2015). Switch CISCO - Procedimientos de instalación y configuración del IOS [OVA]. Recuperado de <https://1drv.ms/u/s!AmlJYei-NT1IlyYRohwtwPUV64dg>

UNAD (2015). Switch CISCO Security Management [OVA]. Recuperado de <https://1drv.ms/u/s!AmlJYei-NT1IlyVeVJCCezJ2QE5c>