

DIPLOMADO DE PROFUNDIZACION CISCO PRUEBA DE  
HABILIDADES PRÁCTIAS CCNP

Héctor Alexander Quevedo Villamil

UNIVERSIDAD NACIONAL ABIERTA Y A DISTANCIA - UNAD  
ESCUELA DE CIENCIAS BÁSICAS, TECNOLOGÍA E INGENIERÍA - ECBTI  
INGENIERÍA EN TELECOMUNICACIONES  
2019

DIPLOMADO DE PROFUNDIZACION CISCO PRUEBA DE  
HABILIDADES PRÁCTICAS CCNP

Héctor Alexander Quevedo Villamil

Diplomado de opción de grado presentado para optar el título de  
INGENIERO EN TELECOMUNICACIONES

DIRECTOR:  
MSc. GERARDO GRANADOS ACUÑA

UNIVERSIDAD NACIONAL ABIERTA Y A DISTANCIA - UNAD  
ESCUELA DE CIENCIAS BÁSICAS, TECNOLOGÍA E INGENIERÍA - ECBTI  
INGENIERÍA EN TELECOMUNICACIONES  
2019

NOTA DE ACEPTACIÓN

---

---

---

---

---

---

---

---

---

Firma del Presidente del Jurado

---

Firma del Jurado

---

Firma del Jurado

Bogotá 12 de diciembre de 2019

## AGRADECIMIENTOS

Primero que todo, quiero dar gracias a Dios, ya que Él nos ha iluminado el camino y nos ha dado la fortaleza suficiente para alcanzar, con esfuerzo y dedicación, este galardón que tiene toda tu bendición.

He aquí un ejemplo de que los seres humanos también podemos idear proyectos que representan un progreso tanto individual como profesional. Efectivamente hoy, llegar a culminar este Diplomado, constituye el logro de un sueño para todos los participantes. Cada uno de nosotros realizamos diversas funciones en nuestros trabajos en algunas ocasiones afines a el título que deseamos obtener, pero todos traíamos las expectativas de ampliar nuestros conocimientos en el mundo del de las redes. Durante el tiempo que estuvimos desarrollando este en el Diplomado, sacrificamos tiempo con nuestras familias y es por eso que esto logro en porte también es de ellos por su comprensión y apoyo cuando decidimos emprender el sueño de ser ingenieros

## CONTENIDO

AGRADECIMIENTOS.....	4
CONTENIDO .....	5
LISTA DE FIGURAS .....	6
LISTA DE TABLAS.....	8
RESUMEN.....	9
ABSTRACT.....	9
INTRODUCCIÓN.....	10
DESARROLLO .....	11
ESCENARIO 1 .....	11
ROUTER .....	11
ESCENARIO 2 .....	27
SWITCH .....	27
CONCLUSIONES .....	58
BIBLIOGRAFÍA.....	59

## LISTA DE FIGURAS

Figura 1.Escenario 1.....	11
Figura 2.Simulación de escenario 1 .....	12
Figura 3.Direcciones IPv4 e IPv6.....	13
Figura 4.Direcciones IPv4 e IPv6.....	14
Figura 5.Direcciones IPv4 e IPv6.....	15
Figura 6.Ancho de banda.....	15
Figura 7.Ancho de banda.....	16
Figura 8.Ancho de banda.....	16
Figura 9.Direcciones OSPFv3.....	17
Figura 10.Direcciones OSPFv3.....	17
Figura 11.Area 1 de OSPF.....	18
Figura 12.OSPF área 0.....	19
Figura 13.Stubby .....	19
Figura 14.Rutas de IPv4 y IPv6 .....	20
Figura 15.Protocolo EIGRP .....	20
Figura 16.Protocolo EIGRP.....	21
Figura 17.Interfaces pasivas EIGRP .....	21
Figura 18.OSPF y EIGRP .....	22
Figura 19.Ruta 192.168.3.0/24 .....	22
Figura 20. Show ip route .....	23
Figura 21.Show ip route.....	23
Figura 22.Show ip route .....	24
Figura 23.Show ip route .....	24
Figura 24.Show ip route .....	25
Figura 25.Ping .....	25
Figura 26.Ping .....	26
Figura 27.Escenario 2.....	27
Figura 28.Simulación de Escenario 2.....	28
Figura 29.Apagado de puertos fastEthernet.....	29
Figura 30.Apagado de puertos GigabitEthernet .....	29
Figura 31.show interfaces Status .....	29
Figura 32.Apagado de puertos fastEthernet.....	30
Figura 33.Apagado de puertos GigabitEthernet .....	30
Figura 34.show interfaces Status .....	31
Figura 35.Apagado de puertos fastEtherne.....	32
Figura 36.Apagado de puertos GigabitEthernet .....	32
Figura 37.show interfaces Status .....	32
Figura 38.Apagado de puertos fastEthernet.....	33
Figura 39.Apagado de puertos GigabitEthernet .....	33
Figura 40.show interfaces Status.....	34
Figura 41.Nombre de switch DLS1 .....	34

Figura 42.Nombre de switch DLS2 .....	35
Figura 43.Nombre de switch ASL1.....	35
Figura 44.Nombre de switch ASL2.....	35
Figura 45.Troncales y Port-channels DLS1.....	36
Figura 46.Troncales y Port-channels DLS2.....	36
Figura 47.Port-channels DLS1 .....	37
Figura 48.Port-channels DLS2.....	37
Figura 49.Port-channels ASL1 .....	38
Figura 50.Port-channels ASL2 .....	38
Figura 51.interfaces F0/9 y fa0/10 DLS1.....	39
Figura 52.interfaces F0/9 y fa0/10 DLS2.....	39
Figura 53.interfaces F0/9 y fa0/10 ALS1 .....	39
Figura 54.interfaces F0/9 y fa0/10 ALS2 .....	40
Figura 55.VLAN 800 DLS1.....	40
Figura 56.VLAN 800 DLS2.....	41
Figura 57.VLAN 800 ASL1.....	41
Figura 58.VLAN 800 ASL2.....	42
Figura 59.Confi Contraseña DLS1 .....	42
Figura 60.VTP Mode Server DLS1.....	43
Figura 61.Clientes VTP ASL1 .....	43
Figura 62.Clientes VTP ASL2 .....	43
Figura 63.Servidor VLAN DLS1 .....	45
Figura 64.Servidor VLAN DLS2 .....	45
Figura 65.VLAN 434 DLS1.....	45
Figura 66.VLAN 434 DLS2.....	46
Figura 67.VLAN 434 DLS2.....	47
Figura 68.VLAN 567 DLS2.....	47
Figura 69.Spanning tree DLS1.....	47
Figura 70.Spanning tree DLS2.....	48
Figura 71.troncales DLS1 .....	49
Figura 72.troncales DLS2 .....	50
Figura 73.troncales ALS2 .....	51
Figura 74.troncales ALS2 .....	51
Figura 75.Asignados a las VLAN DLS1.....	52
Figura 76.Asignados a las VLAN DLS2.....	53
Figura 77.Asignados a las VLAN ASL1.....	53
Figura 78.Asignados a las VLAN ASL2.....	54
Figura 79.show vlan DSL1 .....	54
Figura 80.show vlan DSL2.....	55
Figura 81.show vlan ASL1 .....	55
Figura 82.show vlan ASL2 .....	56
Figura 83.show etherchannel DSL1 .....	56
Figura 84.show etherchannel ASL1 .....	57
Figura 85.show etherchannel.....	57

## LISTA DE TABLAS

Table 1.Interfaces Loopback para crear R1 .....	44
Table 2.Interfaces loopback para crear R2 .....	52

## RESUMEN

Este proyecto consiste en el proceso de conceptualización de los diversos temas del área de networking y seguridad los cuales se apreciaron durante el Diplomado de CCNP, a su vez la aplicación práctica de los mismos en la elaboración de diferentes esquemas topológicos de red en los laboratorios para los módulos de CCNP ROUTE y CCNA SWITCH en ambientes de simulación elaborados en software tales como GSN3 Y Packet Tracer.

El objetivo principal es el enriquecimiento del estudiante en un área de profundización del área de telecomunicaciones que permita poseer una base práctica para el mejoramiento del pensamiento crítico y la capacidad de análisis proactivo sobre plataforma de red, el análisis de situaciones conflictivas que permitan al estudiante entender el funcionamiento de corta mediana y gran envergadura.

Palabras Clave: Enrutamiento, Conmutación, Seguridad, Red

## ABSTRACT

This project consists of the process of conceptualization of the various topics of the area of networking and security which were appreciated during the CCNP Diploma, in turn the practical application of them in the development of different network topological schemes in laboratories to CCNP ROUTE and CCNA SWITCH modules in simulation environments developed in software such as GSN3 and Packet Tracer.

The main objective is the enrichment of the student in an area of deepening of the telecommunications area that allows to have a practical basis for the improvement of critical thinking and the ability of proactive analysis on a network platform, the analysis of conflict situations that allow the student to understand The operation of short medium and large wingspan.

Keywords: Routing, Switching, Security, NET.

## INTRODUCCIÓN

Durante esta actividad practica se desarrollaron dos escenarios (Uno con router y uno con switch) que permitían la configuración de diversos escenarios trabajados durante el diplomado, entre estos se encuentran las configuraciones básicas para ambos dispositivos (asignación de nombres, cableado, asignación de IP tanto IPv4 como IPv6, entre otros) así como la configuración de protocolos como Ethernet, OSPF, EIGRP, VTP, etc.

En este documento encontrará los comandos necesarios para realizar dichas configuraciones seguidas de la imagen que implementa esta en un software de diseño (GNS3, packet tracer o SmartLab) de acuerdo a las instrucciones dadas en la guía propuesta.

La importancia principal de esta actividad, es relacionar los comandos de acuerdo a una solicitud y necesidad específica, que permita la configuración avanzada tanto de routers como de switches, dando solución a un incidente que se puede presentar en nuestro ambiente laboral.

## DESARROLLO

### ESCENARIO 1

#### ROUTER

Una empresa de confecciones posee tres sucursales distribuidas en las ciudades de Bogotá, Medellín y Bucaramanga, en donde el estudiante será el administrador de la red, el cual deberá configurar e interconectar entre sí cada uno de los dispositivos que forman parte del escenario, acorde con los lineamientos establecidos para el direccionamiento IP, protocolos de enrutamiento y demás aspectos que forman parte de la topología de red.

Configurar la topología de red, de acuerdo con las siguientes especificaciones.

Figura 1. Escenario 1



Figura 2. Simulación de escenario 1

## Prueba de habilidades prácticas CCNP

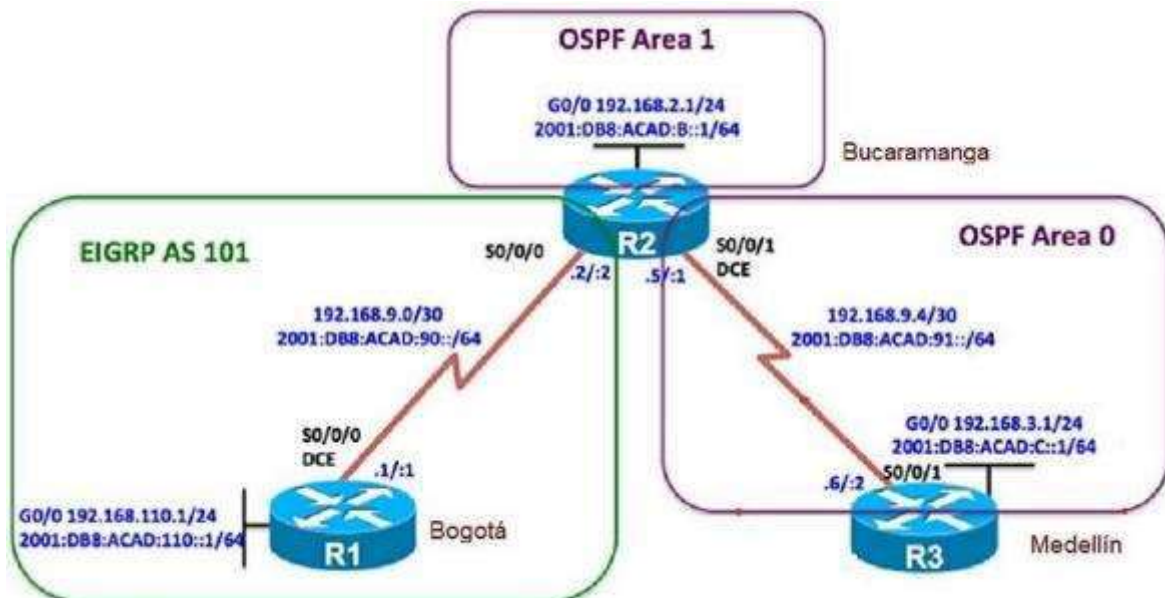
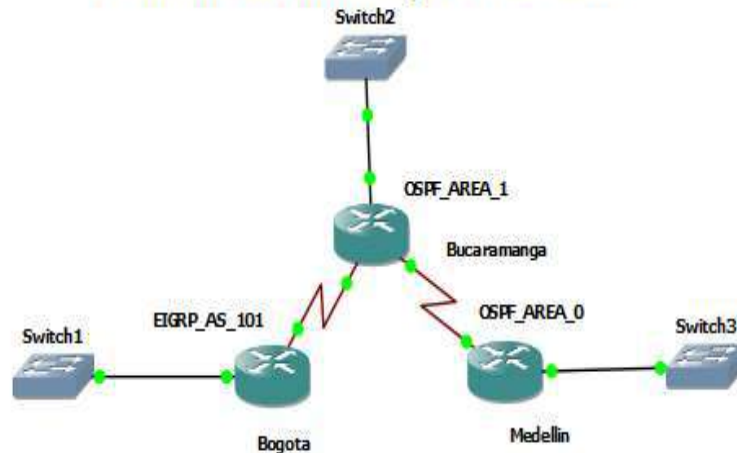

Hector Alexander Quevedo Villamil

Universidad Nacional Abierta y a Distancia UNAD

### Parte 1: Configuración del escenario propuesto

1. Configurar las interfaces con las direcciones IPv4 e IPv6 que se muestran en la topología de red.

Router 1 EIGRP\_AS\_101

```
no ip domain-lookup
line con 0
logging synchronous
exec-timeout 0 0
hostname EIGRP
interface gigabitEthernet0/0
ip address 192.168.110.1 255.255.255.0
ipv6 address 2001:db8:acad:110::1/64
speed auto
duplex auto
interface serial1/0
ip address 192.168.9.1 255.255.255.252
ipv6 address 2001:db8:acad:90::1/64
clock rate 64000
```

Figura 3. Direcciones IPv4 e IPv6

```
EIGRP_AS_101(config)#no ip domain-lookup
EIGRP_AS_101(config)#line con 0
EIGRP_AS_101(config-line)#logging synchronous
EIGRP_AS_101(config-line)#exec-timeout 0 0
EIGRP_AS_101(config-line)#
EIGRP_AS_101(config-line)#hostname EIGRP
EIGRP(config)#
EIGRP(config)#interface gigabitEthernet0/0
EIGRP(config-if)#ip address 192.168.110.1 255.255.255.0
EIGRP(config-if)#ipv6 address 2001:db8:acad:110::1/64
EIGRP(config-if)#speed auto
EIGRP(config-if)#duplex auto
EIGRP(config-if)#
EIGRP(config-if)#interface serial1/0
EIGRP(config-if)#ip address 192.168.9.1 255.255.255.252
EIGRP(config-if)#ipv6 address 2001:db8:acad:90::1/64
EIGRP(config-if)#clock rate 64000
EIGRP(config-if)#
```

#### Router 1 OSPF\_AREA\_1

```
no ip domain-lookup
line con 0
logging synchronous
exec-timeout 0 0
hostname OSPF_AREA_1
interface gigabitEthernet0/0
ip address 192.168.2.1 255.255.255.0
ipv6 address 2001:db8:acad:b::1/64
speed auto
duplex auto
interface serial1/0
ip address 192.168.9.2 255.255.255.252
ipv6 address 2001:db8:acad:91::1/64
interface serial1/1
ip address 192.168.9.5 255.255.255.252
ipv6 address 2001:db8:acad:91::1/64
clock rate 64000
```

Figura 4. Direcciones IPv4 e IPv6

```
r2(config)#no ip domain-lookup
r2(config)#line con 0
r2(config-line)#logging synchronous
r2(config-line)#exec-timeout 0 0
r2(config-line)#
r2(config-line)#hostname OSPF_AREA_1
OSPF_AREA_1(config)#
OSPF_AREA_1(config)#interface gigabitEthernet0/0
OSPF_AREA_1(config-if)#ip address 192.168.2.1 255.255.255.0
OSPF_AREA_1(config-if)#ipv6 address 2001:db8:acad:b::1/64
OSPF_AREA_1(config-if)#speed auto
OSPF_AREA_1(config-if)#duplex auto
OSPF_AREA_1(config-if)#
OSPF_AREA_1(config-if)#interface serial1/0
OSPF_AREA_1(config-if)#ip address 192.168.9.2 255.255.255.252
OSPF_AREA_1(config-if)#ipv6 address 2001:db8:acad:91::1/64
OSPF_AREA_1(config-if)#
OSPF_AREA_1(config-if)#interface serial1/1
OSPF_AREA_1(config-if)#ip address 192.168.9.5 255.255.255.252
OSPF_AREA_1(config-if)#ipv6 address 2001:db8:acad:91::1/64
%Serial1/1: Informational: 2001:DB8:ACAD:91::1/64 is in use on shutdown Serial1/0
OSPF_AREA_1(config-if)#clock rate 64000
OSPF_AREA_1(config-if)#
```

#### Router 1 OSPF\_AREA\_0

```
no ip domain-lookup
line con 0
logging synchronous
exec-timeout 0 0
hostname OSPF_AREA_0
interface gigabitEthernet0/0
ip address 192.168.3.1 255.255.255.0
ipv6 address 2001:db8:acad:c::1/64
speed auto
duplex auto
interface serial1/1
ip address 192.168.9.2 255.255.255.252
ipv6 address 2001:db8:acad:91::2/64
```

Figura 5. Direcciones IPv4 e IPv6

```
r3(config)#
r3(config)#no ip domain-lookup
r3(config)#line con 0
r3(config-line)#logging synchronous
r3(config-line)#exec-timeout 0 0
r3(config-line)#
r3(config-line)#hostname OSPF_AREA_0
OSPF_AREA_0(config)#
OSPF_AREA_0(config)#interface gigabitEthernet0/0
OSPF_AREA_0(config-if)#ip address 192.168.3.1 255.255.255.0
OSPF_AREA_0(config-if)#ipv6 address 2001:db8:acad:c::1/64
OSPF_AREA_0(config-if)#speed auto
OSPF_AREA_0(config-if)#duplex auto
OSPF_AREA_0(config-if)#
OSPF_AREA_0(config-if)#interface serial1/1
OSPF_AREA_0(config-if)#ip address 192.168.9.2 255.255.255.252
OSPF_AREA_0(config-if)#ipv6 address 2001:db8:acad:91::2/64
OSPF_AREA_0(config-if)#
OSPF_AREA_0(config-if)#
```

2. Ajustar el ancho de banda a 128 kbps sobre cada uno de los enlaces seriales ubicados en R1, R2, y R3 y ajustar la velocidad de reloj de las conexiones de DCE según sea apropiado.

Router 1 EIGRP\_AS\_101

```
interface serial1/0
bandwidth 128
```

Figura 6. Ancho de banda

```
EIGRP(config)#
EIGRP(config)#
EIGRP(config)#
EIGRP(config)#interface serial1/0
EIGRP(config-if)#bandwidth 128
EIGRP(config-if)#
```

Router 1 OSPF\_AREA\_1

```
interface serial1/0
bandwidth 128
interface serial1/1
bandwidth 128
```

Figura 7. Ancho de banda

```
OSPF_AREA_1(config)#interface serial1/0
OSPF_AREA_1(config-if)#bandwidth 128
OSPF_AREA_1(config-if)#
OSPF_AREA_1(config-if)#interface serial1/1
OSPF_AREA_1(config-if)#bandwidth 128
OSPF_AREA_1(config-if)#
```

Router 1 OSPF\_AREA\_0

```
interface serial1/1
bandwidth 128
```

Figura 8. Ancho de banda

```
OSPF_AREA_0(config)#
OSPF_AREA_0(config)#
OSPF_AREA_0(config)#interface serial1/1
OSPF_AREA_0(config-if)#bandwidth 128
OSPF_AREA_0(config-if)#
```

3. En R2 y R3 configurar las familias de direcciones OSPFv3 para IPv4 e IPv6. Utilice el identificador de enrutamiento 2.2.2.2 en R2 y 3.3.3.3 en R3 para ambas familias de direcciones.

Router 1 OSPF\_AREA\_1

```
ipv6 unicast-routing
interface GigabitEthernet0/0
ospfv3 1 ipv4 area 1
ospfv3 1 ipv6 area 1
exit
interface serial 1/0
ospfv3 1 ipv4 area 1
ospfv3 1 ipv6 area 1
exit
router ospfv3 1
address-family ipv4 unicast
router-id 2.2.2.2
```

Figura 9. Direcciones OSPFv3

```
OSPF_AREA_1(config)#ipv6 unicast-routing
OSPF_AREA_1(config)#interface GigabitEthernet0/0
OSPF_AREA_1(config-if)#ospfv3 1 ipv4 area 1
OSPF_AREA_1(config-if)#ospfv3 1 ipv6 area 1
OSPF_AREA_1(config-if)#exit
OSPF_AREA_1(config)#interface serial 1/0
OSPF_AREA_1(config-if)#ospfv3 1 ipv4 area 1
OSPF_AREA_1(config-if)#ospfv3 1 ipv6 area 1
OSPF_AREA_1(config-if)#exit
OSPF_AREA_1(config)#router ospfv3 1
OSPF_AREA_1(config-router)#address-family ipv4 unicast
OSPF_AREA_1(config-router-af)#router-id 2.2.2.2
*Dec  7 08:00:43.951: %OSPFv3-4-NORTRID: Process OSPFv3-1-IPv4 could not pic
OSPF_AREA_1(config-router-af)#router-id 2.2.2.2
OSPF_AREA_1(config-router-af)#
```

Router 1 OSPF\_AREA\_0

```
ipv6 unicast-routing
interface GigabitEthernet0/0
ospfv3 1 ipv4 area 0
ospfv3 1 ipv6 area 0
exit
interface serial1/1
ospfv3 1 ipv4 area 0
ospfv3 1 ipv6 area 0
exit
router ospfv3 1
address-family ipv4 unicast
router-id 3.3.3.3
```

Figura 10. Direcciones OSPFv3

```
OSPF_AREA_0(config)#ipv6 unicast-routing
OSPF_AREA_0(config)#interface GigabitEthernet0/0
OSPF_AREA_0(config-if)#ospfv3 1 ipv4 area 0
OSPF_AREA_0(config-if)#ospfv3 1 ipv6 area 0
OSPF_AREA_0(config-if)#exit
OSPF_AREA_0(config)#interface serial1/1
OSPF_AREA_0(config-if)#ospfv3 1 ipv4 area 0
OSPF_AREA_0(config-if)#ospfv3 1 ipv6 area 0
OSPF_AREA_0(config-if)#exit
OSPF_AREA_0(config)#router ospfv3 1
OSPF_AREA_0(config-router)#address-family ipv4 unicast
OSPF_AREA_0(config-router-af)#router-id 3.3.3.3
OSPF_AREA_0(config-router-af)#
*Dec  7 08:06:31.807: %OSPFv3-4-NORTRID: Process OSPFv3-1-IPv4 could not pic
OSPF_AREA_0(config-router-af)#
OSPF_AREA_0(config-router-af)#
```

4. En R2, configurar la interfaz F0/0 en el área 1 de OSPF y la conexión serial entre R2 y R3 en OSPF área 0.

Router 1 OSPF\_AREA\_1

```
interface GigabitEthernet0/0
ospf 1 ipv4 area 1
ospf 1 ipv6 area 1
exit
interface serial 1/0
ospf 1 ipv4 area 0
ospf 1 ipv6 area 0
exit
```

*Figura 11. Área 1 de OSPF*

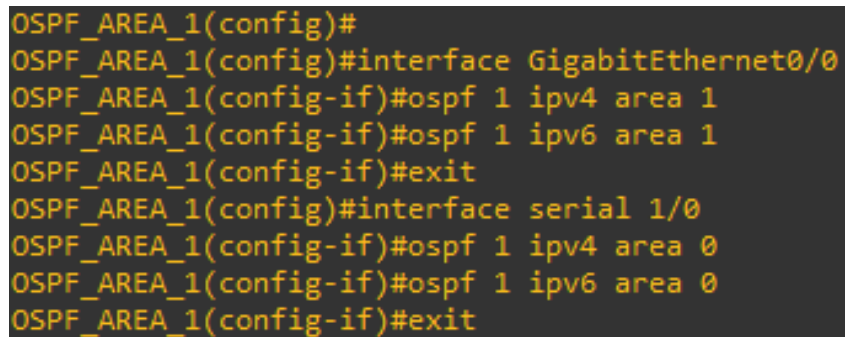

```
OSPF_AREA_1(config)#
OSPF_AREA_1(config)#interface GigabitEthernet0/0
OSPF_AREA_1(config-if)#ospf 1 ipv4 area 1
OSPF_AREA_1(config-if)#ospf 1 ipv6 area 1
OSPF_AREA_1(config-if)#exit
OSPF_AREA_1(config)#interface serial 1/0
OSPF_AREA_1(config-if)#ospf 1 ipv4 area 0
OSPF_AREA_1(config-if)#ospf 1 ipv6 area 0
OSPF_AREA_1(config-if)#exit
```

5. En R3, configurar la interfaz F0/0 y la conexión serial entre R2 y R3 en OSPF área 0.

Router 1 OSPF\_AREA\_0

```
interface GigabitEthernet0/0
ospf 1 ipv4 area 1
ospf 1 ipv6 area 1
exit
interface serial 1/1
ospf 1 ipv4 area 0
ospf 1 ipv6 area 0
exit
```

Figura 12.OSPF área 0

```
OSPF_AREA_0(config)#interface GigabitEthernet0/0
OSPF_AREA_0(config-if)#ospf 1 ipv4 area 1
OSPF_AREA_0(config-if)#ospf 1 ipv6 area 1
OSPF_AREA_0(config-if)#exit
OSPF_AREA_0(config)#interface serial 1/1
OSPF_AREA_0(config-if)#ospf 1 ipv4 area 0
OSPF_AREA_0(config-if)#ospf 1 ipv6 area 0
OSPF_AREA_0(config-if)#exit
OSPF_AREA_0(config)#
```

6. Configurar el área 1 como un área totalmente Stubby.

Router 1 OSPF\_AREA\_1

```
router ospfv3 1
area 1 stub no-summary
```

Figura 13.Stubby

```
OSPF_AREA_1(config)#
OSPF_AREA_1(config)#router ospfv3 1
OSPF_AREA_1(config-router)#area 1 stub no-summary
OSPF_AREA_1(config-router)#
```

7. Propagar rutas por defecto de IPv4 y IPv6 en R3 al interior del dominio OSPFv3. **Nota: Es importante tener en cuenta que una ruta por defecto es diferente a la definición de rutas estáticas.**

Router 1 OSPF\_AREA\_0

```
ip route 0.0.0.0 0.0.0.0 192.168.9.5
ipv6 route ::/0 2001:DB8:ACAD:91::1
router ospfv3 1
address-family ipv4 unicast
default-information originate
exit-address-family
address-family ipv6 unicast
default-information originate
exit-address-family
end
```

Figura 14. Rutas de IPv4 y IPv6

```
OSPF_AREA_0(config)#ip route 0.0.0.0 0.0.0.0 192.168.9.5
OSPF_AREA_0(config)#ipv6 route ::/0 2001:DB8:ACAD:91::1
OSPF_AREA_0(config)#router ospfv3 1
OSPF_AREA_0(config-router)#address-family ipv4 unicast
OSPF_AREA_0(config-router-af)#default-information originate
OSPF_AREA_0(config-router-af)#exit-address-family
OSPF_AREA_0(config-router)#address-family ipv6 unicast
OSPF_AREA_0(config-router-af)#default-information originate
OSPF_AREA_0(config-router-af)#exit-address-family
OSPF_AREA_0(config-router)#end
*Dec  8 10:43:24.023: %OSPFv3-4-NORTRID: Process OSPFv3-1-IPv4 could n
OSPF_AREA_0#
```

8. Realizar la configuración del protocolo EIGRP para IPv4 como IPv6. Configurar la interfaz F0/0 de R1 y la conexión entre R1 y R2 para EIGRP con el sistema autónomo 101. Asegúrese de que el resumen automático está desactivado.

Router 1 EIGRP\_AS\_101

```
ipv6 unicast-routing
router eigrp 101
no auto-summary
network 192.168.0.0
no shutdown
exit
interface g0/0
ipv6 eigrp 1
exit
interface s1/0
ipv6 eigrp 101
exit
```

Figura 15. Protocolo EIGRP

```
EIGRP(config)#ipv6 unicast-routing
EIGRP(config)#router eigrp 101
EIGRP(config-router)#no auto-summary
EIGRP(config-router)#network 192.168.0.0
EIGRP(config-router)#no shutdown
EIGRP(config-router)#exit
EIGRP(config)#interface g0/0
EIGRP(config-if)#ipv6 eigrp 1
EIGRP(config-if)#exit
EIGRP(config)#interface s1/0
EIGRP(config-if)#ipv6 eigrp 101
EIGRP(config-if)#exit
```

Router 1 OSPF\_AREA\_1

```
ipv6 unicast-routing
router eigrp 101
no auto-summary
network 192.168.0.0
no shutdown
interface s1/0
ipv6 eigrp 101
exit
```

Figura 16. Protocolo EIGRP

```
OSPF_AREA_1(config)#ipv6 unicast-routing
OSPF_AREA_1(config)#router eigrp 101
OSPF_AREA_1(config-router)#no auto-summary
OSPF_AREA_1(config-router)#network 192.168.0.0
OSPF_AREA_1(config-router)#no shutdown
OSPF_AREA_1(config-router)#exit
OSPF_AREA_1(config)#interface s1/0
OSPF_AREA_1(config-if)#ipv6 eigrp 101
OSPF_AREA_1(config-if)#exit
```

9. Configurar las interfaces pasivas para EIGRP según sea apropiado.

Router 1 EIGRP\_AS\_101

```
router eigrp 101
passive-interface serial1/1
end
```

Figura 17. Interfaces pasivas EIGRP

```
EIGRP(config)#router eigrp 101
EIGRP(config-router)#passive-interface serial1/1
EIGRP(config-router)#end
EIGRP#
```

10. En R2, configurar la redistribución mutua entre OSPF y EIGRP para IPv4 e IPv6. Asignar métricas apropiadas cuando sea necesario.

Router 1 OSPF\_AREA\_1

```
router ospf 1
redistribute eigrp 101 subnets
exit
```

```
router eigrp 1
```

```
redistribute ospf 1 metric 10000 100 255 1 1500
default-metric 10000 100 255 1 1500
redistribute ospf 1
end
```

Figura 18.OSPF y EIGRP

```
OSPF_AREA_1(config)#router ospf 1
OSPF_AREA_1(config-router)#redistribute eigrp 101 subnets
OSPF_AREA_1(config-router)#exit
OSPF_AREA_1(config)#router eigrp 1
OSPF_AREA_1(config-router)#redistribute ospf 1 metric 10000 100 255 1 1500
OSPF_AREA_1(config-router)#exit
OSPF_AREA_1(config)#default-metric 10000 100 255 1 1500
```

11. En R2, de hacer publicidad de la ruta 192.168.3.0/24 a R1 mediante una lista de distribución y ACL.

Router 1 OSPF\_AREA\_1

```
access-list 1 permit host 192.168.9.1
end
```

Figura 19.Ruta 192.168.3.0/24

```
OSPF_AREA_1(config)#access-list 1 permit host 192.168.9.1
OSPF_AREA_1(config)#end
OSPF_AREA_1#
*Dec  8 11:04:49.291: %SYS-5-CONFIG_I: Configured from console by console
```

## Parte 2: Verificar conectividad de red y control de la trayectoria.

- a. Registrar las tablas de enrutamiento en cada uno de los routers, acorde con los parámetros de configuración establecidos en el escenario propuesto.

#Enable

#Configure terminal

#Show ip route

## Router 1 EIGRP\_AS\_101

Figura 20. Show ip route

```
Codes: L - local, C - connected, S - static, R - RIP, M - mobile, B - BGP
D - EIGRP, EX - EIGRP external, O - OSPF, IA - OSPF inter area
N1 - OSPF NSSA external type 1, N2 - OSPF NSSA external type 2
E1 - OSPF external type 1, E2 - OSPF external type 2
I - IS-IS, su - IS-IS summary, L1 - IS-IS level-1, L2 - IS-IS level-2
ia - IS-IS inter area, * - candidate default, U - per-user static route
o - ODR, P - periodic downloaded static route, H - NHRP, I - LISP
+ - replicated route, % - next hop override

Gateway of last resort is 192.168.9.2 to network 0.0.0.0

D*EX 0.0.0.0/0 [170/50752000] via 192.168.9.2, 00:31:58, Serial3/0
D EX 192.168.2.0/24 [170/50752000] via 192.168.9.2, 00:31:58, Serial3/0
    192.168.9.0/24 is variably subnetted, 3 subnets, 2 masks
C    192.168.9.0/30 is directly connected, Serial3/0
L    192.168.9.1/32 is directly connected, Serial3/0
D EX 192.168.9.4/30 [170/50752000] via 192.168.9.2, 00:31:58, Serial3/0
    192.168.110.0/24 is variably subnetted, 2 subnets, 2 masks
C    192.168.110.0/24 is directly connected, GigabitEthernet1/0
L    192.168.110.1/32 is directly connected, GigabitEthernet1/0
```

Figura 21. Show ip route

```
IPv6 Routing Table - default - 7 entries
Codes: C - Connected, L - Local, S - Static, U - Per-user Static route
B - BGP, R - RIP, H - NHRP, I1 - ISIS L1
I2 - ISIS L2, IA - ISIS interarea, IS - ISIS summary, D - EIGRP
EX - EIGRP external, ND - ND Default, NDp - ND Prefix, DCE - Destination
NDR - Redirect, O - OSPF Intra, OI - OSPF Inter, OE1 - OSPF ext 1
OE2 - OSPF ext 2, ON1 - OSPF NSSA ext 1, ON2 - OSPF NSSA ext 2, I - LISP
EX ::/0 [170/50752000]
    via FE80::C802:16FF:FE64:0, Serial3/0
EX 2001:DB8:ACAD:C::/64 [170/50752000]
    via FE80::C802:16FF:FE64:0, Serial3/0
C 2001:DB8:ACAD:90::/64 [0/0]
    via Serial3/0, directly connected
L 2001:DB8:ACAD:90::1/128 [0/0]
    via Serial3/0, receive
C 2001:DB8:ACAD:110::/64 [0/0]
    via GigabitEthernet1/0, directly connected
L 2001:DB8:ACAD:110::1/128 [0/0]
    via GigabitEthernet1/0, receive
L FF00::/8 [0/0]
```

## Router 1 OSPF\_AREA\_1

Figura 22. Show ip route

```
Codes: L - local, C - connected, S - static, R - RIP, M - mobile, B - BGP
D - EIGRP, EX - EIGRP external, O - OSPF, IA - OSPF inter area
N1 - OSPF NSSA external type 1, N2 - OSPF NSSA external type 2
E1 - OSPF external type 1, E2 - OSPF external type 2
I - IS-IS, su - IS-IS summary, L1 - IS-IS level-1, L2 - IS-IS level-2
ia - IS-IS inter area, * - candidate default, U - per-user static route
o - ODR, P - periodic downloaded static route, H - NHRP, l - LISP
+ - replicated route, % - next hop override

Gateway of last resort is 192.168.9.6 to network 0.0.0.0

O*E2 0.0.0.0/0 [110/1] via 192.168.9.6, 02:27:48, Serial3/1
     192.168.2.0/24 is variably subnetted, 2 subnets, 2 masks
C     192.168.2.0/24 is directly connected, GigabitEthernet1/0
L     192.168.2.1/32 is directly connected, GigabitEthernet1/0
O     192.168.3.0/24 [110/782] via 192.168.9.6, 02:33:44, Serial3/1
     192.168.9.0/24 is variably subnetted, 4 subnets, 2 masks
C     192.168.9.0/30 is directly connected, Serial3/0
L     192.168.9.2/32 is directly connected, Serial3/0
C     192.168.9.4/30 is directly connected, Serial3/1
L     192.168.9.5/32 is directly connected, Serial3/1
O     192.168.110.0/24 [90/50245120] via 192.168.9.1, 00:34:07, Serial3/0
```

Figura 23. Show ip route

```
IPv6 Routing Table - Default - 10 entries
Codes: C - Connected, L - Local, S - Static, U - Per-user Static route
B - BGP, R - RIP, H - NHRP, I1 - ISIS L1
I2 - ISIS L2, IA - ISIS interarea, IS - ISIS summary, D - EIGRP
EX - EIGRP external, ND - ND Default, NDp - ND Prefix, DCE - Destination
NDR - Redirect, O - OSPF Intra, OI - OSPF Inter, OE1 - OSPF ext 1
OE2 - OSPF ext 2, ON1 - OSPF NSSA ext 1, ON2 - OSPF NSSA ext 2, l - LISP
OE1 ::/0 [110/1], tag 1
   via FE80::C803:1BFF:FE88:0, Serial3/1
C 2001:DB8:ACAD:B::/64 [0/0]
   via GigabitEthernet1/0, directly connected
L 2001:DB8:ACAD:B::1/128 [0/0]
   via GigabitEthernet1/0, receive
O 2001:DB8:ACAD:C::/64 [110/782]
   via FE80::C803:1BFF:FE88:0, Serial3/1
C 2001:DB8:ACAD:90::/64 [0/0]
   via Serial3/0, directly connected
L 2001:DB8:ACAD:90::2/128 [0/0]
   via Serial3/0, receive
C 2001:DB8:ACAD:91::/64 [0/0]
   via Serial3/1, directly connected
L 2001:DB8:ACAD:91::1/128 [0/0]
   via Serial3/1, receive
O 2001:DB8:ACAD:110::/64 [90/50245120]
   via FE80::C801:10FF:FE64:0, Serial3/0
L FF00::/8 [0/0]
```

## Router 1 OSPF\_AREA\_0

Figura 24. Show ip route

```
IPv6 Routing Table - default - 6 entries
Codes: C - Connected, L - Local, S - Static, U - Per-user Static route
       B - BGP, R - RIP, H - NHRP, I1 - ISIS L1
       I2 - ISIS L2, IA - ISIS interarea, IS - ISIS summary, D - EIGRP
       EX - EIGRP external, ND - ND Default, NDp - ND Prefix, DCE - Destination
       NDR - Redirect, O - OSPF Intra, OI - OSPF Inter, OE1 - OSPF ext 1
       OE2 - OSPF ext 2, ON1 - OSPF NSSA ext 1, ON2 - OSPF NSSA ext 2, I - IISP
OI 2001:DB8:ACAD:B::/64 [110/782]
   via FE80::C802:16FF:FE64:0, Serial3/1
C 2001:DB8:ACAD:C::/64 [0/0]
  via GigabitEthernet1/0, directly connected
L 2001:DB8:ACAD:C::1/128 [0/0]
  via GigabitEthernet1/0, receive
C 2001:DB8:ACAD:91::/64 [0/0]
  via Serial3/1, directly connected
L 2001:DB8:ACAD:91::2/128 [0/0]
  via Serial3/1, receive
L FF00::/8 [0/0]
```

- b. Verificar comunicación entre routers mediante el comando ping y traceroute

## R1 Router 1 EIGRP\_AS\_101

Figura 25. Ping

```
R1#ping 192.168.9.1
Type escape sequence to abort.
Sending 5, 100-byte ICMP Echos to 192.168.9.1, timeout is 2 seconds:
!!!!
Success rate is 100 percent (5/5), round-trip min/avg/max = 44/44/44 ms
R1#ping 192.168.9.2
Type escape sequence to abort.
Sending 5, 100-byte ICMP Echos to 192.168.9.2, timeout is 2 seconds:
!!!!
Success rate is 100 percent (5/5), round-trip min/avg/max = 20/22/24 ms
R1#ping 192.168.2.1
Type escape sequence to abort.
Sending 5, 100-byte ICMP Echos to 192.168.2.1, timeout is 2 seconds:
!!!!
Success rate is 100 percent (5/5), round-trip min/avg/max = 16/21/24 ms
R1#ping 192.168.9.5
Type escape sequence to abort.
Sending 5, 100-byte ICMP Echos to 192.168.9.5, timeout is 2 seconds:
!!!!
```

## Router 1 OSPF\_AREA\_1

Figura 26.Ping

```
R2#ping 192.168.110.1
Type escape sequence to abort.
Sending 5, 100-byte ICMP Echos to 192.168.110.1, timeout is 2 seconds:
!!!!
Success rate is 100 percent (5/5), round-trip min/avg/max = 4/12/24 ms
R2#ping 192.168.9.1
Type escape sequence to abort.
Sending 5, 100-byte ICMP Echos to 192.168.9.1, timeout is 2 seconds:
!!!!
Success rate is 100 percent (5/5), round-trip min/avg/max = 20/24/32 ms
R2#ping 192.168.9.2
Type escape sequence to abort.
Sending 5, 100-byte ICMP Echos to 192.168.9.2, timeout is 2 seconds:
!!!!
Success rate is 100 percent (5/5), round-trip min/avg/max = 44/56/108 ms
R2#ping 192.168.2.1
Type escape sequence to abort.
Sending 5, 100-byte ICMP Echos to 192.168.2.1, timeout is 2 seconds:
!!!!
Success rate is 100 percent (5/5), round-trip min/avg/max = 4/7/8 ms
R2#ping 192.168.9.5
Type escape sequence to abort.
Sending 5, 100-byte ICMP Echos to 192.168.9.5, timeout is 2 seconds:
!!!!
Success rate is 100 percent (5/5), round-trip min/avg/max = 20/52/172 ms
R2#ping 192.168.9.6
Type escape sequence to abort.
Sending 5, 100-byte ICMP Echos to 192.168.9.6, timeout is 2 seconds:
!!!!
Success rate is 100 percent (5/5), round-trip min/avg/max = 8/12/20 ms
R2#ping 192.168.3.1
Type escape sequence to abort.
Sending 5, 100-byte ICMP Echos to 192.168.3.1, timeout is 2 seconds:
!!!!
Success rate is 100 percent (5/5), round-trip min/avg/max = 8/26/88 ms
R2#
```

## Router 1 OSPF\_AREA\_0

- c. Verificar que las rutas filtradas no están presentes en las tablas de enrutamiento de los routers correctas.

## ESCENARIO 2

### SWITCH

Una empresa de comunicaciones presenta una estructura Core acorde a la topología de red, en donde el estudiante será el administrador de la red, el cual deberá configurar e interconectar entre sí cada uno de los dispositivos que forman parte del escenario, acorde con los lineamientos establecidos para el direccionamiento IP, etherchannels, VLANs y demás aspectos que forman parte del escenario propuesto.

Figura 27. Escenario 2



Figura 28. Simulación de Escenario 2



### Parte 1: Configurar la red de acuerdo con las especificaciones.

- Apagar todas las interfaces en cada switch.

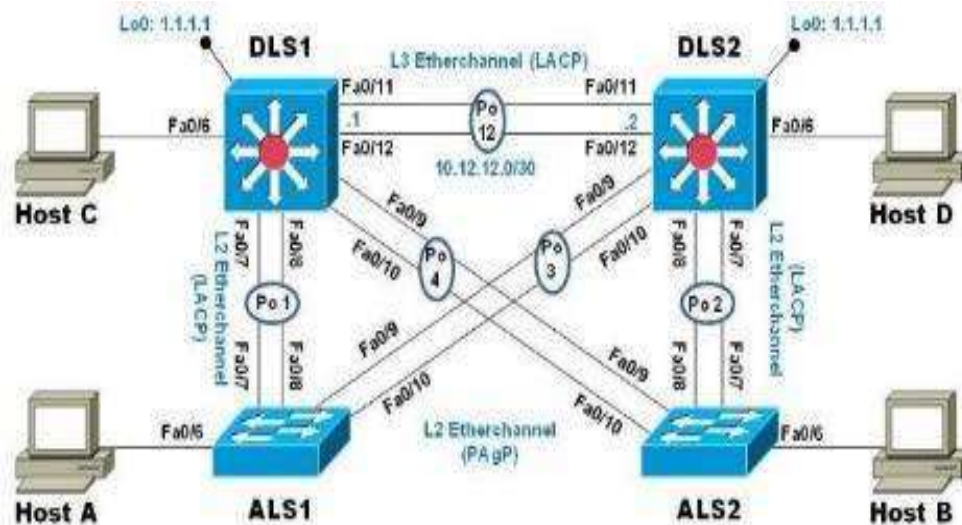
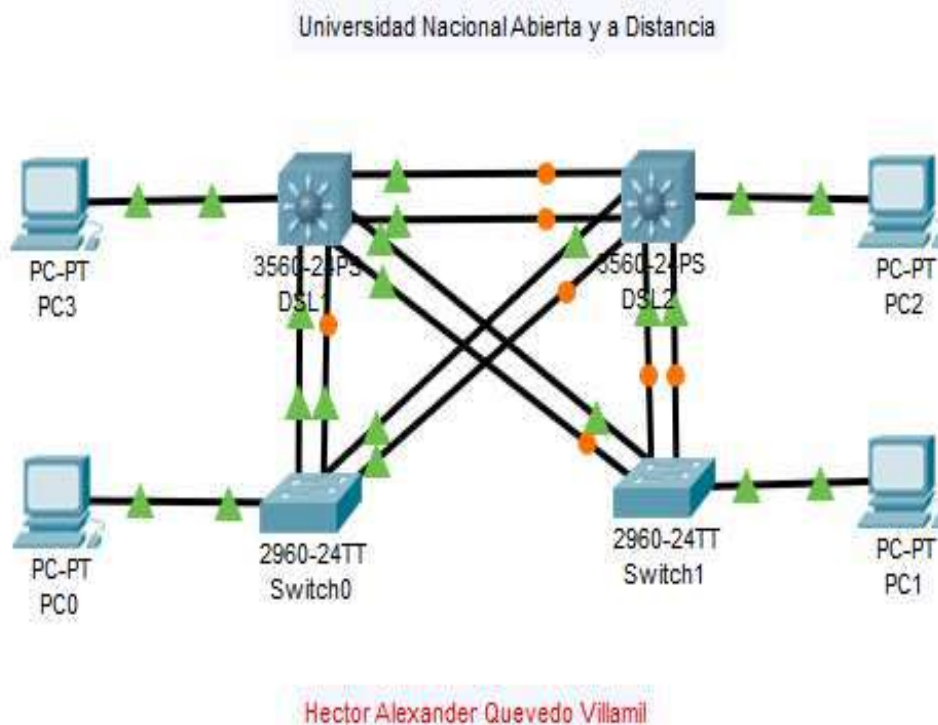
Switch DLS1

```
configureterminal
noipdomain-lookup
linecon0
loggingsynchronous
exec-timeout00
exit
interfacerangefastEthernet0/1-24
shutdown
exit
```

Figura 29. Apagado de puertos fastEthernet

```
sw(config)#  
sw(config)#interface range fastEthernet0/1-24  
sw(config-if-range)#shutdown
```

```
interfaceRangeGigabitEthernet0/1-2  
shutdown
```

Figura 30. Apagado de puertos GigabitEthernet

```
sw(config)#interface Range GigabitEthernet0/1-2  
sw(config-if-range)#shutdown
```

Figura 31. show interfaces Status

```
sw#sh int status
```

Port	Name	Status	Vlan	Duplex	Speed	Type
Po2		notconnect	1	auto	auto	
Fa0/1		disabled	1	auto	auto	10/100BaseTX
Fa0/2		disabled	1	auto	auto	10/100BaseTX
Fa0/3		disabled	1	auto	auto	10/100BaseTX
Fa0/4		disabled	1	auto	auto	10/100BaseTX
Fa0/5		disabled	1	auto	auto	10/100BaseTX
Fa0/6		disabled	1	auto	auto	10/100BaseTX
Fa0/7		disabled	1	auto	auto	10/100BaseTX
Fa0/8		disabled	1	auto	auto	10/100BaseTX
Fa0/9		disabled	1	auto	auto	10/100BaseTX
Fa0/10		disabled	1	auto	auto	10/100BaseTX
Fa0/11		disabled	1	auto	auto	10/100BaseTX
Fa0/12		disabled	1	auto	auto	10/100BaseTX
Fa0/13		disabled	1	auto	auto	10/100BaseTX
Fa0/14		disabled	1	auto	auto	10/100BaseTX
Fa0/15		disabled	1	auto	auto	10/100BaseTX
Fa0/16		disabled	1	auto	auto	10/100BaseTX
Fa0/17		disabled	1	auto	auto	10/100BaseTX
Fa0/18		disabled	1	auto	auto	10/100BaseTX
Fa0/19		disabled	1	auto	auto	10/100BaseTX
Fa0/20		disabled	1	auto	auto	10/100BaseTX
Fa0/21		disabled	1	auto	auto	10/100BaseTX
Fa0/22		disabled	1	auto	auto	10/100BaseTX
Fa0/23		disabled	1	auto	auto	10/100BaseTX
Fa0/24		disabled	1	auto	auto	10/100BaseTX
Gig0/1		disabled	1	auto	auto	10/100BaseTX
Gig0/2		disabled	1	auto	auto	10/100BaseTX

Switch DLS2

```
configureterminal  
noipdomain-lookup
```

```
linecon0
loggingsynchronous
exec-timeout00
exit
interfacerangefastEthernet0/1-24
shutdown
exit
```

Figura 32. Apagado de puertos fastEthernet

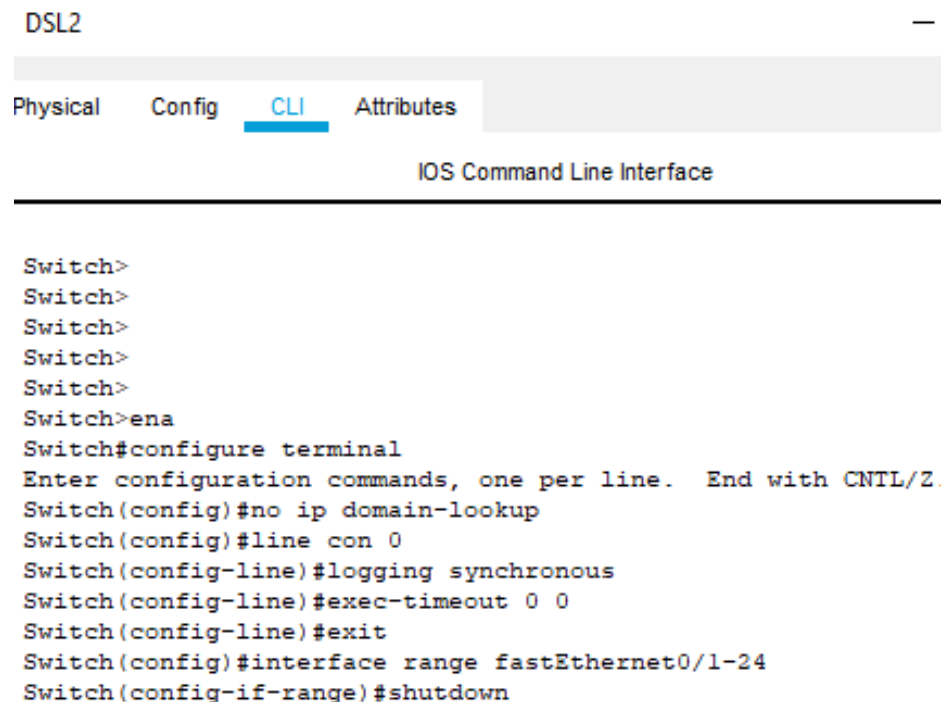

```
DSL2
Physical  Config  CLI  Attributes
IOS Command Line Interface

Switch>
Switch>
Switch>
Switch>
Switch>
Switch>ena
Switch#configure terminal
Enter configuration commands, one per line. End with CNTL/Z.
Switch(config)#no ip domain-lookup
Switch(config)#line con 0
Switch(config-line)#logging synchronous
Switch(config-line)#exec-timeout 0 0
Switch(config-line)#exit
Switch(config)#interface range fastEthernet0/1-24
Switch(config-if-range)#shutdown
```

```
interfaceRangeGigabitEthernet0/1-2
```

```
shutdown
```

Figura 33. Apagado de puertos GigabitEthernet

```
Switch(config-if-range)#shutdown

%LINK-5-CHANGED: Interface GigabitEthernet0/1, changed state to
administratively down

%LINK-5-CHANGED: Interface GigabitEthernet0/2, changed state to
administratively down
```

Figura 34.show interfaces Status

```
Switch#sh int status
Port      Name      Status      Vlan      Duplex  Speed  Type
Fa0/1     Fa0/1     disabled 1         auto    auto   10/100BaseTX
Fa0/2     Fa0/2     disabled 1         auto    auto   10/100BaseTX
Fa0/3     Fa0/3     disabled 1         auto    auto   10/100BaseTX
Fa0/4     Fa0/4     disabled 1         auto    auto   10/100BaseTX
Fa0/5     Fa0/5     disabled 1         auto    auto   10/100BaseTX
Fa0/6     Fa0/6     disabled 1         auto    auto   10/100BaseTX
Fa0/7     Fa0/7     disabled 1         auto    auto   10/100BaseTX
Fa0/8     Fa0/8     disabled 1         auto    auto   10/100BaseTX
Fa0/9     Fa0/9     disabled 1         auto    auto   10/100BaseTX
Fa0/10    Fa0/10    disabled 1         auto    auto   10/100BaseTX
Fa0/11    Fa0/11    disabled 1         auto    auto   10/100BaseTX
Fa0/12    Fa0/12    disabled 1         auto    auto   10/100BaseTX
Fa0/13    Fa0/13    disabled 1         auto    auto   10/100BaseTX
Fa0/14    Fa0/14    disabled 1         auto    auto   10/100BaseTX
Fa0/15    Fa0/15    disabled 1         auto    auto   10/100BaseTX
Fa0/16    Fa0/16    disabled 1         auto    auto   10/100BaseTX
Fa0/17    Fa0/17    disabled 1         auto    auto   10/100BaseTX
Fa0/18    Fa0/18    disabled 1         auto    auto   10/100BaseTX
Fa0/19    Fa0/19    disabled 1         auto    auto   10/100BaseTX
Fa0/20    Fa0/20    disabled 1         auto    auto   10/100BaseTX
Fa0/21    Fa0/21    disabled 1         auto    auto   10/100BaseTX
Fa0/22    Fa0/22    disabled 1         auto    auto   10/100BaseTX
Fa0/23    Fa0/23    disabled 1         auto    auto   10/100BaseTX
Fa0/24    Fa0/24    disabled 1         auto    auto   10/100BaseTX
Gig0/1    Gig0/1    disabled 1         auto    auto   10/100BaseTX
Gig0/2    Gig0/2    disabled 1         auto    auto   10/100BaseTX
```

Switch ALS1

```
configureterminal
noipdomain-lookup
linecon0
loggingsynchronous
exec-timeout00
exit
interfacerangefastEthernet0/1-24
shutdown
exit
```

Figura 35. Apagado de puertos fastEtherne

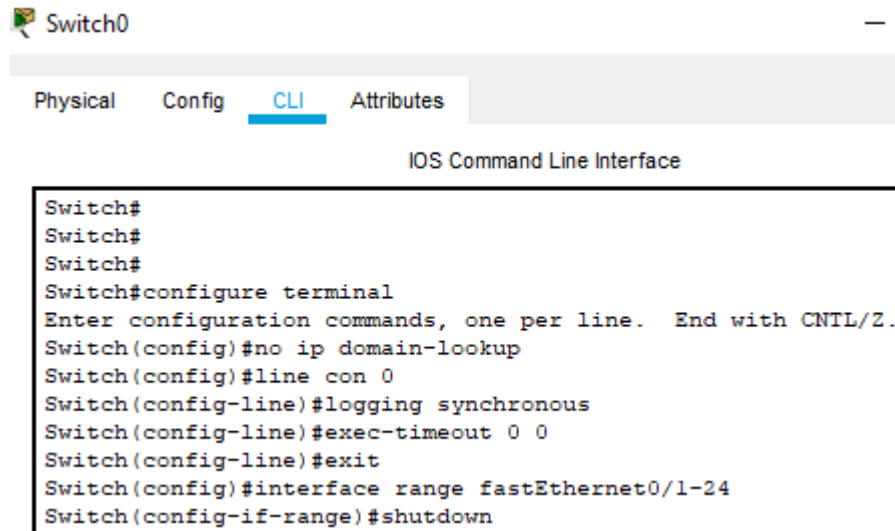

```
Switch0
Physical Config CLI Attributes
IOS Command Line Interface
Switch#
Switch#
Switch#
Switch#configure terminal
Enter configuration commands, one per line. End with CNTL/Z.
Switch(config)#no ip domain-lookup
Switch(config)#line con 0
Switch(config-line)#logging synchronous
Switch(config-line)#exec-timeout 0 0
Switch(config-line)#exit
Switch(config)#interface range fastEthernet0/1-24
Switch(config-if-range)#shutdown
```

```
interfaceRangeGigabitEthernet0/1-2
shutdown
```

Figura 36. Apagado de puertos GigabitEthernet

```
Switch(config)#interface Range GigabitEthernet0/1-2
Switch(config-if-range)#shutdown
```

Figura 37. show interfaces Status

```
Switch#sh int status
Port      Name          Status      Vlan      Duplex  Speed Type
Fa0/1     Fa0/1         disabled 1         auto    auto  10/100BaseTX
Fa0/2     Fa0/2         disabled 1         auto    auto  10/100BaseTX
Fa0/3     Fa0/3         disabled 1         auto    auto  10/100BaseTX
Fa0/4     Fa0/4         disabled 1         auto    auto  10/100BaseTX
Fa0/5     Fa0/5         disabled 1         auto    auto  10/100BaseTX
Fa0/6     Fa0/6         disabled 1         auto    auto  10/100BaseTX
Fa0/7     Fa0/7         disabled 1         auto    auto  10/100BaseTX
Fa0/8     Fa0/8         disabled 1         auto    auto  10/100BaseTX
Fa0/9     Fa0/9         disabled 1         auto    auto  10/100BaseTX
Fa0/10    Fa0/10        disabled 1         auto    auto  10/100BaseTX
Fa0/11    Fa0/11        disabled 1         auto    auto  10/100BaseTX
Fa0/12    Fa0/12        disabled 1         auto    auto  10/100BaseTX
Fa0/13    Fa0/13        disabled 1         auto    auto  10/100BaseTX
Fa0/14    Fa0/14        disabled 1         auto    auto  10/100BaseTX
Fa0/15    Fa0/15        disabled 1         auto    auto  10/100BaseTX
Fa0/16    Fa0/16        disabled 1         auto    auto  10/100BaseTX
Fa0/17    Fa0/17        disabled 1         auto    auto  10/100BaseTX
Fa0/18    Fa0/18        disabled 1         auto    auto  10/100BaseTX
Fa0/19    Fa0/19        disabled 1         auto    auto  10/100BaseTX
Fa0/20    Fa0/20        disabled 1         auto    auto  10/100BaseTX
Fa0/21    Fa0/21        disabled 1         auto    auto  10/100BaseTX
Fa0/22    Fa0/22        disabled 1         auto    auto  10/100BaseTX
Fa0/23    Fa0/23        disabled 1         auto    auto  10/100BaseTX
Fa0/24    Fa0/24        disabled 1         auto    auto  10/100BaseTX
Gig0/1    Gig0/1        disabled 1         auto    auto  10/100BaseTX
Gig0/2    Gig0/2        disabled 1         auto    auto  10/100BaseTX
```

## Switch ALS2

```
configure terminal
no ip domain-lookup
line con 0
logging synchronous
exec-timeout 0 0
exit
interface range fastEthernet0/1-24
shutdown
exit
```

Figura 38. Apagado de puertos fastEthernet

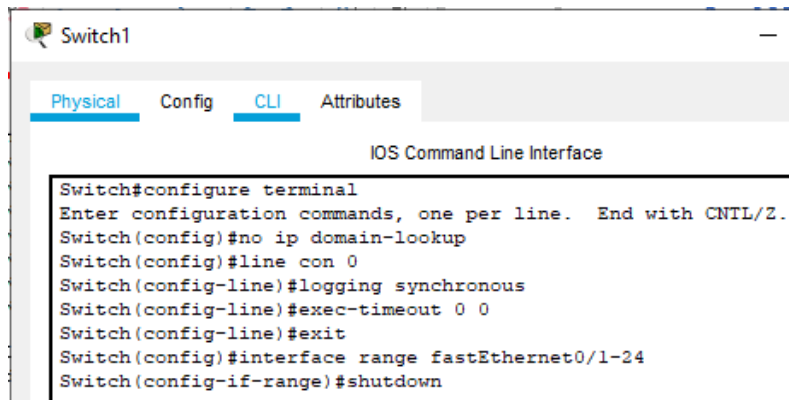

```
Switch1
Physical Config CLI Attributes
IOS Command Line Interface
Switch#configure terminal
Enter configuration commands, one per line. End with CNTL/Z.
Switch(config)#no ip domain-lookup
Switch(config)#line con 0
Switch(config-line)#logging synchronous
Switch(config-line)#exec-timeout 0 0
Switch(config-line)#exit
Switch(config)#interface range fastEthernet0/1-24
Switch(config-if-range)#shutdown
```

```
interface Range GigabitEthernet0/1-2
shutdown
```

Figura 39. Apagado de puertos GigabitEthernet

```
Switch(config)#interface Range GigabitEthernet0/1-2
Switch(config-if-range)#shutdown
%LINK-5-CHANGED: Interface FastEthernet0/6, changed state to
administratively down
```

Figura 40. show interfaces Status

```
Switch#sh int status
Port      Name      Status      Vlan      Duplex  Speed  Type
Fa0/1     Fa0/1     disabled 1         auto    auto   10/100BaseTX
Fa0/2     Fa0/2     disabled 1         auto    auto   10/100BaseTX
Fa0/3     Fa0/3     disabled 1         auto    auto   10/100BaseTX
Fa0/4     Fa0/4     disabled 1         auto    auto   10/100BaseTX
Fa0/5     Fa0/5     disabled 1         auto    auto   10/100BaseTX
Fa0/6     Fa0/6     disabled 1         auto    auto   10/100BaseTX
Fa0/7     Fa0/7     disabled 1         auto    auto   10/100BaseTX
Fa0/8     Fa0/8     disabled 1         auto    auto   10/100BaseTX
Fa0/9     Fa0/9     disabled 1         auto    auto   10/100BaseTX
Fa0/10    Fa0/10    disabled 1         auto    auto   10/100BaseTX
Fa0/11    Fa0/11    disabled 1         auto    auto   10/100BaseTX
Fa0/12    Fa0/12    disabled 1         auto    auto   10/100BaseTX
Fa0/13    Fa0/13    disabled 1         auto    auto   10/100BaseTX
Fa0/14    Fa0/14    disabled 1         auto    auto   10/100BaseTX
Fa0/15    Fa0/15    disabled 1         auto    auto   10/100BaseTX
Fa0/16    Fa0/16    disabled 1         auto    auto   10/100BaseTX
Fa0/17    Fa0/17    disabled 1         auto    auto   10/100BaseTX
Fa0/18    Fa0/18    disabled 1         auto    auto   10/100BaseTX
Fa0/19    Fa0/19    disabled 1         auto    auto   10/100BaseTX
Fa0/20    Fa0/20    disabled 1         auto    auto   10/100BaseTX
Fa0/21    Fa0/21    disabled 1         auto    auto   10/100BaseTX
Fa0/22    Fa0/22    disabled 1         auto    auto   10/100BaseTX
Fa0/23    Fa0/23    disabled 1         auto    auto   10/100BaseTX
Fa0/24    Fa0/24    disabled 1         auto    auto   10/100BaseTX
Gig0/1    Gig0/1    disabled 1         auto    auto   10/100BaseTX
Gig0/2    Gig0/2    disabled 1         auto    auto   10/100BaseTX
```

- b. Asignar un nombre a cada switch acorde al escenario establecido.

Switch DLS1

DLS1

```
configureterminal
```

```
hostnameDSL1
```

```
end
```

```
wr
```

Figura 41. Nombre de switch DLS1

```
sw#configure terminal
Enter configuration commands, one per line. End with CNTL/Z.
sw(config)#hostname DSL1
DSL1(config)#end
DSL1#wr
%SYS-5-CONFIG_I: Configured from console by console
```

Switch DLS2

```
configureterminal
```

```
hostnameDSL2
```

```
end
wr
```

*Figura 42. Nombre de switch DLS2*

```
Switch#configure terminal
Enter configuration commands, one per line. End with CNTL/Z.
Switch(config)#hostname DSL2
DSL2(config)#end
DSL2#wr
%SYS-5-CONFIG_I: Configured from console by console
```

Switch ALS1

```
configureterminal
hostnameASL1
end
wr
```

*Figura 43. Nombre de switch ASL1*

```
Switch#configure terminal
Enter configuration commands, one per line. End with CNTL/Z.
Switch(config)#hostname ASL1
ASL1(config)#end
ASL1#wr
%SYS-5-CONFIG_I: Configured from console by console
```

Switch ALS2

```
configureterminal
hostnameASL2
end
wr
```

*Figura 44. Nombre de switch ASL2*

```
Switch#configure terminal
Enter configuration commands, one per line. End with CNTL/Z.
Switch(config)#hostname ASL2
ASL2(config)#end
ASL2#wr
%SYS-5-CONFIG_I: Configured from console by console
```

- c. Configurar los puertos troncales y Port-channels tal como se muestra en el diagrama.
  - 1) La conexión entre DLS1 y DLS2 será un EtherChannel capa-3 utilizando LACP. Para DLS1 se utilizará la dirección IP 10.12.12.1/30 y para DLS2 utilizará 10.12.12.2/30.

### Switch DLS1

```
interfacevlan800
ipaddress10.12.12.1255.255.255.252
interfacerangef0/11-12
channel-protocollacp
channel-group2modeactive
noshutdown
```

*Figura 45. Troncales y Port-channels DLS1*

```
DSL1(config)#interface vlan 800
DSL1(config-if)#ip address 10.12.12.1 255.255.255.252
DSL1(config-if)#interface range f0/11-12
DSL1(config-if-range)#channel-protocol lacp
DSL1(config-if-range)#channel-group 2 mode active
DSL1(config-if-range)#no shutdown
```

### Switch DLS2

```
interfacevlan800
ipaddress10.12.12.2255.255.255.252
interfacerangef0/11-12
channel-protocollacp
channel-group2modeactive
noshutdown
```

*Figura 46. Troncales y Port-channels DLS2*

```
DSL2(config)#interface vlan 800
DSL2(config-if)#ip address 10.12.12.2 255.255.255.252
DSL2(config-if)#interface range f0/11-12
DSL2(config-if-range)#channel-protocol lacp
DSL2(config-if-range)#channel-group 2 mode active
DSL2(config-if-range)#no shutdown
Creating a port-channel interface Port-channel 2

DSL2(config-if-range)#no shutdown
```

- 2) Los Port-channels en las interfaces Fa0/7 y Fa0/8 utilizarán LACP.

### Switch DLS1

```
interfacerangef0/7-8
channel-protocollacp
channel-group2modeactive
noshutdown
end
```

Figura 47.Port-channels DLS1

```
DSL1(config)#interface range f0/7-8
DSL1(config-if-range)#channel-protocol lacp
DSL1(config-if-range)#channel-group 2 mode active
DSL1(config-if-range)#no shutdown

%LINK-5-CHANGED: Interface FastEthernet0/7, changed state to down

%LINK-5-CHANGED: Interface FastEthernet0/8, changed state to down
DSL1(config-if-range)#end
DSL1#
%SYS-5-CONFIG_I: Configured from console by console
```

### Switch DLS2

```
interfacerangef0/7-8
channel-protocollacp
channel-group2modeactive
noshutdown
end
```

Figura 48.Port-channels DLS2

```
DSL2(config)#interface range f0/7-8
DSL2(config-if-range)#channel-protocol lacp
DSL2(config-if-range)#channel-group 2 mode active
DSL2(config-if-range)#no shutdown

%LINK-5-CHANGED: Interface FastEthernet0/7, changed state to down

%LINK-5-CHANGED: Interface FastEthernet0/8, changed state to down
DSL2(config-if-range)#end
DSL2#
%SYS-5-CONFIG I: Configured from console by console
```

### Switch ALS1

```
interfacerangef0/7-8
channel-protocollacp
channel-group2modeactive
noshutdown
end
```

Figura 49.Port-channels ASL1

```
ASL1(config)#interface range f0/7-8
ASL1(config-if-range)#channel-protocol lacp
ASL1(config-if-range)#channel-group 2 mode active
ASL1(config-if-range)#no shutdown

ASL1(config-if-range)#end
Creating a port-channel interface Port-channel 2
```

### Switch ALS2

```
interfacerangef0/7-8
channel-protocollacp
channel-group2modeactive
noshutdown
end
```

Figura 50.Port-channels ASL2

```
ASL2(config)#interface range f0/7-8
ASL2(config-if-range)#channel-protocol lacp
ASL2(config-if-range)#channel-group 2 mode active
ASL2(config-if-range)#no shutdown

ASL2(config-if-range)#end
Creating a port-channel interface Port-channel 2

%LINK-5-CHANGED: Interface FastEthernet0/7, changed state to up

%LINEPROTO-5-UPDOWN: Line protocol on Interface FastEthernet0/7,
changed state to up

%LINK-5-CHANGED: Interface FastEthernet0/8, changed state to up

%LINEPROTO-5-UPDOWN: Line protocol on Interface FastEthernet0/8,
changed state to up

ASL2(config-if-range)#end
ASL2#
%SYS-5-CONFIG_I: Configured from console by console

ASL2#
```

- 3) Los Port-channels en las interfaces F0/9 y fa0/10 utilizará PAgP.

### Switch DLS1

```
interfacerangef0/9-10
channel-protocolpagp
channel-group2modedesirable
noshutdown
end
```

Figura 51.interfaces F0/9 y fa0/10 DLS1

```
DSL1(config)#interface range f0/9-10
DSL1(config-if-range)#channel-protocol pagp
DSL1(config-if-range)#channel-group 2 mode desirable
DSL1(config-if-range)#no shutdown

%LINK-5-CHANGED: Interface FastEthernet0/9, changed state to down

%LINK-5-CHANGED: Interface FastEthernet0/10, changed state to down
DSL1(config-if-range)#end
DSL1#
%SYS-5-CONFIG_I: Configured from console by console

DSL1#
```

### Switch DLS2

```
interface range f0/9-10
channel-protocol pagp
channel-group 2 mode desirable
no shutdown
end
```

Figura 52.interfaces F0/9 y fa0/10 DLS2

```
DSL2(config)#interface range f0/9-10
DSL2(config-if-range)#channel-protocol pagp
DSL2(config-if-range)#channel-group 2 mode desirable
DSL2(config-if-range)#no shutdown

%LINK-5-CHANGED: Interface FastEthernet0/9, changed state to down

%LINK-5-CHANGED: Interface FastEthernet0/10, changed state to down
DSL2(config-if-range)#end
DSL2#
%SYS-5-CONFIG_I: Configured from console by console

DSL2#
```

### Switch ALS1

```
interface range f0/9-10
channel-protocol pagp
channel-group 2 mode desirable
no shutdown
end
```

Figura 53.interfaces F0/9 y fa0/10 ALS1

```
ASL1(config)#interface range f0/9-10
ASL1(config-if-range)#channel-protocol pagp
ASL1(config-if-range)#channel-group 2 mode desirable
ASL1(config-if-range)#no shutdown
```

### Switch ALS2

```
interface range f0/9-10
channel-protocol pagp
channel-group 2 mode desirable
no shutdown
end
```

*Figura 54. interfaces F0/9 y fa0/10 ALS2*

```
ASL2(config)#interface range f0/9-10
ASL2(config-if-range)#channel-protocol pagp
ASL2(config-if-range)#channel-group 2 mode desirable
ASL2(config-if-range)#no shutdown
```

- 4) Todos los puertos troncales serán asignados a la VLAN 800 como la VLAN nativa.

### Switch DLS1

```
interface range f0/7-12
switchport trunk encapsulation dot1q
switchport trunk native vlan 800
switchport mode trunk
switchport nonegotiate
no shutdown
exit
```

*Figura 55. VLAN 800 DLS1*

```
DLS1(config)#interface range f0/7-12
DLS1(config-if-range)#switchport trunk encapsulation dot1q
DLS1(config-if-range)#switchport trunk native vlan 800
DLS1(config-if-range)#switchport mode trunk
DLS1(config-if-range)#switchport nonegotiate
DLS1(config-if-range)#no shutdown
```

### Switch DLS2

```
interface range f0/7-12
switchport trunk encapsulation dot1q
switchport trunk native vlan 800
switchport mode trunk
switchport nonegotiate
no shutdown
exit
```

*Figura 56.VLAN 800 DLS2*

```
DSL2(config)#int ran f0/7-12
DSL2(config-if-range)#switchport trunk encap dot1q
DSL2(config-if-range)#switchport trunk native vlan 800
DSL2(config-if-range)#switchport mode trunk
DSL2(config-if-range)#switchport nonegotiate
DSL2(config-if-range)#no shut
```

### Switch ALS1

```
intranf0/7-10
switchporttrunkencapdot1q
switchporttrunknativevlan800
switchportmodetrunk
switchportnonegotiate
noshut
exit
```

*Figura 57.VLAN 800 ASL1*

```
ASL1(config)#int ran f0/7-10
ASL1(config-if-range)#switchport trunk encap dot1q
^
% Invalid input detected at '^' marker.

ASL1(config-if-range)#switchport trunk native vlan 800
ASL1(config-if-range)#switchport mode trunk

ASL1(config-if-range)#switchport nonegotiate
ASL1(config-if-range)#no shut
ASL1(config-if-range)#exit
%LINEPROTO-5-UPDOWN: Line protocol on Interface FastEthernet0/7,
changed state to down
```

### Switch ALS2

```
intranf0/7-10
switchporttrunkencapdot1q
switchporttrunknativevlan800
switchportmodetrunk
switchportnonegotiate
noshut
exit
```

Figura 58.VLAN 800 ASL2

```
ASL2(config)#int ran f0/7-10
ASL2(config-if-range)#switchport trunk encap dot1q
^
% Invalid input detected at '^' marker.

ASL2(config-if-range)#switchport trunk native vlan 800
ASL2(config-if-range)#switchport mode trunk
ASL2(config-if-range)#switchport nonegotiate
ASL2(config-if-range)#no shut
ASL2(config-if-range)#exit
%LINEPROTO-5-UPDOWN: Line protocol on Interface FastEthernet0/7,
changed state to down

%LINEPROTO-5-UPDOWN: Line protocol on Interface FastEthernet0/7,
changed state to up

%LINEPROTO-5-UPDOWN: Line protocol on Interface FastEthernet0/8,
changed state to down
```

d. Configurar DLS1, ALS1, y ALS2 para utilizar VTP versión 3

1) Utilizar el nombre de dominio UNAD con la contraseña cisco123

Switch DLS1

```
conf t
vtp domain UNAD
vtp password cisco123
end
```

Figura 59.Confi Contraseña DLS1

```
DSL1(config)#vtp domain UNAD
Changing VTP domain name from NULL to UNAD
DSL1(config)#vtp password cisco123
Setting device VLAN database password to cisco123
DSL1(config)#end
DSL1#
%SYS-5-CONFIG_I: Configured from console by console

DSL1#|
```

2) Configurar DLS1 como servidor principal para las VLAN.

Switch DLS1

```
conf t
vtp version 2
```

```
vtpprimarymst
end
vtpprimarymst
```

*Figura 60.VTP Mode Server DSL1*

```
DSL1(config)#vtp version 2
VTP mode already in V2.
DSL1(config)#vtp mode server
Device mode already VTP SERVER.
DSL1(config)#
```

3) Configurar ALS1 y ALS2 como clientes VTP.

Switch ALS1

```
spanning-treemodempvst
vtpversion2
vtpmodeclient
end
```

*Figura 61.Clientes VTP ASL1*

```
ASL1(config)#spanning-tree mode pvst
ASL1(config)#vtp version 2
Cannot modify version in VTP client mode
ASL1(config)#vtp mode client
Device mode already VTP CLIENT.
ASL1(config)#
```

Switch ALS1

```
spanning-treemodemst
vtpversion3
vtpmodeclientmst
end
```

*Figura 62.Clientes VTP ASL2*

```
ASL2(config)#spanning-tree mode pvst
ASL2(config)#vtp version 2
VTP mode already in V2.
ASL2(config)#vtp mode client
Setting device to VTP CLIENT mode.
ASL2(config)#
```

e. Configurar en el servidor principal las siguientes VLAN:

Table 1. Interfaces Loopback para crear R1

Número de VLAN	Nombre de VLAN	Número de VLAN	Nombre de VLAN
800	NATIVA	434	ESTACIONAMIENTO
12	EJECUTIVOS	123	MANTENIMIENTO
234	HUESPEDES	1010	VOZ
1111	VIDEONET	3456	ADMINISTRACIÓN

```
Switch DLS1
vlan800
nameNATIVA
exit
vlan12
nameEJECUTIVOS
exit
vlan234
nameHUESPEDES
exit
vlan111
nameVIDEONET
exit
vlan123
nameMANTENIMIENTO
exit
vlan101
nameVOZ
exit
vlan345
nameADMINISTRACION
exit
```

Figura 63.Servidor VLAN DLS1

```
DSL1(config)#vlan 800
DSL1(config-vlan)#name NATIVA
DSL1(config-vlan)#exit
DSL1(config)#vlan 12
DSL1(config-vlan)#name EJECUTIVOS
DSL1(config-vlan)#exit
DSL1(config)#vlan 234
DSL1(config-vlan)#name HUESPEDES
DSL1(config-vlan)#exit
```

Switch DLS1

Figura 64.Servidor VLAN DLS2

```
DSL1(config-vlan)#name VIDEONET
DSL1(config-vlan)#exit
DSL1(config)#vlan 123
DSL1(config-vlan)#name MANTENIMIENTO
DSL1(config-vlan)#exit
DSL1(config)#vlan 101
DSL1(config-vlan)#name VOZ
DSL1(config-vlan)#exit
DSL1(config)#vlan 345
DSL1(config-vlan)#name ADMINISTRACION
DSL1(config-vlan)#exit
DSL1(config)#
```

- f. En DLS1, suspender la VLAN 434.

Switch DLS1

```
vlan434
nameESTACIONAMIENTO
statesuspend
exit
```

Figura 65.VLAN 434 DLS1

```
DSL1(config)#vlan 434
DSL1(config-vlan)#no remote-span
DSL1(config-vlan)#
```

- g. Configurar DLS2 en modo VTP transparente VTP utilizando VTP versión 2, y configurar en DLS2 las mismas VLAN que en DLS1.

Switch DLS2

```
vtpversion2
vtpmodetransparent
vlan800
nameNATIVA
```

```

exit
vlan12
nameEJECUTIVOS
exit
vlan234
nameHUESPEDES
exit
vlan1111
nameVIDEONET
exit
vlan123
nameMANTENIMIENTO
exit
vlan1010
nameVOZ
exit
vlan3456
nameADMINISTRACION
exit

```

*Figura 66.VLAN 434 DLS2*

```

DSL2(config)#vtp version 2
VTP mode already in V2.
DSL2(config)#vtp mode transparent
Setting device to VTP TRANSPARENT mode.
DSL2(config)#vlan 800
DSL2(config-vlan)#name NATIVA
DSL2(config-vlan)#exit
DSL2(config)#vlan 12
DSL2(config-vlan)#name EJECUTIVOS
DSL2(config-vlan)#exit
DSL2(config)#vlan 234
DSL2(config-vlan)#name HUESPEDES
DSL2(config-vlan)#exit
DSL2(config)#vlan 1111
DSL2(config-vlan)#name VIDEONET
DSL2(config-vlan)#exit
DSL2(config)#vlan 123
DSL2(config-vlan)#name MANTENIMIENTO
DSL2(config-vlan)#exit
DSL2(config)#vlan 1010
DSL2(config-vlan)#name VOZ
DSL2(config-vlan)#exit
DSL2(config)#vlan 3456
DSL2(config-vlan)#name ADMINISTRACION
DSL2(config-vlan)#exit
%LINK-5-CHANGED: Interface Vlan800, changed state to up

```

h. Suspende VLAN 434 en DLS2.

Switch DLS2

```
vlan434
nameESTACIONAMIENTO
statesuspend
exit
```

*Figura 67.VLAN 434 DLS2*

```
DSL2(config)#vlan 434
DSL2(config-vlan)#no remote-span
DSL2(config-vlan)#
```

- i. En DLS2, crear VLAN 567 con el nombre de CONTABILIDAD. La VLAN de CONTABILIDAD no podrá estar disponible en cualquier otro Switch de la red.

Switch DLS2

```
vlan567
private-vlanisolated
nameCONTABILIDAD
exit
```

*Figura 68.VLAN 567 DLS2*

```
DSL2(config-vlan)#vlan 567
DSL2(config-vlan)#name CONTABILIDAD
DSL2(config-vlan)#no remote-span
```

- j. Configurar DLS1 como Spanning tree root para las VLAN 1, 12, 434, 800, 1010, 1111 y 3456 y como raíz secundaria para las VLAN 123 y 234.

Switch DLS1

```
spanning-tree vlan 123 root primary
spanning-tree vlan 234 root primary
spanning-tree vlan 12 root secondary
spanning-tree vlan 434 root secondary
spanning-tree vlan 800 root secondary
spanning-tree vlan 1010 root secondary
spanning-tree vlan 1111 root secondary
spanning-tree vlan 3456 root secondary
```

*Figura 69.Spanning tree DLS1*

```
DSL1(config)#spanning-tree vlan 123 root primary
DSL1(config)#spanning-tree vlan 234 root primary
DSL1(config)#spanning-tree vlan 12 root secondary
DSL1(config)#spanning-tree vlan 434 root secondary
DSL1(config)#spanning-tree vlan 800 root secondary
DSL1(config)#spanning-tree vlan 1010 root secondary
DSL1(config)#spanning-tree vlan 1111 root secondary
DSL1(config)#spanning-tree vlan 3456 root secondary
DSL1(config)#
```

- k. Configurar DLS2 como Spanning tree root para las VLAN 123 y 234 y como una raíz secundaria para las VLAN 12, 434, 800, 1010, 1111 y 3456.

Switch DLS2

```
spanning-tree vlan 123 root primary
spanning-tree vlan 234 root primary
spanning-tree vlan 12 root secondary
spanning-tree vlan 434 root secondary
spanning-tree vlan 800 root secondary
spanning-tree vlan 1010 root secondary
spanning-tree vlan 1111 root secondary
spanning-tree vlan 3456 root secondary
```

*Figura 70. Spanning tree DLS2*

```
DSL2 (config)#spanning-tree vlan 123 root primary
DSL2 (config)#spanning-tree vlan 234 root primary
DSL2 (config)#spanning-tree vlan 12 root secondary
DSL2 (config)#spanning-tree vlan 434 root secondary
DSL2 (config)#spanning-tree vlan 800 root secondary
DSL2 (config)#spanning-tree vlan 1010 root secondary
DSL2 (config)#spanning-tree vlan 1111 root secondary
DSL2 (config)#spanning-tree vlan 3456 root secondary
```

- l. Configurar todos los puertos como troncales de tal forma que solamente las VLAN que se han creado se les permitirá circular a través de éstos puertos.

Switch DLS1

```
int ran f0/7-12
switchport trunk encap dot1q
switchport trunk native vlan 800
switchport mode trunk
exit
```

*Figura 71. troncales DLS1*

Figura 71.troncales DLS1

```
DSL1(config)#int ran f0/7-12
DSL1(config-if-range)#switchport trunk encap dot1q
DSL1(config-if-range)#switchport trunk native vlan 800
DSL1(config-if-range)#switchport mode trunk
DSL1(config-if-range)#exit
%EC-5-CANNOT_BUNDLE2: Fa0/7 is not compatible with Po2 and will be
suspended (native vlan of Fa0/7 is 800, Po2 id 1)

%EC-5-CANNOT_BUNDLE2: Fa0/8 is not compatible with Po2 and will be
suspended (native vlan of Fa0/8 is 800, Po2 id 1)

%EC-5-CANNOT_BUNDLE2: Fa0/9 is not compatible with Po2 and will be
suspended (native vlan of Fa0/9 is 800, Po2 id 1)

%EC-5-CANNOT_BUNDLE2: Fa0/10 is not compatible with Po2 and will be
suspended (native vlan of Fa0/10 is 800, Po2 id 1)

%EC-5-CANNOT_BUNDLE2: Fa0/11 is not compatible with Po2 and will be
suspended (native vlan of Fa0/11 is 800, Po2 id 1)
```

#### Switch DLS2

```
int ran f0/7-12
switchport trunk encap dot1q
switchport trunk native vlan 800
switchport mode trunk
exit
```

Figura 72.troncales DLS2

```
DSL2(config)#int ran f0/7-12
DSL2(config-if-range)#switchport trunk encap dot1q
DSL2(config-if-range)#switchport trunk native vlan 800
DSL2(config-if-range)#switchport mode trunk
DSL2(config-if-range)#exit
%LINEPROTO-5-UPDOWN: Line protocol on Interface FastEthernet0/7,
changed state to down

%EC-5-CANNOT_BUNDLE2: Fa0/7 is not compatible with Po2 and will be
suspended (native vlan of Fa0/7 is 800, Po2 id 1)

%LINEPROTO-5-UPDOWN: Line protocol on Interface FastEthernet0/8,
changed state to down

%EC-5-CANNOT_BUNDLE2: Fa0/8 is not compatible with Po2 and will be
suspended (native vlan of Fa0/8 is 800, Po2 id 1)

%EC-5-CANNOT_BUNDLE2: Fa0/9 is not compatible with Po2 and will be
suspended (native vlan of Fa0/9 is 800, Po2 id 1)

%LINEPROTO-5-UPDOWN: Line protocol on Interface FastEthernet0/9,
changed state to down

%EC-5-CANNOT_BUNDLE2: Fa0/10 is not compatible with Po2 and will be
suspended (native vlan of Fa0/10 is 800, Po2 id 1)

%LINEPROTO-5-UPDOWN: Line protocol on Interface FastEthernet0/10,
changed state to down

%LINEPROTO-5-UPDOWN: Line protocol on Interface FastEthernet0/11,
changed state to down

%EC-5-CANNOT_BUNDLE2: Fa0/11 is not compatible with Po2 and will be
```

### Switch ALS1

```
int ran f0/7-12
switchport trunk allowed vlan 800
switchport trunk native vlan 800
switchport mode trunk
exit
```

Figura 73.troncales ALS2

```
ASL1(config)#int ran f0/7-12
ASL1(config-if-range)#switchport trunk allowed vlan 800
ASL1(config-if-range)#switchport trunk native vlan 800
ASL1(config-if-range)#switchport mode trunk
ASL1(config-if-range)#exit
%LINEPROTO-5-UPDOWN: Line protocol on Interface FastEthernet0/7,
changed state to down

%LINEPROTO-5-UPDOWN: Line protocol on Interface FastEthernet0/7,
changed state to up

%LINEPROTO-5-UPDOWN: Line protocol on Interface FastEthernet0/7,
changed state to down

%LINEPROTO-5-UPDOWN: Line protocol on Interface FastEthernet0/7,
changed state to up

%LINEPROTO-5-UPDOWN: Line protocol on Interface FastEthernet0/8,
changed state to down

%LINEPROTO-5-UPDOWN: Line protocol on Interface FastEthernet0/8,
changed state to up

%LINEPROTO-5-UPDOWN: Line protocol on Interface FastEthernet0/8,
changed state to down
```

## Switch ALS2

```
intranf0/7-12
switchporttrunkencapdot1q
switchporttrunknativevlan800
switchportmodetrunk
exit
```

Figura 74.troncales ALS2

```
ASL2(config)#int ran f0/7-12
ASL2(config-if-range)#switchport trunk allowed vlan 800
ASL2(config-if-range)#switchport trunk native vlan 800
ASL2(config-if-range)#switchport mode trunk
ASL2(config-if-range)#exit
%LINEPROTO-5-UPDOWN: Line protocol on Interface FastEthernet0/7,
changed state to down

%LINEPROTO-5-UPDOWN: Line protocol on Interface FastEthernet0/7,
changed state to up

%LINEPROTO-5-UPDOWN: Line protocol on Interface FastEthernet0/7,
changed state to down

%LINEPROTO-5-UPDOWN: Line protocol on Interface FastEthernet0/7,
changed state to up
```

- m. Configurar las siguientes interfaces como puertos de acceso, asignados a las VLAN de la siguiente manera:

Table 2. Interfaces loopback para crear R2

Interfaz	DLS1	DLS2	ALS1	ALS2
<b>Interfaz Fa0/6</b>	3456	12 , 1010	123, 1010	234
<b>Interfaz Fa0/15</b>	1111	1111	1111	1111
<b>Interfaces F0 /16-18</b>		567		

### Switch DLS1

```
interface fastethernet0/6
switchport access vlan 3456
no sh
interface fastethernet0/15
switchport access vlan 111
no sh
end
```

Figura 75. Asignados a las VLAN DLS1

```
DSL1(config)#interface fastethernet0/6
DSL1(config-if)#switchport access vlan 3456
DSL1(config-if)#no sh
DSL1(config-if)#interface fastethernet0/15
DSL1(config-if)#switchport access vlan 111
DSL1(config-if)#no sh

%LINK-5-CHANGED: Interface FastEthernet0/15, changed state to down
DSL1(config-if)#end
```

### Switch DLS2

```
interface fastethernet0/6
switchport access vlan 12
switchport access vlan 1010
no sh
interface fastethernet0/15
switchport access vlan 111
no sh
int ran f0/16-18
switchport access vlan 567
no sh
end
```

Figura 76. Asignados a las VLAN DLS2

```
DSL2(config)#interface fastethernet0/6
DSL2(config-if)#switchport access vlan 12
DSL2(config-if)#switchport access vlan 1010
DSL2(config-if)#no sh

DSL2(config-if)#interface fastethernet0/15
DSL2(config-if)#switchport access vlan 111
% Access VLAN does not exist. Creating vlan 111
DSL2(config-if)#no sh

%LINK-5-CHANGED: Interface FastEthernet0/15, changed state to down
DSL2(config-if)#int ran f0/16-18
DSL2(config-if-range)#switchport access vlan 567
DSL2(config-if-range)#no sh

%LINK-5-CHANGED: Interface FastEthernet0/16, changed state to down

%LINK-5-CHANGED: Interface FastEthernet0/17, changed state to down
```

## Switch ALS1

```
interface fastethernet0/6
switchport access vlan 123
switchport access vlan 101
no sh
interface fastethernet0/15
switchport access vlan 111
no sh
end
```

Figura 77. Asignados a las VLAN ALS1

```
ASL1(config)#interface fastethernet0/6
ASL1(config-if)#switchport access vlan 123
ASL1(config-if)#switchport access vlan 101
ASL1(config-if)#no sh

ASL1(config-if)#interface fastethernet0/15
ASL1(config-if)#switchport access vlan 111
ASL1(config-if)#no sh

%LINK-5-CHANGED: Interface FastEthernet0/15, changed state to down
ASL1(config-if)#end
%LINK-5-CHANGED: Interface FastEthernet0/6, changed state to up

%LINEPROTO-5-UPDOWN: Line protocol on Interface FastEthernet0/6,
changed state to up

ASL1(config-if)#end|
```

## Switch ALS2

```
interface fastethernet0/6
switchport access vlan 234
no sh
interface fastethernet0/15
switchport access vlan 111
no sh
end
```

Figura 78. Asignados a las VLAN ASL2

```
ASL2(config)#interface fastethernet0/6
ASL2(config-if)#switchport access vlan 234
ASL2(config-if)#no sh

ASL2(config-if)#interface fastethernet0/15
ASL2(config-if)#switchport access vlan 111
ASL2(config-if)#no sh

%LINK-5-CHANGED: Interface FastEthernet0/15, changed state to down
ASL2(config-if)#end
%LINK-5-CHANGED: Interface FastEthernet0/6, changed state to up

%LINEPROTO-5-UPDOWN: Line protocol on Interface FastEthernet0/6,
changed state to up

ASL2(config-if)#end
```

## Part 2: conectividad de red de prueba y las opciones configuradas.

- a. Verificar la existencia de las VLAN correctas en todos los switches y la asignación de puertos troncales y de acceso

show vlan brief

Figura 79. show vlan DSL1

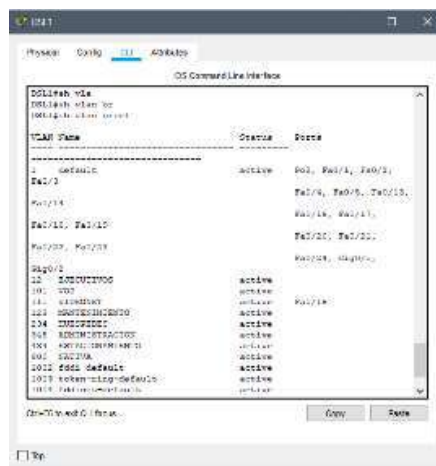

VLAN Name	Status	Ports
-----	-----	-----
default	active	Fa0/1, Fa0/2, Fa0/3
FastEthernet0/3		FastEthernet0/3
FastEthernet0/15		FastEthernet0/15
FastEthernet0/6		FastEthernet0/6
FastEthernet0/1		FastEthernet0/1
FastEthernet0/2		FastEthernet0/2
FastEthernet0/4		FastEthernet0/4
FastEthernet0/5		FastEthernet0/5
FastEthernet0/7		FastEthernet0/7
FastEthernet0/8		FastEthernet0/8
FastEthernet0/9		FastEthernet0/9
FastEthernet0/10		FastEthernet0/10
FastEthernet0/11		FastEthernet0/11
FastEthernet0/12		FastEthernet0/12
FastEthernet0/13		FastEthernet0/13
FastEthernet0/14		FastEthernet0/14
FastEthernet0/16		FastEthernet0/16
FastEthernet0/17		FastEthernet0/17
FastEthernet0/18		FastEthernet0/18
FastEthernet0/19		FastEthernet0/19
FastEthernet0/20		FastEthernet0/20
FastEthernet0/21		FastEthernet0/21
FastEthernet0/22		FastEthernet0/22
FastEthernet0/23		FastEthernet0/23
FastEthernet0/24		FastEthernet0/24
FastEthernet0/25		FastEthernet0/25
FastEthernet0/26		FastEthernet0/26
FastEthernet0/27		FastEthernet0/27
FastEthernet0/28		FastEthernet0/28
FastEthernet0/29		FastEthernet0/29
FastEthernet0/30		FastEthernet0/30
FastEthernet0/31		FastEthernet0/31
FastEthernet0/32		FastEthernet0/32
FastEthernet0/33		FastEthernet0/33
FastEthernet0/34		FastEthernet0/34
FastEthernet0/35		FastEthernet0/35
FastEthernet0/36		FastEthernet0/36
FastEthernet0/37		FastEthernet0/37
FastEthernet0/38		FastEthernet0/38
FastEthernet0/39		FastEthernet0/39
FastEthernet0/40		FastEthernet0/40
FastEthernet0/41		FastEthernet0/41
FastEthernet0/42		FastEthernet0/42
FastEthernet0/43		FastEthernet0/43
FastEthernet0/44		FastEthernet0/44
FastEthernet0/45		FastEthernet0/45
FastEthernet0/46		FastEthernet0/46
FastEthernet0/47		FastEthernet0/47
FastEthernet0/48		FastEthernet0/48
FastEthernet0/49		FastEthernet0/49
FastEthernet0/50		FastEthernet0/50
FastEthernet0/51		FastEthernet0/51
FastEthernet0/52		FastEthernet0/52
FastEthernet0/53		FastEthernet0/53
FastEthernet0/54		FastEthernet0/54
FastEthernet0/55		FastEthernet0/55
FastEthernet0/56		FastEthernet0/56
FastEthernet0/57		FastEthernet0/57
FastEthernet0/58		FastEthernet0/58
FastEthernet0/59		FastEthernet0/59
FastEthernet0/60		FastEthernet0/60
FastEthernet0/61		FastEthernet0/61
FastEthernet0/62		FastEthernet0/62
FastEthernet0/63		FastEthernet0/63
FastEthernet0/64		FastEthernet0/64
FastEthernet0/65		FastEthernet0/65
FastEthernet0/66		FastEthernet0/66
FastEthernet0/67		FastEthernet0/67
FastEthernet0/68		FastEthernet0/68
FastEthernet0/69		FastEthernet0/69
FastEthernet0/70		FastEthernet0/70
FastEthernet0/71		FastEthernet0/71
FastEthernet0/72		FastEthernet0/72
FastEthernet0/73		FastEthernet0/73
FastEthernet0/74		FastEthernet0/74
FastEthernet0/75		FastEthernet0/75
FastEthernet0/76		FastEthernet0/76
FastEthernet0/77		FastEthernet0/77
FastEthernet0/78		FastEthernet0/78
FastEthernet0/79		FastEthernet0/79
FastEthernet0/80		FastEthernet0/80
FastEthernet0/81		FastEthernet0/81
FastEthernet0/82		FastEthernet0/82
FastEthernet0/83		FastEthernet0/83
FastEthernet0/84		FastEthernet0/84
FastEthernet0/85		FastEthernet0/85
FastEthernet0/86		FastEthernet0/86
FastEthernet0/87		FastEthernet0/87
FastEthernet0/88		FastEthernet0/88
FastEthernet0/89		FastEthernet0/89
FastEthernet0/90		FastEthernet0/90
FastEthernet0/91		FastEthernet0/91
FastEthernet0/92		FastEthernet0/92
FastEthernet0/93		FastEthernet0/93
FastEthernet0/94		FastEthernet0/94
FastEthernet0/95		FastEthernet0/95
FastEthernet0/96		FastEthernet0/96
FastEthernet0/97		FastEthernet0/97
FastEthernet0/98		FastEthernet0/98
FastEthernet0/99		FastEthernet0/99
FastEthernet0/100		FastEthernet0/100







## CONCLUSIONES

HRSP es un protocolo propiedad de CISCO que permite crear routers redundantes y validar el estado de los routers para el envío, por cuanto contribuye a la fidelidad y disponibilidad de la red, esto teniendo en cuenta que el camino de información no se ve interrumpido pues esta puede encontrar otra ruta para llegar a su destino.

EIGRP es un protocolo de enrutamiento propiedad de CISCO, permite configurar redes libres de bucles, realizar convergencia rápida, entre otras, además de soportar diferentes dispositivos mediante una configuración sencilla y utilizando ancho de banda reducido.

OSPFv3 es un protocolo de enrutamiento que entre otras cosas permite subdividir la red en áreas, una de sus ventajas es la actualización automática de las tablas de enrutamiento, actualmente cuenta con tres versiones, siendo la tercera que permite la inclusión de IPv6.

VTP es un protocolo propietario de Cisco el cual contribuye con la administración de la red, entre otras cosas permite distribuir una VLAN a toda la red sin que sea necesario realizar la configuración de esta en cada uno de los dispositivos, la versión más reciente es la 3 la cual solo está disponible en Catalyst IOS.

Mediante las VLAN (Red de área local virtual) se crean redes independientes, las cuales no son físicas por cuanto no involucran un ajuste del cableado estructurado, sino que se realizan de manera lógica en el dispositivo, permiten disminuir el tamaño del dominio de difusión y contribuyen con la administración de la red pues su objetivo es crear secciones pequeñas, permitiendo enviar información o actualizaciones a un segmento en particular.

Un enlace punto a punto entre dos dispositivos de red, es un enlace troncal que puede transportar más de una VLAN sin que llegue a pertenecer a una VLAN específica, los switch cisco admiten IEEE 802.1Q que facilitan la coordinación de estos enlaces

Las VLAN pueden dividirse en dos, las VLAN estáticas que cuentan con un puerto asociado y las dinámicas, las cuales desarrollan su propia configuración.

Se pudo validar experimentalmente que al realizar la configuración del protocolo PAGP, son funcionales los modos disarable-disarable, auto-disarable, sin embargo se genera error al configurar ambos switch en modo auto, en cuanto LACP es funcional activoactivo, activo-pasivo, pero al configurarse ambos switch de forma pasiva se genera error.

## BIBLIOGRAFÍA

- Teare, D., Vachon B., Graziani, R. (2015). CISCO Press (Ed). Basic Network and Routing Concepts.  
Implementing Cisco IP Routing (ROUTE) Foundation Learning Guide CCNP ROUTE 300-101.  
Recuperado de <https://1drv.ms/b/s!AmlJYei-NT1lInMfy2rhPZHwEoWx>
- Teare, D., Vachon B., Graziani, R. (2015). CISCO Press (Ed). EIGRP Implementation.  
Implementing Cisco IP Routing (ROUTE) Foundation Learning Guide CCNP ROUTE 300-101. Recuperado de <https://1drv.ms/b/s!AmlJYei-NT1lInMfy2rhPZHwEoWx>
- Teare, D., Vachon B., Graziani, R. (2015). CISCO Press (Ed). OSPF Implementation. Implementing Cisco  
IP Routing (ROUTE) Foundation Learning Guide CCNP ROUTE 300-101.  
Recuperado de <https://1drv.ms/b/s!AmlJYei-NT1lInMfy2rhPZHwEoWx>
- Teare, D., Vachon B., Graziani, R. (2015). CISCO Press (Ed). Manipulating Routing Updates.  
Implementing Cisco IP Routing (ROUTE) Foundation Learning Guide CCNP ROUTE 300-101.  
Recuperado de <https://1drv.ms/b/s!AmlJYei-NT1lInMfy2rhPZHwEoWx>
- Teare, D., Vachon B., Graziani, R. (2015). CISCO Press (Ed). Path Control Implementation.  
Implementing Cisco IP Routing (ROUTE) Foundation Learning Guide CCNP ROUTE 300-101.  
Recuperado de <https://1drv.ms/b/s!AmlJYei-NT1lInMfy2rhPZHwEoWx>
- Teare, D., Vachon B., Graziani, R. (2015). CISCO Press (Ed). Implementing a Border Gateway Protocol (BGP) Solution for ISP Connectivity. Implementing Cisco IP Routing (ROUTE) Foundation Learning  
Guide CCNP ROUTE 300-101. Recuperado de <https://1drv.ms/b/s!AmlJYei-NT1lInMfy2rhPZHwEoWx>
- Teare, D., Vachon B., Graziani, R. (2015). CISCO Press (Ed). Implementing Routing Facilities for Branch  
Offices and Mobile Workers. Implementing Cisco IP Routing (ROUTE) Foundation Learning  
Guide  
CCNP ROUTE 300-101. Recuperado de <https://1drv.ms/b/s!AmlJYei-NT1lInMfy2rhPZHwEoWx>
- Teare, D., Vachon B., Graziani, R. (2015). CISCO Press (Ed). Implementing IPv6 in the Enterprise  
Network. Implementing Cisco IP Routing (ROUTE) Foundation Learning Guide CCNP ROUTE  
300-  
101. Recuperado de <https://1drv.ms/b/s!AmlJYei-NT1lInMfy2rhPZHwEoWx>
- Froom, R., Frahim, E. (2015). CISCO Press (Ed). Fundamentals Review. Implementing Cisco IP  
Switched  
Networks (SWITCH) Foundation Learning Guide CCNP SWITCH 300-115. Recuperado  
de <https://1drv.ms/b/s!AmlJYei-NT1lInWR0hoMxgBNv1CJ>

Froom, R., Frahim, E. (2015). CISCO Press (Ed). Campus Network Design Fundamentals. Implementing Cisco IP Switched Networks (SWITCH) Foundation Learning Guide CCNP SWITCH 300-115.

Recuperado de <https://1drv.ms/b/s!AmIJYei-NT1IlnWR0hoMxgBNv1CJ>

Froom, R., Frahim, E. (2015). CISCO Press (Ed). Spanning Tree Implementation. Implementing Cisco IP Switched Networks (SWITCH) Foundation Learning Guide CCNP SWITCH 300-115.

Recuperado de <https://1drv.ms/b/s!AmIJYei-NT1IlnWR0hoMxgBNv1CJ>

Froom, R., Frahim, E. (2015). CISCO Press (Ed). InterVLAN Routing. Implementing Cisco IP Switched

Networks (SWITCH) Foundation Learning Guide CCNP SWITCH 300-115. Recuperado de <https://1drv.ms/b/s!AmIJYei-NT1IlnWR0hoMxgBNv1CJ>

Froom, R., Frahim, E. (2015). CISCO Press (Ed). First Hop Redundancy Protocols. Implementing Cisco IP Switched Networks (SWITCH) Foundation Learning Guide CCNP SWITCH 300-115.

Recuperado de <https://1drv.ms/b/s!AmIJYei-NT1IlnWR0hoMxgBNv1CJ>

Froom, R., Frahim, E. (2015). CISCO Press (Ed). Network Management. Implementing Cisco IP Switched

Networks (SWITCH) Foundation Learning Guide CCNP SWITCH 300-115.

Recuperado de <https://1drv.ms/b/s!AmIJYei-NT1IlnWR0hoMxgBNv1CJ>

Froom, R., Frahim, E. (2015). CISCO Press (Ed). Switching Features and Technologies. Implementing Cisco IP Switched Networks (SWITCH) Foundation Learning Guide CCNP SWITCH 300-115.

Recuperado de <https://1drv.ms/b/s!AmIJYei-NT1IlnWR0hoMxgBNv1CJ>

Normas Icontec 2018 para trabajos escritos | mundonets. (2018). Recuperado de

<https://www.mundonets.com/normas-icontec/>

Normas ICONTEC 2016 para crear trabajos escritos - Tutorial. (2018). Recuperado de

<https://colombiaconsulta.com/normas-icontec/>