

Evaluación – Prueba de habilidades prácticas CCNA

Jhon Alexander Cuervo Barragan

UNIVERSIDAD NACIONAL ABIERTA Y A DISTANCIA
UNAD
ESCUELA DE CIENCIAS BÁSICAS TECNOLOGÍA E INGENIERÍA
DIPLOMADO DE PROFUNDIZACION CISCO
YOPAL
2019



Evaluación – Prueba de habilidades prácticas CCNA

Jhon Alexander Cuervo Barragan

TRABAJO DE PROFUNDIZACION EN COMUNICACIONES CISCO

DIEGO EDINSON RAMIREZ
Ingeniero Electrónico

UNIVERSIDAD NACIONAL ABIERTA Y A DISTANCIA
UNAD
ESCUELA DE CIENCIAS BÁSICAS TECNOLOGÍA E INGENIERÍA
DIPLOMADO DE PROFUNDIZACION CISCO
YOPAL
2019



Nota de Aceptación

Presidente del Jurado

Jurado

Jurado

Yopal 15/12/2019

DEDICATORIA

Dedico este trabajo a mi familia quien me apoyo en todo mi proceso formativo y a cada una de las personas que me brindaron su apoyo y conocimiento para afrontar esta carrera con gran determinación y compromiso.

AGRADECIMIENTOS

Expreso mi total agradecimiento a todos mis familiares quienes siempre me apoyaron en este proceso muy especialmente a mi señora esposa e hijos a quienes en ocasiones tuve que quitar de su tiempo para poder cumplir con mis compromisos estudiantiles, de igual manera doy un agradecimiento muy especial la directora de ECBTI de la ciudad de Yopal Ingeniera Adriana del Pilar Noguera por su gran entrega dedicación y vocación para la enseñanza.

CONTENIDO

	Pág.
1. INTRODUCCIÓN	8
2. OBJETIVOS	9
2.1 OBJETIVO GENERAL	9
2.2 OBJETIVOS ESPECÍFICOS	9
3 PLANTEAMIENTO DEL PROBLEMA	10
3.1 DEFINICIÓN DEL PROBLEMA	10
DESARROLLO DE LOS EJERCICIOS PROPUESTOS	11
ESCENARIO 1	11
Parte 2: Configuración Básica	14
Parte 3: Configuración de Enrutamiento	21
Parte 4: Configuración de las listas de Control de Acceso	31
Parte 5: Comprobación de la red instalada	35
ESCENARIO 2	41
1. Todos los routers deben tener las siguientes configuraciones básicas	43
2. El DHCP deberá proporcionar solo direcciones a los hosts de BUCARAMANGA y CUNDINAMARCA	59
3. El web server deberá tener NAT estático y el resto de los equipos de la topología emplearan NAT de sobrecarga (PAT)	62
4. El enrutamiento deberá tener autenticación	67
5. Listas de control de acceso	68
CONCLUSIONES	78
BIBLIOGRAFÍA	79

GLOSARIO

VLAN: Las **VLAN** o Red de Área Local Virtual, son una tecnología a nivel de capa 2 del modelo de referencia OSI que ayuda a optimizar, proteger y segmentar el tráfico de la red

SWITCH: Conmutador o switch. Dispositivo digital de lógica de interconexión de redes de computadores que opera en la capa 2 (nivel de enlace de datos) del modelo OSI. Su función es interconectar dos o más segmentos de red, de manera similar a los Puentes (bridges), pasando datos de un segmento a otro de acuerdo con la dirección MAC de destino de las tramas en la red.

ROUTER: Router. Es un Dispositivo de interconexión de redes informáticas que permite asegurar el enrutamiento de paquetes entre redes o determinar la ruta que debe tomar el paquete de datos.

1. INTRODUCCIÓN

En este trabajo encontramos la construcción de una red de una empresa la cual se interconecta de distintas ciudades como Bogotá, Medellín y Cali, con una topología sugerida por la guía de actividades y unas direcciones específicas para algunos equipos, en la cual se deben de poner en práctica los conocimientos adquiridos durante el diplomado de profundización en comunicaciones cisco, como lo son las configuraciones básicas de los equipos, configuración de enrutamientos, listas de control de acceso y la comprobación del funcionamiento mediante pruebas de comunicación como el comando ping.

Por otro lado, contamos con otro ejercicio de igual manera con varias sedes las cuales nos solicitan crear varias redes VLAN que se utilizan para ayudar a optimizar la red, proteger o segmentar la red.

Las VLAN se usan en ambientes, normalmente, empresariales que requieren asegurar segmentos de redes dentro de la misma infraestructura de red



2. OBJETIVOS

2.1 OBJETIVO GENERAL

Desarrollar la actividad denominado Prueba de habilidades prácticas CCNA, la cual consiste en realizar una interconexión de las ciudades de Bogotá, Medellín y Bucaramanga.

2.2 OBJETIVOS ESPECÍFICOS

Cumplir a cabalidad con la topología propuesta en la guía para el desarrollo de la actividad.

Realizar el direccionamiento IP de cada uno de los equipos que conforman la red.

Establecer y probar comunicación mediante los comandos PING



3 PLANTEAMIENTO DEL PROBLEMA

3.1 DEFINICIÓN DEL PROBLEMA

Una empresa de Tecnología posee tres sucursales distribuidas en las ciudades de Bogotá, Medellín y Cali, en donde el estudiante será el administrador de la red, el cual deberá configurar e interconectar entre sí cada uno de los dispositivos que forman parte del escenario, acorde con los lineamientos establecidos para el direccionamiento IP, protocolos de enrutamiento y demás aspectos que forman parte de la topología de red.

DESARROLLO DE LOS EJERCICIOS PROPUESTOS

ESCENARIO 1

Como trabajo inicial se debe realizar lo siguiente.

- Realizar las rutinas de diagnóstico y dejar los equipos listos para su configuración (asignar nombres de equipos, asignar claves de seguridad, etc).

ROUTER BOGOTA

```
Router(config)#hostname BOGOTA
BOGOTA(config)#no ip domain-lookup
BOGOTA(config)#service password-encryption
BOGOTA(config)#banner motd $!! SOLO PERSONAL DE LA EMPRESA - ACCESO DENEGADO;i;$
```

Configuramos las contraseñas:

```
BOGOTA(config)#enable secret class1
BOGOTA(config)#line console 0
BOGOTA(config-line)#password cisco1
BOGOTA(config-line)#login
BOGOTA(config-line)#line vty 0 15
BOGOTA(config-line)#password cisco1
BOGOTA(config-line)#login
```

ROUTER MEDELLIN

```
Router(config)#hostname MEDELLIN
MEDELLIN(config)#no ip domain-lookup
MEDELLIN(config)#service password-encryption
MEDELLIN(config)#banner motd $!! SOLO PERSONAL DE LA EMPRESA - ACCESO DENEGADO;i;$
```

Configuramos las contraseñas

```
MEDELLIN(config)#enable secret class1
MEDELLIN(config)#line console 0
MEDELLIN(config-line)#password cisco1
MEDELLIN(config-line)#login
MEDELLIN(config-line)#line vty 0 15
```

```
MEDELLIN(config-line)#password cisco1
MEDELLIN(config-line)#login
```

ROUTER CALI

```
Router(config)#hostname CALI
CALI(config)#no ip domain-lookup
CALI(config)#service password-encryption
CALI(config)#banner motd $!! SOLO PERSONAL DE LA EMPRESA - ACCESO DENEGADO;;$
```

Configuramos las contraseñas

```
CALI(config)#enable secret class1
CALI(config)#line console 0
CALI(config-line)#password cisco1
CALI(config-line)#login
CALI(config-line)#line vty 0 15
CALI(config-line)#password cisco1
CALI(config-line)#login
```

Procedemos hacer el proceso con los SWITCH

SWITCH BOGOTA

```
Switch(config)#hostname switchbogota
switchbogota(config)#no ip domain-lookup
switchbogota(config)#service password-encryption
switchbogota(config)#banner motd $!! SOLO PERSONAL DE LA EMPRESA - ACCESO DENEGADO;;$
switchbogota(config)#enable secret class1
switchbogota(config)#line console 0
switchbogota(config-line)#password cisco1
switchbogota(config-line)#login
switchbogota(config-line)#line vty 0 15
switchbogota(config-line)#password cisco1
switchbogota(config-line)#login
```

SWITCH MEDELLIN

```
Switch#conf term
switchmedellin(config)#hostname switchmedellin
switchmedellin(config)#no ip domain-lookup
switchmedellin(config)#service password-encryption
```

```
switchmedellin(config)#banner motd $!! SOLO PERSONAL DE LA EMPRESA - ACCESO DENEGADO;;$
```

- Configuramos las Contraseñas

```
switchmedellin(config)#enable secret class1
switchmedellin(config)#line console 0
switchmedellin(config-line)#password cisco1
switchmedellin(config-line)#login
switchmedellin(config-line)#line vty 0 15
switchmedellin(config-line)#password cisco1
switchmedellin(config-line)#login
```

SWITCH CALI

```
Switch(config)#hostname switchcali
switchcali(config)#no ip domain-lookup
switchcali(config)#service password-encryption
switchcali(config)#banner motd $!! SOLO PERSONAL DE LA EMPRESA - ACCESO DENEGADO;;$
```

- Configuramos las contraseñas

```
switchcali(config)#enable secret class1
switchcali(config)#line console 0
switchcali(config-line)#password cisco1
switchcali(config-line)#login
switchcali(config-line)#line vty 0 15
switchcali(config-line)#password cisco1
switchcali(config-line)#login
switchcali(config-line)#
```

Configurar la topología de red, de acuerdo con las siguientes especificaciones

Parte 1: Asignación de direcciones IP:

- a. Se debe dividir (subnetear) la red creando una segmentación en ocho partes, para permitir crecimiento futuro de la red corporativa.

- BOGOTA-LAN 192.168.1.0/27
- Medellín-LAN 192.168.1.32/27
- CALI-LAN 192.168.1.64/27
- BOGOTA-Medellín 192.168.1.96/27
- BOGOTA-CALI 192.168.1.128/27
- Disponible 192.168.1.160/27
- Disponible 192.168.1.192/27
- Disponible 192.168.1.224/27

b. Asignar una dirección IP a la red.

Parte 2: Configuración Básica.

a. Completar la siguiente tabla con la configuración básica de los routers, teniendo en cuenta las subredes diseñadas.

	R1	R2	R3
Nombre de Host	MEDELLIN	BOGOTA	CALI
Dirección de Ip en interfaz Serial 0/0	192.168.1.99	192.168.1.98	192.168.1.231
Dirección de Ip en interfaz Serial 0/1		192.168.1.130	
Dirección de Ip en interfaz FA 0/0	192.168.1.33	192.168.1.1	192.168.1.65
Protocolo de enrutamiento	Eigrp	Eigrp	Eigrp
Sistema Autónomo	200	200	200
Afirmaciones de red	192.168.1.0	192.168.1.0	192.168.1.0

Según la tabla de enrutamiento procedemos a configurar cada una de las interfaces:

MEDELLIN	interface serial 0/0	192.168.1.99	255.255.255.224
	interface fa 0/0	192.168.1.33	255.255.255.224
BOGOTA	interface serial 0/0	192.168.1.98	255.255.255.224
	interface serial 0/1	192.168.1.130	255.255.255.224
	interface fa 0/0	192.168.1.1	255.255.255.224
CALI	interface serial 0/0	192.168.1.131	255.255.255.224
	interface fa 0/0	192.168.1.65	255.255.255.224

De una vez configuramos las PC:

MEDELLIN	PC12	192.168.1.34	255.255.255.224	192.168.1.33
MEDELLIN	PC14	192.168.1.35	255.255.255.224	192.168.1.33
CALI	PC10	192.168.1.66	255.255.255.224	192.168.1.65
CALI	PC13	192.168.1.67	255.255.255.224	192.168.1.65
BOGOTA	WS-1	192.168.1.2	255.255.255.224	192.168.1.1
BOGOTA	SERVER	192.168.1.30	255.255.255.224	192.168.1.1

Configuración Interfaces Router Bogotá.

BOGOTA(config)#int s0/0/0

BOGOTA(config-if)#ip address 192.168.1.98 255.255.255.224

BOGOTA(config-if)#no shutdown

BOGOTA(config-if)#int s0/0/1

BOGOTA(config-if)#ip address 192.168.1.130 255.255.255.224

BOGOTA(config-if)#no shutdown

BOGOTA(config-if)#int f0/0

BOGOTA(config-if)#ip address 192.168.1.1 255.255.255.224

BOGOTA(config-if)#no shutdown

Configuración Interfaces Router Medellín.

MEDELLIN(config)#int s0/0/0

MEDELLIN(config-if)#ip address 192.168.1.99 255.255.255.224

MEDELLIN(config-if)#no shutdown

MEDELLIN(config-if)#int f0/0

MEDELLIN(config-if)#ip address 192.168.1.33 255.255.255.224

MEDELLIN(config-if)#no shutdown

Configuración Interfaces Router CALI.

CALI(config)#int s0/0/0

CALI(config-if)#ip address 192.168.1.231 255.255.255.224

CALI(config-if)#no shutdown

CALI(config-if)#int f0/0

CALI(config-if)#ip address 192.168.1.65 255.255.255.224

CALI(config-if)#no shutdown

Procedemos a verificar la configuración ingresada en cada una de las interfaces del router:

MEDELLIN>

MEDELLIN>enable

MEDELLIN#show ip interface brief

Interface IP-Address OK? Method Status Protocol

FastEthernet0/0 192.168.1.33 YES manual up up

FastEthernet0/1 unassigned YES NVRAM administratively down down

```
Serial0/0/0 192.168.1.99 YES manual up up
Serial0/0/1 unassigned YES NVRAM administratively down down
Vlan1 unassigned YES unset administratively down down
MEDELLIN#
```

bogota#

bogota#show ip interface brief

Interface IP-Address OK? Method Status Protocol

FastEthernet0/0 192.168.1.1 YES manual up up

FastEthernet0/1 unassigned YES NVRAM administratively down down

Serial0/0/0 192.168.1.98 YES manual up up

Serial0/0/1 192.168.1.130 YES manual up up

Vlan1 unassigned YES unset administratively down down

bogota#

cali#

cali#show ip interface brief

Interface IP-Address OK? Method Status Protocol

FastEthernet0/0 192.168.1.65 YES manual up up

FastEthernet0/1 unassigned YES NVRAM administratively down down

Serial0/0/0 192.168.1.131 YES manual up up

Serial0/0/1 unassigned YES NVRAM administratively down down

Vlan1 unassigned YES unset administratively down down

cali#

The diagram shows a network topology with three routers: 1841 Cali, 1841 Bogotá, and 1841 Medellín. The Medellín router is highlighted in red. A CLI window for the Medellín router shows the following configuration:

```

class1
cisco1
ACL 151

192.168.1.2/27
PC-PT WS-1
2960-24TT Switch1
interface fa 0/0
192.168.1.1 / 27

192.168.1.30/27
Medellin

interface s 0/0
192.168.1.98 / 27
interface s 0/1
192.168.1.130 / 27

192.168.1.34/27
PC-PT PC12
192.168.1.35/27
PC-PT PC14
2960-24TT Switch0
interface fa 0/0
192.168.1.33 / 27
1841 Medellin

interface se 0/0
192.168.1.99 / 27
interface se 0/1
192.168.1.130 / 27
1841 Cali

```

The CLI window shows the following output for the 'show ip interface brief' command:

```

MEDELLIN>enable
MEDELLIN#show ip interface brief
Interface      IP-Address      OK? Method Status      Protocol
FastEthernet0/0 192.168.1.33    YES manual up          up
FastEthernet0/1 unassigned      YES NVRAM  administratively down down
Serial0/0/0     192.168.1.99   YES manual up          up
Serial0/0/1     unassigned      YES NVRAM  administratively down down
Vlan1           unassigned      YES unset  administratively down down

MEDELLIN#
MEDELLIN#show ip interface brief
Interface      IP-Address      OK? Method Status      Protocol
FastEthernet0/0 192.168.1.33    YES manual up          up
FastEthernet0/1 unassigned      YES NVRAM  administratively down down
Serial0/0/0     192.168.1.99   YES manual up          up
Serial0/0/1     unassigned      YES NVRAM  administratively down down
Vlan1           unassigned      YES unset  administratively down down

MEDELLIN#!

```

The diagram shows the same network topology as above, but with the Bogotá router highlighted in red. A CLI window for the Bogotá router shows the following configuration:

```

192.168.1.2/27
PC-PT WS-1
192.168.1.1
Server-PT Server0
2960-24TT Switch1

interface s 0/0
192.168.1.98 - 255.255.255.224
interface s 0/1
192.168.1.130 - 255.255.255.224
interface fa 0/0
192.168.1.1 - 255.255.255.224

1841 Bogota

192.168.1.34/27
PC-PT PC12
192.168.1.35/27
PC-PT PC14
2960-24TT Switch0
interface fa 0/0
192.168.1.33 / 27
1841 Medellin

interface s 0/0
192.168.1.99 - 255.255.255.224
interface fa 0/0
192.168.1.33 - 255.255.255.224

```

The CLI window shows the following output for the 'show ip interface brief' command:

```

bogota>enable
bogota#show ip interface brief
Interface      IP-Address      OK? Method Status      Protocol
FastEthernet0/0 192.168.1.1     YES manual up          up
FastEthernet0/1 unassigned      YES NVRAM  administratively down down
Serial0/0/0     192.168.1.98   YES manual up          up
Serial0/0/1     192.168.1.130  YES manual up          up
Vlan1           unassigned      YES unset  administratively down down

bogota#
bogota#show ip interface brief
Interface      IP-Address      OK? Method Status      Protocol
FastEthernet0/0 192.168.1.1     YES manual up          up
FastEthernet0/1 unassigned      YES NVRAM  administratively down down
Serial0/0/0     192.168.1.98   YES manual up          up
Serial0/0/1     192.168.1.130  YES manual up          up
Vlan1           unassigned      YES unset  administratively down down

bogota#
bogota# !

```

class1
cisco1
ACL 151

192.168.1.2/27
PC-PT WS-1

192.168.1.34/27
PC-PT PC12

192.168.1.35/27
PC-PT PC14

2960-24TT Switch0

interface fa 0/0
192.168.1.33 / 27

184 Medelli

192.168.1.30/27

Cali

Physical Config CLI Attributes

IOS Command Line Interface

```
%LINEPROTO-5-UPDOWN: Line protocol on Interface Serial0/0/0, changed state to up
El Acceso no autorizado est prohibido

cali>enable
cali#show ip interface brief
Interface          IP-Address      OK? Method Status      Protocol
FastEthernet0/0    192.168.1.65    YES manual up          up
FastEthernet0/1    unassigned      YES NVRAM  administratively down down
Serial0/0/0        192.168.1.131  YES manual up          up
Serial0/0/1        unassigned      YES NVRAM  administratively down down
Vlan1              unassigned      YES unset  administratively down down
cali#
cali#show ip interface brief
Interface          IP-Address      OK? Method Status      Protocol
FastEthernet0/0    192.168.1.65    YES manual up          up
FastEthernet0/1    unassigned      YES NVRAM  administratively down down
Serial0/0/0        192.168.1.131  YES manual up          up
Serial0/0/1        unassigned      YES NVRAM  administratively down down
Vlan1              unassigned      YES unset  administratively down down
cali#!
```

Ctrl+F6 to exit CLI focus

Copy Paste

Top

Hemos verificado que las interfaces están bien configurados.

b. Después de cargada la configuración en los dispositivos, verificar la tabla de enrutamiento en cada uno de los routers para comprobar las redes y sus rutas.

Analizamos las tablas de enrutamiento.

class1
cisco1
ACL 151

192.168.1.2/27
PC-PT WS-1

192.168.1.34/27
PC-PT PC12

192.168.1.35/27
PC-PT PC14

2960-24TT Switch0

interface fa 0/0
192.168.1.33 / 27

184 Medellin

192.168.1.30/27

Medellin

Physical Config CLI Attributes

IOS Command Line Interface

```
Vlan1              unassigned      YES unset  administratively down down
MEDELLIN#!
MEDELLIN#
MEDELLIN#show ip route
Codes: C - connected, S - static, I - IGRP, R - RIP, M - mobile, B - BGP
D - EIGRP, EX - EIGRP external, O - OSPF, IA - OSPF inter area
N1 - OSPF NSSA external type 1, N2 - OSPF NSSA external type 2
E1 - OSPF external type 1, E2 - OSPF external type 2, E - EGP
i - IS-IS, L1 - IS-IS level-1, L2 - IS-IS level-2, ia - IS-IS inter area
* - candidate default, U - per-user static route, o - ODR
P - periodic downloaded static route

Gateway of last resort is not set

  192.168.1.0/27 is subnetted, 2 subnets
C       192.168.1.32 is directly connected, FastEthernet0/0
C       192.168.1.96 is directly connected, Serial0/0/0

MEDELLIN#
MEDELLIN#!
```

Ctrl+F6 to exit CLI focus

Copy Paste

Top

c. Realizar una prueba de conectividad en cada tramo de la ruta usando Ping.

The screenshot shows a network topology in a simulation environment. On the left, a network diagram displays several devices: PC-PT WS-1 (192.168.1.2/27), Server-PT Server0 (192.168.1.30/27), PC-PT PC12 (192.168.1.34/27), PC-PT PC14 (192.168.1.35/27), 2960-24TT Switch0, 2960-24TT Switch1, 1841 Bogota, 1841 Medellin, and 1841 Cali. The Bogota router is connected to Switch1, Switch0, and Cali. Switch0 is connected to PC12 and PC14. Switch1 is connected to WS-1 and Server0. The Bogota router has interfaces fa 0/0 (192.168.1.1/27), s 0/0 (192.168.1.98/27), and s 0/1 (192.168.1.130/27). Switch0 has interfaces fa 0/0 (192.168.1.33/27) and se 0/0 (192.168.1.99/27). Switch1 has interfaces fa 0/0 (192.168.1.1/27) and se 0/0 (192.168.1.99/27). Cali has interface fa 0/0 (192.168.1.65/27). A red lightning bolt symbol is shown between the Bogota and Cali routers, indicating a connectivity issue.

On the right, a terminal window for PC14 shows the following ping results:

```

C:\>ping 192.168.1.34
Pinging 192.168.1.34 with 32 bytes of data:
Reply from 192.168.1.34: bytes=32 time=9ms TTL=128
Reply from 192.168.1.34: bytes=32 time=4ms TTL=128
Reply from 192.168.1.34: bytes=32 time=5ms TTL=128
Reply from 192.168.1.34: bytes=32 time=5ms TTL=128

Ping statistics for 192.168.1.34:
    Packets: Sent = 4, Received = 4, Lost = 0 (0% loss),
    Approximate round trip times in milli-seconds:
        Minimum = 0ms, Maximum = 9ms, Average = 4ms

C:\>ping 192.168.1.2
Pinging 192.168.1.2 with 32 bytes of data:
Reply from 192.168.1.33: Destination host unreachable.
Reply from 192.168.1.33: Destination host unreachable.
Reply from 192.168.1.33: Destination host unreachable.
Reply from 192.168.1.33: Destination host unreachable.

Ping statistics for 192.168.1.2:
    Packets: Sent = 4, Received = 0, Lost = 4 (100% loss),

C:\>ping 192.168.1.30
Pinging 192.168.1.30 with 32 bytes of data:
Reply from 192.168.1.33: Destination host unreachable.
Reply from 192.168.1.33: Destination host unreachable.
Reply from 192.168.1.33: Destination host unreachable.
Reply from 192.168.1.33: Destination host unreachable.

Ping statistics for 192.168.1.30:
    Packets: Sent = 4, Received = 0, Lost = 4 (100% loss),
  
```

Según el resultado que tenemos observamos que solo podemos tener conectividad con las redes vecinas.

Parte 3: Configuración de Enrutamiento.

a. Asignar el protocolo de enrutamiento EIGRP a los routers considerando el direccionamiento diseñado.

Configuración Interfaces Router Bogotá.

```

BOGOTA(config-if)#router eigrp 200
BOGOTA(config-router)#no auto-summary
BOGOTA(config-router)#network 192.168.1.0
  
```

Configuración Interfaces Router Medellín.

```
MEDELLIN(config-if)#router eigrp 200
MEDELLIN(config-router)#no auto-summary
MEDELLIN(config-router)#network 192.168.1.0
```

Configuración Interfaces Router CALI.

```
CALI(config-if)#router eigrp 200
CALI(config-router)#no auto-summary
CALI(config-router)#network 192.168.1.0
```

A medida que hagamos la configuración del protocolo EIGRP se van generando las adyacencias, hecho el paso anterior debemos proceder a verificar que cada router cuente con una ruta para cada una de las subredes.

b. Verificar si existe vecindad con los routers configurados con EIGRP.

SHOW IP EIGRP NEIGHBOR

BOGOTA#show ip eigrp neighbor

```
IP-EIGRP neighbors for process 200
H Address Interface Hold Uptime SRTT RTO Q Seq
(sec) (ms) Cnt Num
0 192.168.1.99 Se0/0/0 13 00:04:34 40 1000 0 7
1 192.168.1.231 Se0/0/1 12 00:03:31 40 1000 0 7
```

MEDELLIN#show ip eigrp neighbor

```
IP-EIGRP neighbors for process 200
H Address Interface Hold Uptime SRTT RTO Q Seq
(sec) (ms) Cnt Num
```

0 192.168.1.98 Se0/0/0 11 00:04:40 40 1000 0 7

CALI#show ip eigrp neighbor

IP-EIGRP neighbors for process 200

H	Address	Interface	Hold	Uptime	SRTT	RTO	Q	Seq
(sec)	(ms)							

0	192.168.1.130	Se0/0/0	12	00:03:47	40	1000	0	8
---	---------------	---------	----	----------	----	------	---	---

SHOW IP EIGRP TOPOLOGY

BOGOTA#show ip eigrp topology

IP-EIGRP Topology Table for AS 200/ID(192.168.1.130)

Codes: P - Passive, A - Active, U - Update, Q - Query, R - Reply,
r - Reply status

P 192.168.1.0/27, 1 successors, FD is 28160

via Connected, FastEthernet0/0

P 192.168.1.32/27, 1 successors, FD is 2172416

via 192.168.1.99 (2172416/28160), Serial0/0/0

P 192.168.1.64/27, 1 successors, FD is 2172416

via 192.168.1.231 (2172416/28160), Serial0/0/1

P 192.168.1.96/27, 1 successors, FD is 2169856

via Connected, Serial0/0/0

P 192.168.1.128/27, 1 successors, FD is 2169856

via Connected, Serial0/0/1

MEDELLIN#show ip eigrp topology

IP-EIGRP Topology Table for AS 200/ID(192.168.1.99)

Codes: P - Passive, A - Active, U - Update, Q - Query, R - Reply,
r - Reply status

P 192.168.1.0/27, 1 successors, FD is 2172416

via 192.168.1.98 (2172416/28160), Serial0/0/0

P 192.168.1.32/27, 1 successors, FD is 28160

via Connected, FastEthernet0/0

P 192.168.1.64/27, 1 successors, FD is 2684416

via 192.168.1.98 (2684416/2172416), Serial0/0/0

P 192.168.1.96/27, 1 successors, FD is 2169856

via Connected, Serial0/0/0

P 192.168.1.128/27, 1 successors, FD is 2681856

via 192.168.1.98 (2681856/2169856), Serial0/0/0

CALI#show ip eigrp topology

IP-EIGRP Topology Table for AS 200/ID(192.168.1.231)

Codes: P - Passive, A - Active, U - Update, Q - Query, R - Reply,
r - Reply status

P 192.168.1.0/27, 1 successors, FD is 2172416

via 192.168.1.130 (2172416/28160), Serial0/0/0

P 192.168.1.32/27, 1 successors, FD is 2684416

via 192.168.1.130 (2684416/2172416), Serial0/0/0

P 192.168.1.64/27, 1 successors, FD is 28160

via Connected, FastEthernet0/0

P 192.168.1.96/27, 1 successors, FD is 2681856

via 192.168.1.130 (2681856/2169856), Serial0/0/0

P 192.168.1.128/27, 1 successors, FD is 2169856

via Connected, Serial0/0/0

```

class1
cisco1
ACL 151

interface s 0
192.168.1.99/27

interface fa 0/0
192.168.1.33 / 27

interface se 0/0
192.168.1.99 / 27

PC-PT WS-1
192.168.1.2/27

2960-24TT Switch0
192.168.1.34/27
192.168.1.35/27

PC-PT PC14
PC-PT PC12
1841 Medellin
  
```

```

MEDELLIN>enable
MEDELLIN#show ip eigrp neighbor
IP-EIGRP neighbors for process 200
H Address      Interface      Hold Uptime    SRTT  RTO  Q  Seq
(sec)         (ms)          (sec)          (ms)  Cnt  Num
0 192.168.1.98 Se0/0/0        13   00:00:30  40   1000 0 5

MEDELLIN#show ip eigrp topology
IP-EIGRP Topology Table for AS 200/ID(192.168.1.99)

Codes: P - Passive, A - Active, U - Update, Q - Query, R - Reply,
       r - Reply status

P 192.168.1.0/27, 1 successors, FD is 2172416
   via 192.168.1.98 (2172416/28160), Serial0/0/0
P 192.168.1.32/27, 1 successors, FD is 28160
   via Connected, FastEthernet0/0
P 192.168.1.64/27, 1 successors, FD is 2684416
   via 192.168.1.98 (2684416/2172416), Serial0/0/0
P 192.168.1.96/27, 1 successors, FD is 2169856
   via Connected, Serial0/0/0
P 192.168.1.128/27, 1 successors, FD is 2681856
   via 192.168.1.98 (2681856/2169856), Serial0/0/0
MEDELLIN#!
  
```

```

class1
cisco1
ACL 151

interface fa 0/0
192.168.1.1 / 27

interface se 0/0
192.168.1.99 / 27

interface se 0/0
192.168.1.99 / 27

PC-PT WS-1
192.168.1.2/27

2960-24TT Switch1
192.168.1.1/27

2960-24TT Switch0
192.168.1.34/27
192.168.1.35/27

PC-PT PC14
PC-PT PC12
1841 Medellin
1841 Bogota
  
```

```

bogota#enable
bogota#show ip eigrp neighbor
IP-EIGRP neighbors for process 200
H Address      Interface      Hold Uptime    SRTT  RTO  Q  Seq
(sec)         (ms)          (sec)          (ms)  Cnt  Num
0 192.168.1.99 Se0/0/0        13   00:00:37  40   1000 0 7
1 192.168.1.131 Se0/0/1        14   00:00:37  40   1000 0 7

bogota#show ip eigrp topology
IP-EIGRP Topology Table for AS 200/ID(192.168.1.130)

Codes: P - Passive, A - Active, U - Update, Q - Query, R - Reply,
       r - Reply status

P 192.168.1.0/27, 1 successors, FD is 28160
   via Connected, FastEthernet0/0
P 192.168.1.32/27, 1 successors, FD is 2172416
   via 192.168.1.99 (2172416/28160), Serial0/0/0
P 192.168.1.64/27, 1 successors, FD is 2172416
   via 192.168.1.131 (2172416/28160), Serial0/0/1
P 192.168.1.96/27, 1 successors, FD is 2169856
   via Connected, Serial0/0/0
P 192.168.1.128/27, 1 successors, FD is 2169856
   via Connected, Serial0/0/1
bogota#!
  
```

class1
cisco1
ACL 151

192.168.1.2/27
PC-PT WS-1
2960-24TT Switch1
interface fa 0/0
192.168.1.1 / 27

192.168.1.34/27
PC-PT PC12
2960-24TT Switch0
192.168.1.35/27
PC-PT PC14
interface fa 0/0
192.168.1.33 / 27

1841 Bogota
interface s 0/0
192.168.1.98 / 27
interface se 0/0
192.168.1.99 / 27

1841 Medellin
interface fa 0/0
192.168.1.33 / 27

Cali

Physical Config CLI Attributes

IOS Command Line Interface

```

Cali#
Cali#show ip eigrp neighbor
IP-EIGRP neighbors for process 200
H Address Interface Hold Uptime SRTT RTO Q Seq
(sec) (ms) Cnt Num
0 192.168.1.130 Se0/0/0 11 00:00:58 40 1000 0 6

Cali#
Cali#show ip eigrp topology
IP-EIGRP Topology Table for AS 200/ID(192.168.1.131)

Codes: P - Passive, A - Active, U - Update, Q - Query, R - Reply,
       r - Reply status

P 192.168.1.0/27, 1 successors, FD is 2172416
   via 192.168.1.130 (2172416/28160), Serial0/0/0
P 192.168.1.32/27, 1 successors, FD is 2684416
   via 192.168.1.130 (2684416/2172416), Serial0/0/0
P 192.168.1.64/27, 1 successors, FD is 28160
   via Connected, FastEthernet0/0
P 192.168.1.96/27, 1 successors, FD is 2681856
   via 192.168.1.130 (2681856/2169856), Serial0/0/0
P 192.168.1.128/27, 1 successors, FD is 2169856
   via Connected, Serial0/0/0

Cali#
Cali#!
    
```

Observamos que cada router si esta detectando al VECINO.

c. Realizar la comprobación de las tablas de enrutamiento en cada uno de los routers para verificar cada una de las rutas establecidas.

SHOW IP ROUTE

BOGOTA#show ip route

Codes: C - connected, S - static, I - IGRP, R - RIP, M - mobile, B - BGP
D - EIGRP, EX - EIGRP external, O - OSPF, IA - OSPF inter area
N1 - OSPF NSSA external type 1, N2 - OSPF NSSA external type 2
E1 - OSPF external type 1, E2 - OSPF external type 2, E - EGP
i - IS-IS, L1 - IS-IS level-1, L2 - IS-IS level-2, ia - IS-IS inter area
* - candidate default, U - per-user static route, o - ODR
P - periodic downloaded static route

Gateway of last resort is not set

192.168.1.0/27 is subnetted, 5 subnets

C 192.168.1.0 is directly connected, FastEthernet0/0

D 192.168.1.32 [90/2172416] via 192.168.1.99, 00:04:34, Serial0/0/0

D 192.168.1.64 [90/2172416] via 192.168.1.231, 00:03:31, Serial0/0/1

C 192.168.1.96 is directly connected, Serial0/0/0

C 192.168.1.128 is directly connected, Serial0/0/1

MEDELLIN#show ip route

Codes: C - connected, S - static, I - IGRP, R - RIP, M - mobile, B - BGP

D - EIGRP, EX - EIGRP external, O - OSPF, IA - OSPF inter area

N1 - OSPF NSSA external type 1, N2 - OSPF NSSA external type 2

E1 - OSPF external type 1, E2 - OSPF external type 2, E - EGP

i - IS-IS, L1 - IS-IS level-1, L2 - IS-IS level-2, ia - IS-IS inter area

* - candidate default, U - per-user static route, o - ODR

P - periodic downloaded static route

Gateway of last resort is not set

192.168.1.0/27 is subnetted, 5 subnets

D 192.168.1.0 [90/2172416] via 192.168.1.98, 00:04:41, Serial0/0/0

C 192.168.1.32 is directly connected, FastEthernet0/0

D 192.168.1.64 [90/2684416] via 192.168.1.98, 00:03:38, Serial0/0/0

C 192.168.1.96 is directly connected, Serial0/0/0

D 192.168.1.128 [90/2681856] via 192.168.1.98, 00:03:44, Serial0/0/0

CALI#show ip route

Codes: C - connected, S - static, I - IGRP, R - RIP, M - mobile, B - BGP

- D - EIGRP, EX - EIGRP external, O - OSPF, IA - OSPF inter area
- N1 - OSPF NSSA external type 1, N2 - OSPF NSSA external type 2
- E1 - OSPF external type 1, E2 - OSPF external type 2, E - EGP
- i - IS-IS, L1 - IS-IS level-1, L2 - IS-IS level-2, ia - IS-IS inter area
- * - candidate default, U - per-user static route, o - ODR
- P - periodic downloaded static route

Gateway of last resort is not set

192.168.1.0/27 is subnetted, 5 subnets

D 192.168.1.0 [90/2172416] via 192.168.1.130, 00:03:47, Serial0/0/0

D 192.168.1.32 [90/2684416] via 192.168.1.130, 00:03:47, Serial0/0/0

C 192.168.1.64 is directly connected, FastEthernet0/0

D 192.168.1.96 [90/2681856] via 192.168.1.130, 00:03:47, Serial0/0/0

C 192.168.1.128 is directly connected, Serial0/0/0

The image shows a network diagram and a CLI screenshot. The diagram features a central 2960-24TT Switch0 connected to three PCs: PC12 (192.168.1.34/27), PC14 (192.168.1.35/27), and PC13 (192.168.1.67/27). A CLI window titled 'Medellín' displays the output of the 'show ip route' command, which includes a legend for route codes and the specific routing table entries for the 192.168.1.0/27 network.

```

class1
cisco1
ACL 151

Medellín
Physical Config CLI Attributes
IOS Command Line Interface
MEDELLIN#
MEDELLIN#show ip route
Codes: C - connected, S - static, I - IGRP, R - RIP, M - mobile, B - BGP
D - EIGRP, EX - EIGRP external, O - OSPF, IA - OSPF inter area
N1 - OSPF NSSA external type 1, N2 - OSPF NSSA external type 2
E1 - OSPF external type 1, E2 - OSPF external type 2, E - EGP
i - IS-IS, L1 - IS-IS level-1, L2 - IS-IS level-2, ia - IS-IS inter area
* - candidate default, U - per-user static route, o - ODR
P - periodic downloaded static route

Gateway of last resort is not set

  192.168.1.0/27 is subnetted, 5 subnets
    D 192.168.1.0 [90/2172416] via 192.168.1.98, 00:04:19, Serial0/0/0
    C 192.168.1.32 is directly connected, FastEthernet0/0
    D 192.168.1.64 [90/2684416] via 192.168.1.98, 00:04:18, Serial0/0/0
    C 192.168.1.96 is directly connected, Serial0/0/0
    D 192.168.1.128 [90/2681856] via 192.168.1.98, 00:04:19, Serial0/0/0
MEDELLIN#!
Ctrl+F6 to exit CLI focus
Copy Paste
 Top
  
```

Bogotá

Physical Config **CLI** Attributes

IOS Command Line Interface

```

bogota#show ip route
Codes: C - connected, S - static, I - IGRP, R - RIP, M - mobile, B - BGP
       D - EIGRP, EX - EIGRP external, O - OSPF, IA - OSPF inter area
       N1 - OSPF NSSA external type 1, N2 - OSPF NSSA external type 2
       E1 - OSPF external type 1, E2 - OSPF external type 2, E - EGP
       i - IS-IS, L1 - IS-IS level-1, L2 - IS-IS level-2, ia - IS-IS inter
       area
       * - candidate default, U - per-user static route, o - ODR
       P - periodic downloaded static route

Gateway of last resort is not set

192.168.1.0/27 is subnetted, 5 subnets
C    192.168.1.0 is directly connected, FastEthernet0/0
D    192.168.1.32 [90/2172416] via 192.168.1.99, 00:04:33, Serial0/0/0
D    192.168.1.64 [90/2172416] via 192.168.1.131, 00:04:32, Serial0/0/1
C    192.168.1.96 is directly connected, Serial0/0/0
C    192.168.1.128 is directly connected, Serial0/0/1

bogota#
bogota#!
    
```

Ctrl+F6 to exit CLI focus

Copy Paste

Top

Cali

Physical Config **CLI** Attributes

IOS Command Line Interface

```

cali#show ip route
Codes: C - connected, S - static, I - IGRP, R - RIP, M - mobile, B - BGP
       D - EIGRP, EX - EIGRP external, O - OSPF, IA - OSPF inter area
       N1 - OSPF NSSA external type 1, N2 - OSPF NSSA external type 2
       E1 - OSPF external type 1, E2 - OSPF external type 2, E - EGP
       i - IS-IS, L1 - IS-IS level-1, L2 - IS-IS level-2, ia - IS-IS inter area
       * - candidate default, U - per-user static route, o - ODR
       P - periodic downloaded static route

Gateway of last resort is not set

192.168.1.0/27 is subnetted, 5 subnets
D    192.168.1.0 [90/2172416] via 192.168.1.130, 00:04:49, Serial0/0/0
D    192.168.1.32 [90/2684416] via 192.168.1.130, 00:04:49, Serial0/0/0
C    192.168.1.64 is directly connected, FastEthernet0/0
D    192.168.1.96 [90/2681856] via 192.168.1.130, 00:04:49, Serial0/0/0
C    192.168.1.128 is directly connected, Serial0/0/0

cali#
cali#!
    
```

Ctrl+F6 to exit CLI focus

Copy Paste

Top

d. Realizar un diagnóstico para comprobar que cada uno de los puntos de la red se puedan ver y tengan conectividad entre sí. Realizar esta prueba desde un host de la red LAN del router CALI, primero a la red de MEDELLIN y luego al servidor.

The screenshot shows a network simulation environment with a central router labeled 'Bogotá' (1841) connected to three other routers: 'Switch1' (2960-24TT), 'Medellin' (1841), and 'Cali' (1841). Each router is connected to various hosts and servers. The terminal window on the right shows the output of a traceroute command executed from the Cali router:

```

MEDELLIN#tracert 192.168.1.34
Type escape sequence to abort.
Tracing the route to 192.168.1.34

 0  *  2 msec  0 msec
MEDELLIN#tracert 192.168.1.35
Type escape sequence to abort.
Tracing the route to 192.168.1.35

 0  *  3 msec  0 msec
MEDELLIN#tracert 192.168.1.2
Type escape sequence to abort.
Tracing the route to 192.168.1.2

 0  192.168.1.98  17 msec  0 msec  0 msec
 1  *  0 msec  10 msec
MEDELLIN#tracert 192.168.1.30
Type escape sequence to abort.
Tracing the route to 192.168.1.30

 0  192.168.1.98  1 msec  0 msec  1 msec
 1  *  25 msec  150 msec
MEDELLIN#tracert 192.168.1.66
Type escape sequence to abort.
Tracing the route to 192.168.1.66

 0  192.168.1.98  8 msec  0 msec  1 msec
 1  192.168.1.131  1 msec  2 msec  1 msec
 2  *  0 msec  12 msec
MEDELLIN#tracert 192.168.1.67
Type escape sequence to abort.
Tracing the route to 192.168.1.67

 0  192.168.1.98  1 msec  0 msec  0 msec
 1  192.168.1.131  2 msec  1 msec  1 msec
 2  *  4 msec  14 msec
MEDELLIN#
  
```

Este comando fue aplicado desde MEDELLÍN, vemos que tenemos rutas para cada una de las redes.

PING desde PC 14.

The screenshot displays a network simulation interface. On the left, a network topology diagram shows several devices connected in a mesh-like structure. Key components include:

- PC 14** (192.168.1.35/27) connected to **Switch0** (2960-24TT).
- Switch0** connected to **Medellin** (1841) and **Switch1** (2960-24TT).
- Switch1** connected to **WS-1** (192.168.1.2/27) and **Server-PT** (192.168.1.30/27).
- Switch1** also connects to a central **Rogota** (1841) router.
- The **Rogota** router has multiple interfaces: **fa 0/0** (192.168.1.1/27), **s 0/0** (192.168.1.90/27), **s 0/1** (192.168.1.130/27), **se 0/0** (192.168.1.33/27), **se 0/0** (192.168.1.39/27), and **fa 0/0** (192.168.1.131/27).
- Medellin** (1841) has an interface **fa 0/0** (192.168.1.65/27).

On the right, a **Command Prompt** window shows the results of ping tests from PC 14 to various destinations:

```

C:\>ping 192.168.1.34

Reply from 192.168.1.34: bytes=32 time=1ms TTL=128
Reply from 192.168.1.34: bytes=32 time=1ms TTL=128
Reply from 192.168.1.34: bytes=32 time=1ms TTL=128
Reply from 192.168.1.34: bytes=32 time=3ms TTL=128

Ping statistics for 192.168.1.34:
    Packets: Sent = 4, Received = 4, Lost = 0 (0% loss),
    Approximate round trip times in milli-seconds:
        Minimum = 0ms, Maximum = 3ms, Average = 1ms

C:\>ping 192.168.1.2

Pinging 192.168.1.2 with 32 bytes of data:

Reply from 192.168.1.2: bytes=32 time=1ms TTL=126
Reply from 192.168.1.2: bytes=32 time=1ms TTL=126
Reply from 192.168.1.2: bytes=32 time=2ms TTL=126
Reply from 192.168.1.2: bytes=32 time=2ms TTL=126

Ping statistics for 192.168.1.2:
    Packets: Sent = 4, Received = 4, Lost = 0 (0% loss),
    Approximate round trip times in milli-seconds:
        Minimum = 1ms, Maximum = 2ms, Average = 16ms

C:\>ping 192.168.1.30

Pinging 192.168.1.30 with 32 bytes of data:

Reply from 192.168.1.30: bytes=32 time=9ms TTL=126
Reply from 192.168.1.30: bytes=32 time=15ms TTL=126
Reply from 192.168.1.30: bytes=32 time=15ms TTL=126
Reply from 192.168.1.30: bytes=32 time=15ms TTL=126

Ping statistics for 192.168.1.30:
    Packets: Sent = 4, Received = 4, Lost = 0 (0% loss),
    Approximate round trip times in milli-seconds:
        Minimum = 9ms, Maximum = 15ms, Average = 14ms

C:\>ping 192.168.1.66

Pinging 192.168.1.66 with 32 bytes of data:

Reply from 192.168.1.66: bytes=32 time=3ms TTL=125
Reply from 192.168.1.66: bytes=32 time=1ms TTL=125
Reply from 192.168.1.66: bytes=32 time=1ms TTL=125
Reply from 192.168.1.66: bytes=32 time=3ms TTL=125

Ping statistics for 192.168.1.66:
    Packets: Sent = 4, Received = 4, Lost = 0 (0% loss),
    Approximate round trip times in milli-seconds:
        Minimum = 3ms, Maximum = 3ms, Average = 10ms
    
```

Igualmente empleando el comando PING nos da respuesta desde todos los puntos de la red.

Parte 4: Configuración de las listas de Control de Acceso.

En este momento cualquier usuario de la red tiene acceso a todos sus dispositivos y estaciones de trabajo. El jefe de redes le solicita implementar seguridad en la red. Para esta labor se decide configurar listas de control de acceso (ACL) a los routers.

Las condiciones para crear las ACL son las siguientes:

- a. El equipo WS1 y el servidor se encuentran en la subred de administración. Solo el servidor de la subred de administración debe tener acceso a cualquier otro dispositivo en cualquier parte de la red.

```
BOGOTA(config)#access-list 151 permit ip host 192.168.1.30 any
BOGOTA(config)#int f0/0
BOGOTA(config-if)#ip access-group 151 in
```

Segun la restricci3n que hemos aplicado si hacemos un PING desde WS1 la respuesta es Destino Inalcanzable:

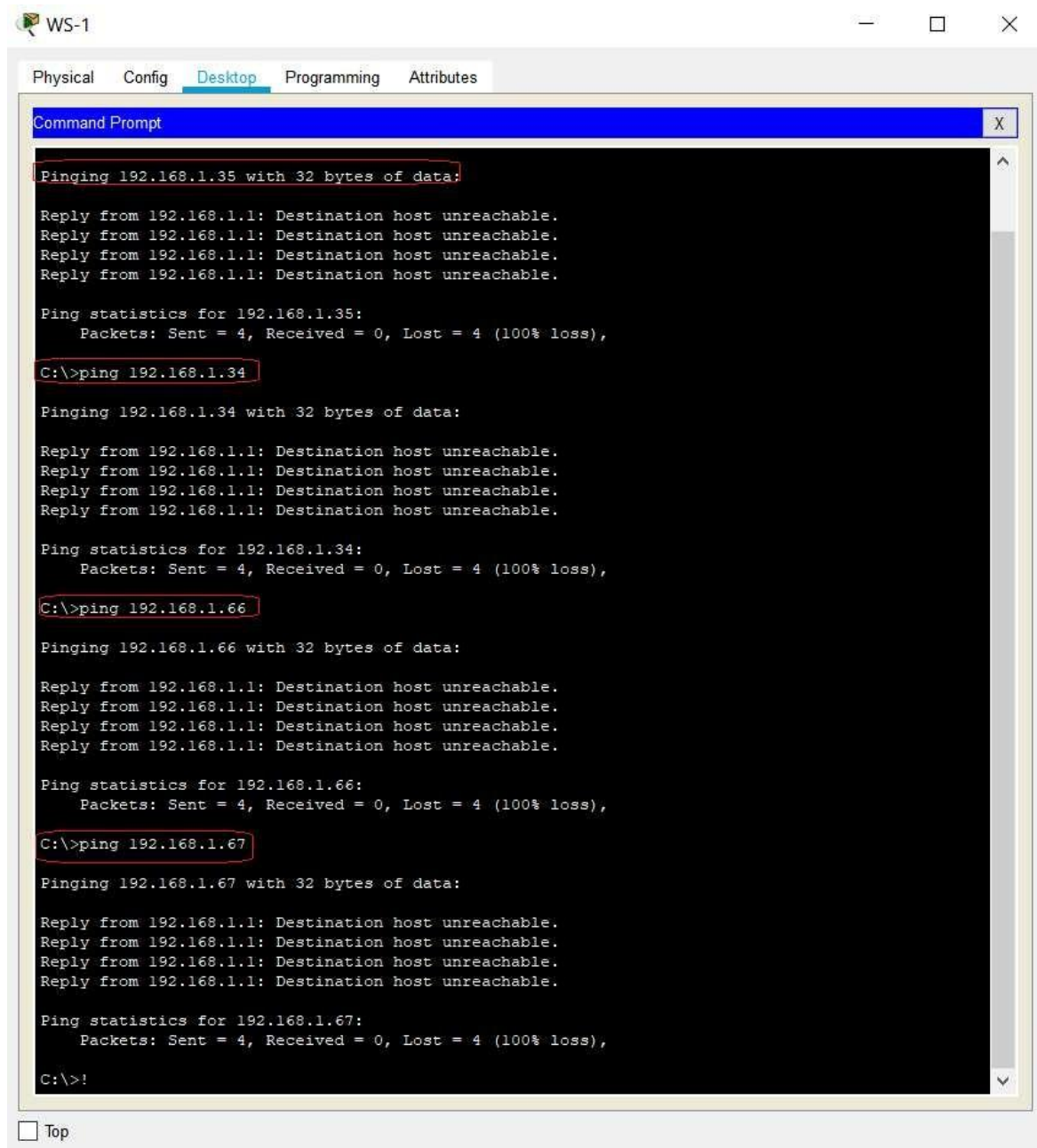

```
WS-1
Physical Config Desktop Programming Attributes
Command Prompt
Pinging 192.168.1.35 with 32 bytes of data:
Reply from 192.168.1.1: Destination host unreachable.
Reply from 192.168.1.1: Destination host unreachable.
Reply from 192.168.1.1: Destination host unreachable.
Reply from 192.168.1.1: Destination host unreachable.

Ping statistics for 192.168.1.35:
    Packets: Sent = 4, Received = 0, Lost = 4 (100% loss),

C:\>ping 192.168.1.34

Pinging 192.168.1.34 with 32 bytes of data:

Reply from 192.168.1.1: Destination host unreachable.
Reply from 192.168.1.1: Destination host unreachable.
Reply from 192.168.1.1: Destination host unreachable.
Reply from 192.168.1.1: Destination host unreachable.

Ping statistics for 192.168.1.34:
    Packets: Sent = 4, Received = 0, Lost = 4 (100% loss),

C:\>ping 192.168.1.66

Pinging 192.168.1.66 with 32 bytes of data:

Reply from 192.168.1.1: Destination host unreachable.
Reply from 192.168.1.1: Destination host unreachable.
Reply from 192.168.1.1: Destination host unreachable.
Reply from 192.168.1.1: Destination host unreachable.

Ping statistics for 192.168.1.66:
    Packets: Sent = 4, Received = 0, Lost = 4 (100% loss),

C:\>ping 192.168.1.67

Pinging 192.168.1.67 with 32 bytes of data:

Reply from 192.168.1.1: Destination host unreachable.
Reply from 192.168.1.1: Destination host unreachable.
Reply from 192.168.1.1: Destination host unreachable.
Reply from 192.168.1.1: Destination host unreachable.

Ping statistics for 192.168.1.67:
    Packets: Sent = 4, Received = 0, Lost = 4 (100% loss),

C:\>!
```

Pero si hacemos el PING desde el SERVIDOR todos deben ser satisfactorios:

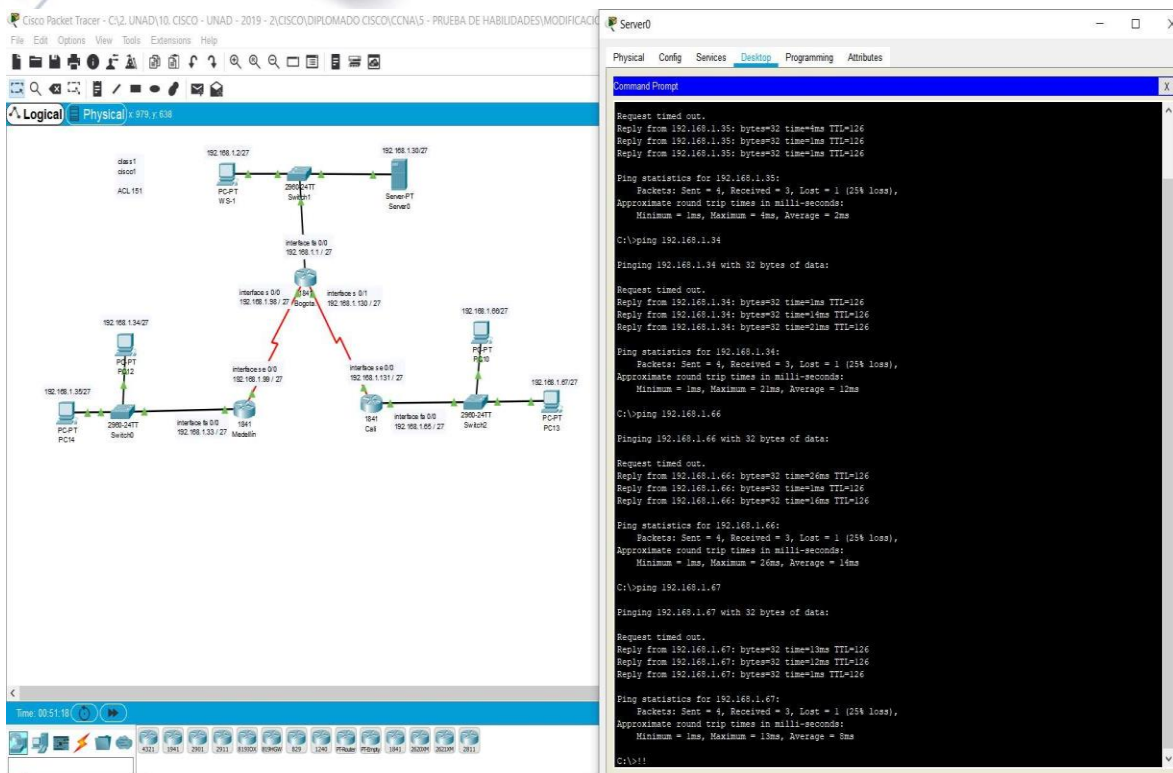

b. Las estaciones de trabajo en las LAN de MEDELLIN y CALI no deben tener acceso a ningún dispositivo fuera de su subred, excepto para interconectar con el servidor.

MEDELLIN(config)#access-list **151** permit ip 192.168.1.32 0.0.0.31 host 192.168.1.30

MEDELLIN(config)#int f0/0

MEDELLIN(config-if)#ip access-group **151** in

MEDELLIN(config-if)#

CALI(config)#access-list **151** permit ip 192.168.1.64 0.0.0.31 host 192.168.1.30

CALI(config)#int f0/0

CALI(config-if)#ip access-group 151 in

CALI(config-if)#

- Ping desde Medellín, hacia los diferentes puntos de la red y hacia el servidor:

The network diagram shows a topology with three main locations: Bogotá, Medellín, and Cali. Bogotá is connected to WS-1, Switch1, and Server0. Medellín is connected to Switch0 and PC14. Cali is connected to Switch2. The Command Prompt on PC14 shows the following output:

```

Packet Tracer PC Command Line 1.0
C:\>ping 192.168.1.66

Pinging 192.168.1.66 with 32 bytes of data:

Reply from 192.168.1.33: Destination host unreachable.
Reply from 192.168.1.33: Destination host unreachable.
Reply from 192.168.1.33: Destination host unreachable.
Reply from 192.168.1.33: Destination host unreachable.

Ping statistics for 192.168.1.66:
    Packets: Sent = 4, Received = 0, Lost = 4 (100% loss),

C:\>ping 192.168.1.30

Pinging 192.168.1.30 with 32 bytes of data:

Request timed out.
Reply from 192.168.1.30: bytes=32 time=17ms TTL=126
Reply from 192.168.1.30: bytes=32 time=15ms TTL=126
Reply from 192.168.1.30: bytes=32 time=12ms TTL=126

Ping statistics for 192.168.1.30:
    Packets: Sent = 4, Received = 3, Lost = 1 (25% loss),
    Approximate round trip times in milli-seconds:
        Minimum = 12ms, Maximum = 17ms, Average = 14ms

C:\>|
  
```

- Ping desde la LAN de CALI hacia los diferentes puntos de la red y hacia el servidor:

The network diagram is the same as above. The Command Prompt on PC13 shows the following output:

```

Packet Tracer PC Command Line 1.0
C:\>ping 192.168.1.30

Pinging 192.168.1.30 with 32 bytes of data:

Reply from 192.168.1.30: bytes=32 time=2ms TTL=126
Reply from 192.168.1.30: bytes=32 time=41ms TTL=126
Reply from 192.168.1.30: bytes=32 time=29ms TTL=126
Reply from 192.168.1.30: bytes=32 time=27ms TTL=126

Ping statistics for 192.168.1.30:
    Packets: Sent = 4, Received = 4, Lost = 0 (0% loss),
    Approximate round trip times in milli-seconds:
        Minimum = 2ms, Maximum = 41ms, Average = 24ms

C:\>ping 192.168.1.34

Pinging 192.168.1.34 with 32 bytes of data:

Reply from 192.168.1.65: Destination host unreachable.
Reply from 192.168.1.65: Destination host unreachable.
Reply from 192.168.1.65: Destination host unreachable.
Reply from 192.168.1.65: Destination host unreachable.

Ping statistics for 192.168.1.34:
    Packets: Sent = 4, Received = 0, Lost = 4 (100% loss),

C:\>|
  
```

En los 2 casos verificamos el correcto funcionamiento de la ACL ingresada, en la cual verificamos que podemos hacer PING hacia el servidor, pero el ping hacia cualquier punto por fuera de la LAN no debe tener efecto, con esto constatamos que todo está funcionando.

Parte 5: Comprobación de la red instalada.

- a. Se debe probar que la configuración de las listas de acceso fue exitosa.
- b. Comprobar y Completar la siguiente tabla de condiciones de prueba para confirmar el óptimo funcionamiento de la red e.

	ORIGEN	DESTINO	RESULTADO	
TELNET	Router MEDELLIN	Router CALI	Éxito	192.168.1.131
	WS_1	Router BOGOTA	Falla	192.168.1.130
	Servidor	Router CALI	Éxito	192.168.1.131
	Servidor	Router MEDELLIN	Éxito	192.168.1.99
TELNET	LAN del Router	Router CALI	Falla	192.168.1.131
	LAN del Router CALI	Router CALI	Falla	192.168.1.131
	LAN del Router	Router MEDELLIN	Falla	192.168.1.99
	LAN del Router CALI	Router MEDELLIN	Falla	192.168.1.99
PING	LAN del Router CALI	WS_1	Falla	192.168.1.2
	LAN del Router	WS_1	Falla	192.168.1.2
PING	LAN del Router	LAN del Router CALI	Falla	192.168.1.67
	LAN del Router CALI	Servidor	Éxito	192.168.1.30
	LAN del Router	Servidor	Éxito	192.168.1.30
	Servidor	LAN del Router MEDELLIN	Éxito	192.168.1.35
	Servidor	LAN del Router CALI	Éxito	192.168.1.66
	Router CALI	LAN del Router MEDELLIN	Falla	192.168.1.35
	Router MEDELLIN	LAN del Router CALI	Falla	192.168.1.66

MEDELLIN	interface serial 0/0	192.168.1.99	255.255.255.224
	interface fa 0/0	192.168.1.33	255.255.255.224
BOGOTA	interface serial 0/0	192.168.1.98	255.255.255.224
	interface serial 0/1	192.168.1.130	255.255.255.224
	interface fa 0/0	192.168.1.1	255.255.255.224
CALI	interface serial 0/0	192.168.1.131	255.255.255.224
	interface fa 0/0	192.168.1.65	255.255.255.224

De una vez configuramos las PC:

MEDELLIN	PC12	192.168.1.34	255.255.255.224	192.168.1.33
MEDELLIN	PC14	192.168.1.35	255.255.255.224	192.168.1.33
CALI	PC10	192.168.1.66	255.255.255.224	192.168.1.65
CALI	PC13	192.168.1.67	255.255.255.224	192.168.1.65
BOGOTA	WS-1	192.168.1.2	255.255.255.224	192.168.1.1
BOGOTA	SERVER	192.168.1.30	255.255.255.224	192.168.1.1

	ORIGEN	DESTINO	RESULTADO	
TELNET	Router MEDELLIN	Router CALI	Éxito	192.168.1.131
	WS_1	Router BOGOTA	Falla	192.168.1.130
	Servidor	Router CALI	Éxito	192.168.1.131
	Servidor	Router	Éxito	192.168.1.99

Medellín

Physical Config **CLI** Attributes

IOS Command Line Interface

```

SOLO PERSONAL DE LA EMPRESA - ACCESO DENEGADO

User Access Verification
Password:
MEDELLIN>enable
Password:
MEDELLIN#
MEDELLIN#telnet 192.168.1.131
Trying 192.168.1.131 ...Open ACCESO DENEGADO!!

User Access Verification
Password:
CALI>enable
Password:
CALI#
CALI#!
            
```

Ctrl+F6 to exit CLI focus

Top

class1
cisco1
ACL 151

WS-1

Physical Config **Desktop** Programming Attributes

Command Prompt

```

Packet Tracer PC Command Line 1.0
C:\>telnet 192.168.1.130
Trying 192.168.1.130 ...
% Connection timed out; remote host not responding
C:\>
C:\>telnet 192.168.1.130
Trying 192.168.1.130 ...
% Connection timed out; remote host not responding
C:\>|
    
```

class1
cisco1
ACL 151

Server0

Physical Config Services **Desktop** Programming Attributes

Command Prompt

```

Packet Tracer SERVER Command Line 1.0
C:\>telnet 192.168.1.131
Trying 192.168.1.131 ...Open ACCESO DENEGADO!!

User Access Verification

Password:
Password:
CALI>enable
Password:
CALI#!
    
```

class1
cisco1
ACL 151

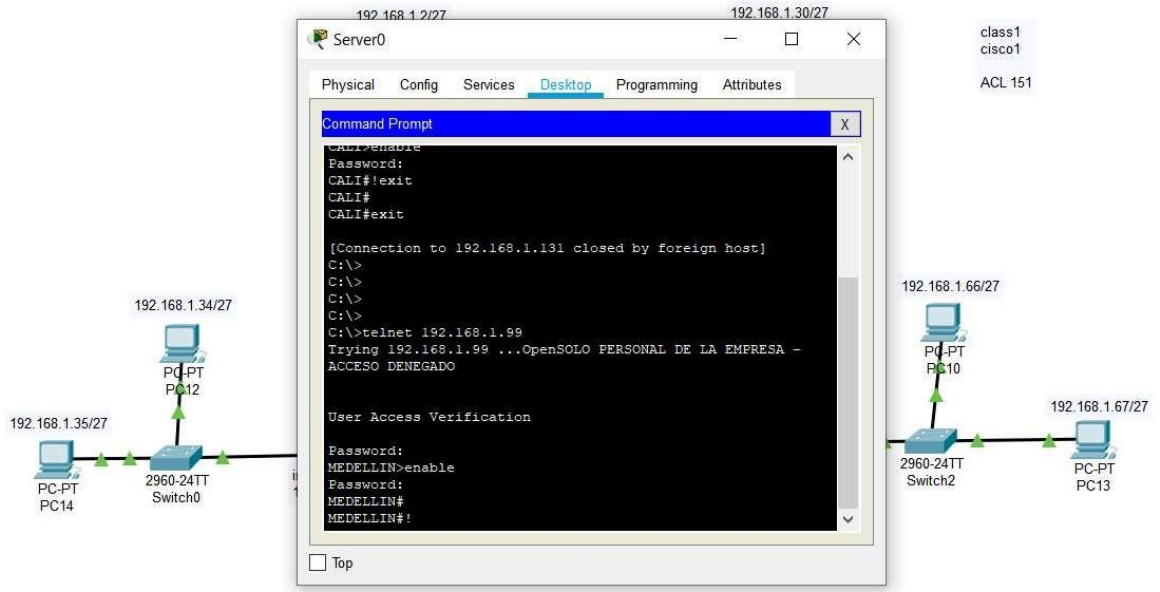

	ORIGEN	DESTINO	RESULTADO	
TELNET	LAN del Router	Router CALI	Falla	192.168.1.131
	LAN del Router CALI	Router CALI	Falla	192.168.1.131
	LAN del Router	Router MEDELLIN	Falla	192.168.1.99
	LAN del Router CALI	Router MEDELLIN	Falla	192.168.1.99

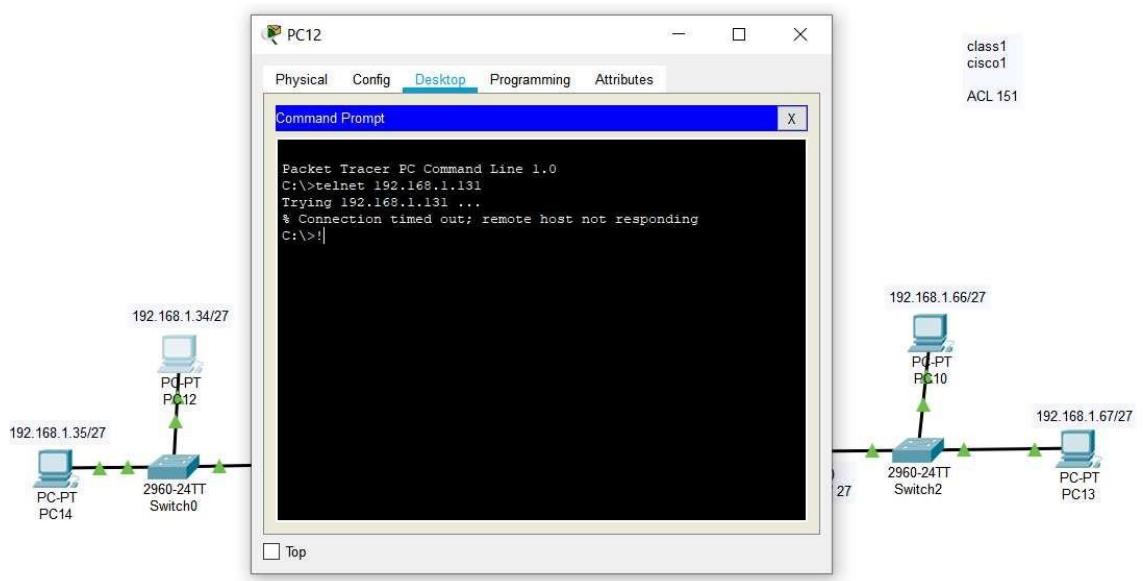

PC13

Physical Config **Desktop** Programming Attributes

Command Prompt

```
Packet Tracer PC Command Line 1.0  
C:\>telnet 192.168.1.131  
Trying 192.168.1.131 ...  
% Connection timed out; remote host not responding  
C:\>!
```

Top

class1
cisco1
ACL 151

PC14

Physical Config **Desktop** Programming Attributes

Command Prompt

```
Packet Tracer PC Command Line 1.0  
C:\>telnet 192.168.1.99  
Trying 192.168.1.99 ...  
% Connection timed out; remote host not responding  
C:\>!
```

Top

class1
cisco1
ACL 151

192.168.1.2/27

192.168.1.30/27

PC10

Physical Config Desktop Programming Attributes

Command Prompt

```
Packet Tracer PC Command Line 1.0  
C:\>telnet 192.168.1.99  
Trying 192.168.1.99 ...  
% Connection timed out; remote host not responding  
C:\>!
```

192.168.1.34/27

PC-PT PC12

2960-24TT Switch0

192.168.1.35/27

PC-PT PC14

192.168.1.66/27

PC-PT PC10

2960-24TT Switch2

192.168.1.67/27

PC-PT PC13

27

Top

class1
cisco1
ACL 151

ESCENARIO 2.

Una empresa tiene la conexión a internet en una red Ethernet, lo cual deben adaptarlo para facilitar que sus routers y las redes que incluyen puedan, por esa vía, conectarse a internet, pero empleando las direcciones de la red LAN original.

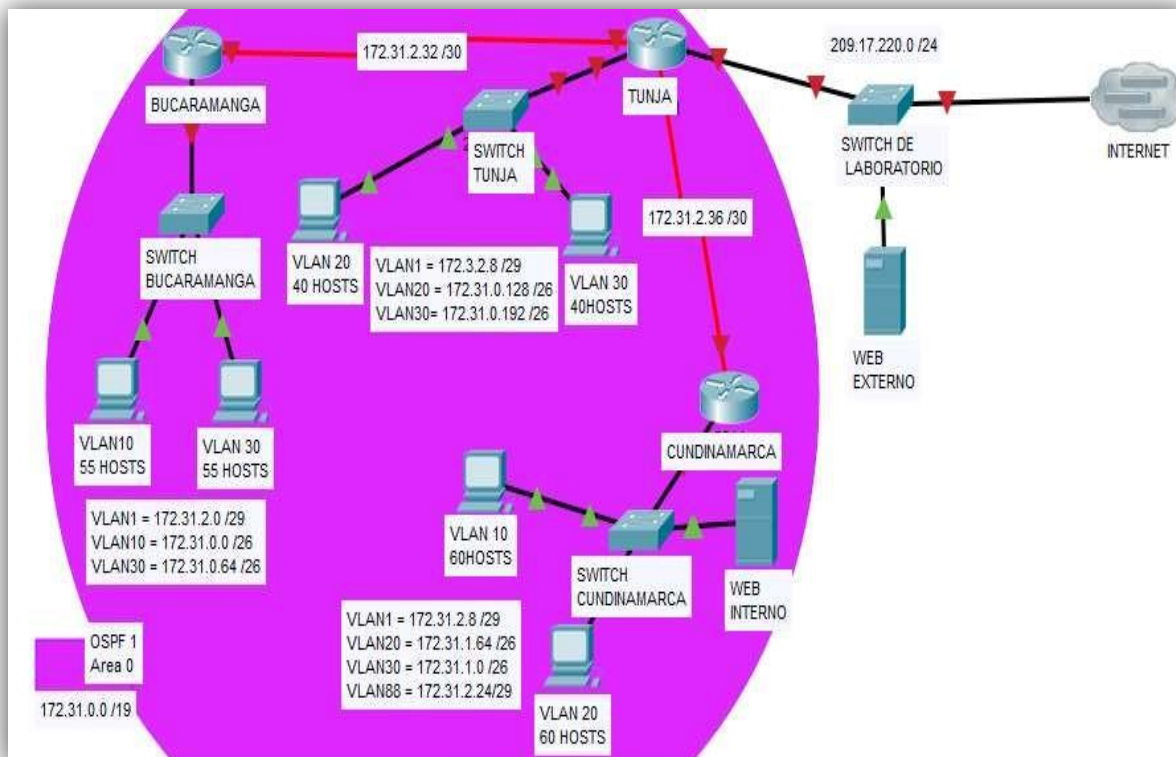

Desarrollo

Los siguientes son los requerimientos necesarios:

Todos los routers deberán tener los siguiente:

- Configuración básica.
- Autenticación local con AAA.
- Cifrado de contraseñas.
- Un máximo de internos para acceder al router.
- Máximo tiempo de acceso al detectar ataques.

- Establezca un servidor TFTP y almacene todos los archivos necesarios de los routers.
1. El DHCP deberá proporcionar solo direcciones a los hosts de Bucaramanga y Cundinamarca
 2. El web server deberá tener NAT estático y el resto de los equipos de la topología emplearan NAT de sobrecarga (PAT).
 3. El enrutamiento deberá tener autenticación.
 4. Listas de control de acceso:
 - Los hosts de VLAN 20 en Cundinamarca no acceden a internet, solo a la red interna de Tunja.
 - Los hosts de VLAN 10 en Cundinamarca si acceden a internet y no a la red interna de Tunja.
 - Los hosts de VLAN 30 en Tunja solo acceden a servidores web y ftp de internet.
 - Los hosts de VLAN 20 en Tunja solo acceden a la VLAN 20 de Cundinamarca y VLAN 10 de Bucaramanga.
 - Los hosts de VLAN 30 de Bucaramanga acceden a internet y a cualquier equipo de VLAN 10.
 - Los hosts de VLAN 10 en Bucaramanga acceden a la red de Cundinamarca (VLAN 20) y Tunja (VLAN 20), no internet.
 - Los hosts de una VLAN no pueden acceder a los de otra VLAN en una ciudad.
 - Solo los hosts de las VLAN administrativas y de la VLAN de servidores tienen acceso a los routers e internet.
 5. VLSM: utilizar la dirección **172.31.0.0 /18** para el direccionamiento.

Aspectos a tener en cuenta

- Habilitar VLAN en cada switch y permitir su enrutamiento.
- Enrutamiento OSPF con autenticación en cada router.
- Servicio **DHCP** en el router Tunja, mediante el **helper address**, para los routers Bucaramanga y Cundinamarca.
- Configuración de NAT estático y de sobrecarga.
- Establecer una lista de control de acceso de acuerdo con los criterios señalados.
- Habilitar las opciones en puerto consola y terminal virtual

DESARROLLO DE LA GUÍA.

Los siguientes son los requerimientos necesarios:

1. Todos los routers deben tener las siguientes configuraciones basicas.

Lo primero que podemos hacer en este caso es configurar los nombres de los dispositivos y los mensajes, recordemos que este es persuasivo para las personas que ingresan sin autorización debida. Este proceso se hace aplicando los siguientes comandos:

```
Router(config)#hostname BUCARAMANGA
BUCARAMANGA(config)#no ip domain-lookup
BUCARAMANGA(config)#banner motd $!! SOLO PERSONAL DE LA EMPRESA -
ACCESO DENEGADO;;$
```

```
Router(config)#hostname TUNJA
```

```
TUNJA(config)#no ip domain-lookup
TUNJA(config)#banner motd $!!ACCESO DENEGADO;i;$
```

```
Router(config)#hostname CUNDINAMARCA
CUNDINAMARCA(config)#no ip domain-lookup
CUNDINAMARCA(config)#banner motd $!! SOLO PERSONAL DE LA EMPRESA
- ACCESO DENEGADO;i;$
```

Continuamos *configurando las contraseñas*, recordemos que esta parte es muy importante, ya que evitan la vulnerabilidad de nuestros dispositivos y de nuestra red. El proceso seguido en cada uno de los dispositivos se indica a continuación:

```
BUCARAMANGA(config)#enable secret class1
BUCARAMANGA(config)#line console 0
BUCARAMANGA(config-line)#password cisco1
BUCARAMANGA(config-line)#login
BUCARAMANGA(config-line)#line vty 0 15
BUCARAMANGA(config-line)#password cisco1
BUCARAMANGA(config-line)#login
BUCARAMANGA(config)#int f0/0.1
```

```
TUNJA(config)#enable secret class1
TUNJA(config)#line console 0
TUNJA(config-line)#password cisco1
TUNJA(config-line)#login
TUNJA(config-line)#line vty 0 15
TUNJA(config-line)#password cisco1
```

TUNJA(config-line)#login

CUNDINAMARCA(config)#enable secret class1

CUNDINAMARCA(config)#line console 0

CUNDINAMARCA(config-line)#password cisco1

CUNDINAMARCA(config-line)#login

CUNDINAMARCA(config-line)#line vty 0 15

CUNDINAMARCA(config-line)#password cisco1

CUNDINAMARCA(config-line)#login

Nuestra red está configurada con una serie de VLAN, por consiguiente debemos como siguiente paso configurar las interfaces, sub-interfaces y el correspondiente encapsulación:

BUCARAMANGA(config-subif)#encapsulation dot1q 1

BUCARAMANGA(config-subif)#ip address 172.31.2.1 255.255.255.248

BUCARAMANGA(config-subif)#int f0/0.10

BUCARAMANGA(config-subif)#encapsulation dot1q 10

BUCARAMANGA(config-subif)#ip address 172.31.0.1 255.255.255.192

BUCARAMANGA(config-subif)#int f0/0.30

BUCARAMANGA(config-subif)#encapsulation dot1q 30

BUCARAMANGA(config-subif)#ip address 172.31.0.65 255.255.255.192

BUCARAMANGA(config-subif)#int f0/0

BUCARAMANGA(config-if)#no shutdown

BUCARAMANGA(config-if)#int s0/0/0

BUCARAMANGA(config-if)#ip address 172.31.2.34 255.255.255.252

```
BUCARAMANGA(config-if)#no shutdown
```

```
BUCARAMANGA(config-if)#
```

No olvidemos que debemos activar cada una de las interfaces. Continuamos el proceso con el router de TUNJA.

```
TUNJA(config)#int f0/0.1
```

```
TUNJA(config-subif)#encapsulation dot1q 1
```

```
TUNJA(config-subif)#ip address 172.3.2.9 255.255.255.248
```

```
TUNJA(config-subif)#int f0/0.20
```

```
TUNJA(config-subif)#encapsulation dot1q 20
```

```
TUNJA(config-subif)#ip address 172.31.0.129 255.255.255.192
```

```
TUNJA(config-subif)#int f0/0.30
```

```
TUNJA(config-subif)#encapsulation dot1q 30
```

```
TUNJA(config-subif)#ip address 172.31.0.193 255.255.255.192
```

```
TUNJA(config-subif)#int f0/0
```

```
TUNJA(config-if)#no shutdown
```

```
TUNJA(config-if)#int s0/0/0
```

```
TUNJA(config-if)#ip address 172.31.2.33 255.255.255.252
```

```
TUNJA(config-if)#no shutdown
```

```
TUNJA(config-if)#int s0/0/1
```

```
TUNJA(config-if)#ip address 172.31.2.37 255.255.255.252
```

```
TUNJA(config-if)#no shutdown
```

```
TUNJA(config-if)#int f0/1
```

```
TUNJA(config-if)#ip address 209.165.220.1 255.255.255.0
```

TUNJA(config-if)#no shutdown

Finalizamos nuestro proceso de configuración de las interfaces con el ROUTER
CUNDINAMARCA:

CUNDINAMARCA(config)#int f0/0.1

CUNDINAMARCA(config-subif)#encapsulation dot1q 1

CUNDINAMARCA(config-subif)#ip address 172.31.2.9 255.255.255.248

CUNDINAMARCA(config-subif)#int f0/0.20

CUNDINAMARCA(config-subif)#encapsulation dot1q 20

CUNDINAMARCA(config-subif)#ip address 172.31.1.65 255.255.255.192

CUNDINAMARCA(config-subif)#int f0/0.30

CUNDINAMARCA(config-subif)#encapsulation dot1q 30

CUNDINAMARCA(config-subif)#ip address 172.31.1.1 255.255.255.192

CUNDINAMARCA(config-subif)#int f0/0.88

CUNDINAMARCA(config-subif)#encapsulation dot1q 88

CUNDINAMARCA(config-subif)#ip address 172.31.2.25 255.255.255.248

CUNDINAMARCA(config-subif)#int f0/0

CUNDINAMARCA(config-if)#no shutdown

CUNDINAMARCA(config-if)#int s0/0/0

CUNDINAMARCA(config-if)#ip address 172.31.2.38 255.255.255.252

CUNDINAMARCA(config-if)#no shutdown

Procedemos ahora a configurar los SWITCHES.

Creamos las VLAN que vamos a necesitar en cada uno de ellos según la imagen que se nos suministra y debemos asignar las interfaces de cada uno de los switches a estas vlan.

Switch-Bucaramanga(config)#vlan 1

Switch-Bucaramanga (config-vlan)#vlan 10

Switch-Bucaramanga (config-vlan)#vlan 30

Switich-Tunja(config)#vlan 1

Switich-Tunja(config-vlan)#vlan 20

Switich-Tunja(config-vlan)#vlan 30

Switich-Cundinamarca(config)#vlan 1

Switich-Cundinamarca(config-vlan)#vlan 20

Switich-Cundinamarca(config-vlan)#vlan 30

Switich-Cundinamarca(config-vlan)#vlan 88

- Tenemos ya creadas las VLAN, pero entonces se debe proceder a asignar las interfaces de los switch a cada una de estas VLAN, con el fin de crear las subredes, tal como lo indicamos a continuación:

Switch-Bucaramanga(config-vlan)#int f0/10

Switch-Bucaramanga(config-if)#switchport mode access

Switch-Bucaramanga(config-if)#switchport access vlan 10

Switch-Bucaramanga(config-if)#int f0/14

```

Switch-Bucaramanga(config-if)#switchport mode access
Switch-Bucaramanga(config-if)#switchport access vlan 30
Switch-Bucaramanga(config-if)#int f0/1
Switch-Bucaramanga(config-if)#switchport mode trunk
Switch-Bucaramanga(config-if)#int vlan 1
Switch-Bucaramanga(config-if)#ip address 172.31.2.3 255.255.255.248
Switch-Bucaramanga(config-if)#no shutdown
Switch-Bucaramanga(config-if)#ip default-gateway 172.31.2.1
Switch-Bucaramanga(config)#

```

```

Switch-Tunja(config-vlan)#int f0/10
Switch-Tunja(config-if)#switchport mode access
Switch-Tunja(config-if)#switchport access vlan 20
Switch-Tunja(config-if)#int f0/14
Switch-Tunja(config-if)#switchport mode access
Switch-Tunja(config-if)#switchport access vlan 30
Switch-Tunja(config-if)#int f0/1
Switch-Tunja(config-if)#switchport mode trunk
Switch-Tunja(config-if)#int vlan 1
Switch-Tunja(config-if)#ip address 172.3.2.11 255.255.255.248
Switch-Tunja(config-if)#no shutdown
Switch-Tunja(config-if)#ip default-gateway 172.3.2.9

```

```

Switch-Cundinamarca(config)#int f0/10
Switch-Cundinamarca(config-if)#switchport mode access
Switch-Cundinamarca(config-if)#switchport access vlan 20
Switch-Cundinamarca(config-if)#int f0/14
Switch-Cundinamarca(config-if)#switchport mode access

```

```

Switch-Cundinamarca(config-if)#switchport access vlan 30
Switch-Cundinamarca(config-if)#int f0/20
Switch-Cundinamarca(config-if)#switchport mode access
Switch-Cundinamarca(config-if)#switchport access vlan 88
Switch-Cundinamarca(config-if)#int f0/1
Switch-Cundinamarca(config-if)#switchport mode trunk
Switch-Cundinamarca(config-if)#int vlan 1
Switch-Cundinamarca(config-if)#ip address 172.31.2.11 255.255.255.248
Switch-Cundinamarca(config-if)#no shutdown
Switch-Cundinamarca(config-if)#ip default-gateway 172.31.2.9
Switch-Cundinamarca(config)#

```

En este punto es importante tambien verificar que nuestra configuración ingresada sea la correcta, este lo hacemos con la utilización de los siguientes comandos:

The diagram shows a network topology with a central switch (Switch-Bucaramanga) connected to a router (Bucaramanga) and two PCs (PC10 and PC11). The router has a serial interface connected to the switch. The switch has three VLANs configured: VLAN 1 (default), VLAN 10, and VLAN 30. The CLI screenshot shows the output of the 'show vlan brief' command, which lists the VLANs and their associated ports.

VLAN Name	Status	Ports
1 default	active	Fa0/2, Fa0/3, Fa0/4, Fa0/5 Fa0/6, Fa0/7, Fa0/8, Fa0/9 Fa0/11, Fa0/12, Fa0/13, Fa0/15 Fa0/16, Fa0/17, Fa0/18, Fa0/19 Fa0/20, Fa0/21, Fa0/22, Fa0/23 Fa0/24, Gig0/1, Gig0/2
10 VLAN0010	active	Fa0/10
30 VLAN0030	active	Fa0/14
1002 fddi-default	active	
1003 token-ring-default	active	
1004 fddinet-default	active	
1005 trnet-default	active	

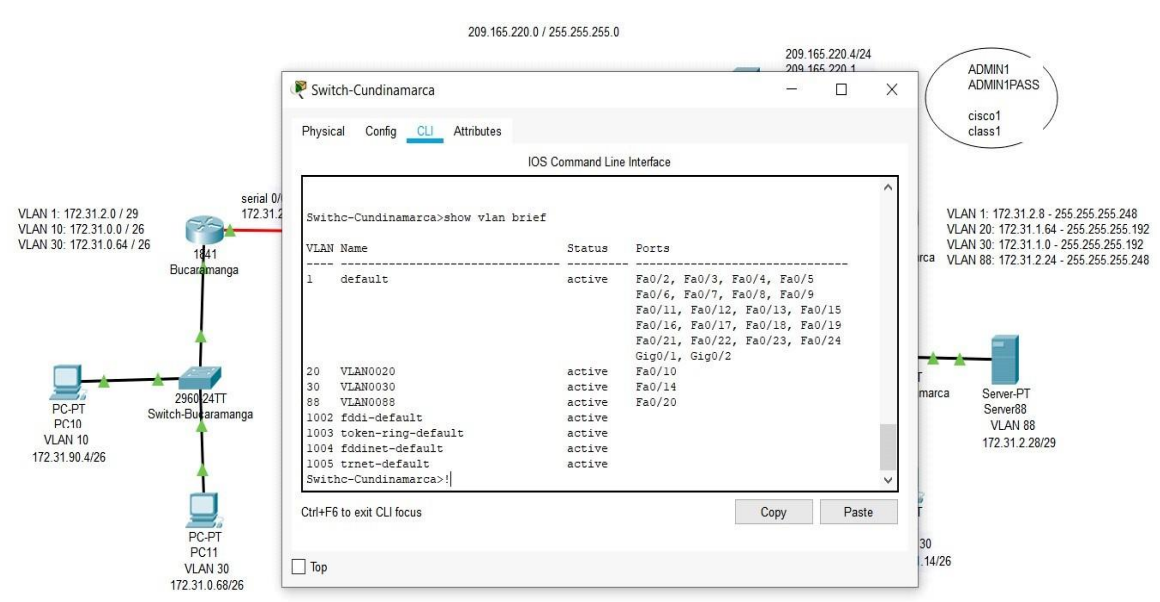
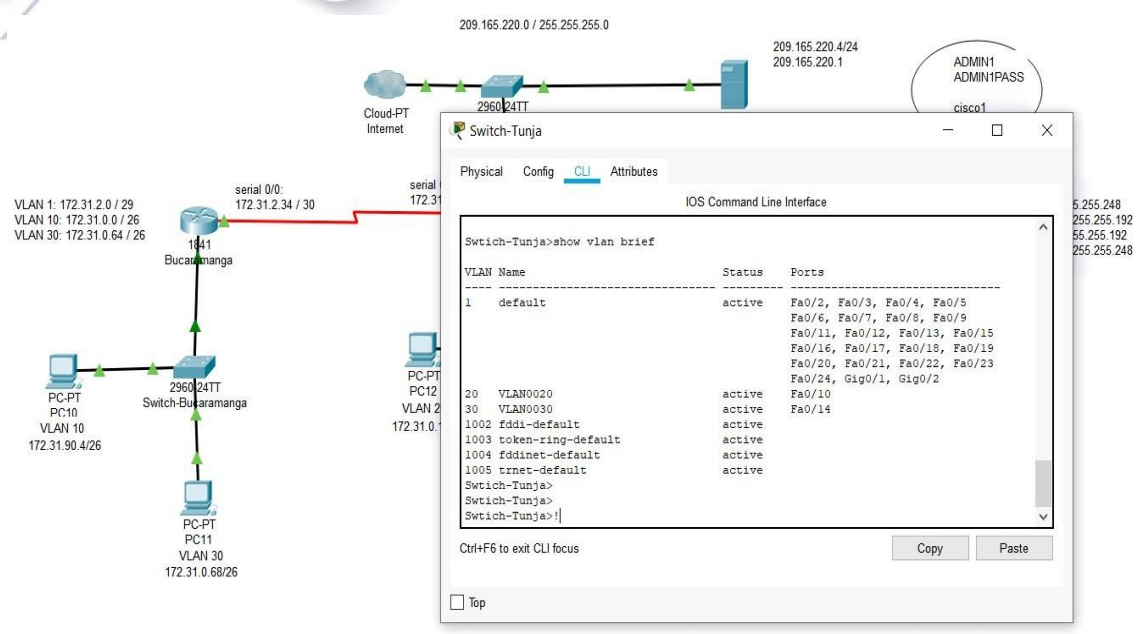

Podemos verificar en este punto la configuración de las interfaces ya realizada y además las respectivas tablas de enrutamiento:

Ya en este punto tenemos configurados todas las interfaces de los router y de los switch, debemos verificar lo hecho hasta el momento, vamos a ver la

configuración de las interfaces de cada dispositivo ingresado y vamos a ver las rutas que conoce cada router:

VLAN 1: 172.31.2.0 / 29
VLAN 10: 172.31.0.0 / 26
VLAN 30: 172.31.0.64 / 26

PC-PT PC10
VLAN 10
172.31.90.4/26

PC-PT PC11
VLAN 30
172.31.0.68/26

PC-PT PC12
VLAN 20
172.31.0.130/26

PC-PT PC13
VLAN 30
172.31.0.11

```

Router1
IOS Command Line Interface
bucaramanga>enable
bucaramanga#show ip interface brief
Interface IP-Address OK? Method Status Protocol
FastEthernet0/0 unassigned YES NVRAM up up
FastEthernet0/0.1 172.31.2.1 YES manual up up
FastEthernet0/0.10 172.31.0.1 YES manual up up
FastEthernet0/0.30 unassigned YES unset up up
FastEthernet0/1 unassigned YES NVRAM administratively down down
Serial0/0/0 172.31.2.34 YES manual up up
Serial0/0/1 unassigned YES NVRAM administratively down down
Vlan1 unassigned YES unset administratively down down
bucaramanga#
bucaramanga#show ip route
Codes: C - connected, S - static, I - IGRP, R - RIP, M - mobile, B - BGP
D - EIGRP, EX - EIGRP external, O - OSPF, IA - OSPF inter area
N1 - OSPF NSSA external type 1, N2 - OSPF NSSA external type 2
E1 - OSPF external type 1, E2 - OSPF external type 2, E - EGP
i - IS-IS, L1 - IS-IS level-1, L2 - IS-IS level-2, ia - IS-IS inter area
* - candidate default, U - per-user static route, o - ODR
P - periodic downloaded static route

Gateway of last resort is not set

172.31.0.0/16 is variably subnetted, 3 subnets, 3 masks
C 172.31.0.0/26 is directly connected, FastEthernet0/0.10
C 172.31.2.0/29 is directly connected, FastEthernet0/0.1
C 172.31.2.32/30 is directly connected, Serial0/0/0
bucaramanga#!
    
```

VLAN 1: 172.31.2.0 / 29
VLAN 10: 172.31.0.0 / 26
VLAN 30: 172.31.0.64 / 26

PC-PT PC10
VLAN 10
172.31.90.4/26

PC-PT PC11
VLAN 30
172.31.0.68/26

PC-PT PC12
VLAN 20
172.31.0.130/26

PC-PT PC13
VLAN 30
172.31.0.194/26

```

Router0
IOS Command Line Interface
up
%LINEPROTO-5-UPDOWN: Line protocol on Interface FastEthernet0/0.30, changed state to up
%LINEPROTO-5-UPDOWN: Line protocol on Interface FastEthernet0/1, changed state to up
%LINEPROTO-5-UPDOWN: Line protocol on Interface Serial0/0/1, changed state to up
%LINEPROTO-5-UPDOWN: Line protocol on Interface Serial0/0/0, changed state to up
El Acceso no autorizado est prohibido

tunja>enable
tunja#show ip interface brief
Interface IP-Address OK? Method Status Protocol
FastEthernet0/0 unassigned YES NVRAM up up
FastEthernet0/0.1 172.3.2.9 YES manual up up
FastEthernet0/0.20 172.31.0.129 YES manual up up
FastEthernet0/0.30 172.31.0.193 YES manual up up
FastEthernet0/1 209.165.220.1 YES manual up up
Serial0/0/0 172.31.2.33 YES manual up up
Serial0/0/1 172.31.2.37 YES manual up up
Vlan1 unassigned YES unset administratively down down
tunja#
tunja#!
    
```

The image shows a network diagram and a CLI screenshot. The diagram illustrates a network topology with two routers, Bucaramanga and Tunja, connected via serial links. Bucaramanga is connected to a switch with three VLANs (10, 26, 29) and three PCs (PC10, PC11, PC13). Tunja is connected to a switch with three VLANs (20, 26, 30) and three PCs (PC12, PC13, PC13). The CLI screenshot shows the configuration of the Bucaramanga router, including interface configurations and routing tables.

```

Router2
Physical Config CLI Attributes
IOS Command Line Interface
CUNDINAMARCA#
CUNDINAMARCA#show ip interface brief
Interface IP-Address OK? Method Status Protocol
FastEthernet0/0 unassigned YES NVRAM up up
FastEthernet0/0.1 172.31.2.9 YES manual up up
FastEthernet0/0.20 172.31.1.65 YES manual up up
FastEthernet0/0.30 172.31.1.1 YES manual up up
FastEthernet0/0.88 172.31.2.25 YES manual up up
FastEthernet0/1 unassigned YES NVRAM administratively down down
Serial0/0/0 172.31.2.38 YES manual up up
Serial0/0/1 unassigned YES NVRAM administratively down down
Vlan1 unassigned YES unset administratively down down
CUNDINAMARCA#show ip route
Codes: C - connected, S - static, I - IGRP, R - RIP, M - mobile, B - BGP
D - EIGRP, EX - EIGRP external, O - OSPF, IA - OSPF inter area
N1 - OSPF NSSA external type 1, N2 - OSPF NSSA external type 2
E1 - OSPF external type 1, E2 - OSPF external type 2, E - EGP
I - IS-IS, L1 - IS-IS level-1, L2 - IS-IS level-2, ia - IS-IS inter area
* - candidate default, U - per-user static route, o - ODR
P - periodic downloaded static route

Gateway of last resort is not set

172.31.0.0/16 is variably subnetted, 5 subnets, 3 masks
C 172.31.1.0/26 is directly connected, FastEthernet0/0.30
C 172.31.1.64/26 is directly connected, FastEthernet0/0.20
C 172.31.2.8/29 is directly connected, FastEthernet0/0.1
C 172.31.2.24/29 is directly connected, FastEthernet0/0.88
C 172.31.2.38/30 is directly connected, Serial0/0/0
CUNDINAMARCA#!
    
```

Podemos ver en los resultados obtenidos 2 cosas, primero la configuración de las interfaces de los dispositivos es correcto, y segundo vemos que tienen rutas para las diferentes redes, pero solo las conectadas directamente, esto porque no tenemos configurado aún un protocolo de enrutamiento.

Configuramos el protocolo de enrutamiento en cada uno de los routers

BUCARAMANGA(config-if)#router ospf 1

BUCARAMANGA(config-router)#network 172.31.0.0 0.0.0.63 area 0

BUCARAMANGA(config-router)#network 172.31.0.64 0.0.0.63 area 0

BUCARAMANGA(config-router)#network 172.31.2.0 0.0.0.7 area 0

BUCARAMANGA(config-router)#network 172.31.2.32 0.0.0.3 area 0

BUCARAMANGA(config-router)#end

TUNJA(config-if)#router ospf 1

TUNJA(config-router)#network 172.3.2.8 0.0.0.7 area 0

TUNJA(config-router)#network 172.31.0.128 0.0.0.63 area 0

TUNJA(config-router)#network 172.31.0.192 0.0.0.63 area 0

```
TUNJA(config-router)#network 172.31.2.32 0.0.0.3 area 0
TUNJA(config-router)#network 172.31.2.36 0.0.0.3 area 0
TUNJA(config-router)#end
```

```
CUNDINAMARCA(config-if)#router ospf 1
CUNDINAMARCA(config-router)#network 172.31.1.0 0.0.0.63 area 0
CUNDINAMARCA(config-router)#network 172.31.1.64 0.0.0.63 area 0
CUNDINAMARCA(config-router)#network 172.31.2.8 0.0.0.7 area 0
CUNDINAMARCA(config-router)#network 172.31.2.24 0.0.0.7 area 0
CUNDINAMARCA(config-router)#network 172.31.2.36 0.0.0.3 area 0
CUNDINAMARCA(config-router)#end
```

Podemos ahora verificar que cada uno de los router aprenda las rutas de los demás routers que hacen parte de la red:

Router1

Physical Config **CLI** Attributes

IOS Command Line Interface

```

bucaramanga>enable
bucaramanga#show ip route
Codes: C - connected, S - static, I - IGRP, R - RIP, M - mobile, B - BGP
       D - EIGRP, EX - EIGRP external, O - OSPF, IA - OSPF inter area
       N1 - OSPF NSSA external type 1, N2 - OSPF NSSA external type 2
       E1 - OSPF external type 1, E2 - OSPF external type 2, E - EGP
       i - IS-IS, L1 - IS-IS level-1, L2 - IS-IS level-2, ia - IS-IS inter area
       * - candidate default, U - per-user static route, o - ODR
       P - periodic downloaded static route

Gateway of last resort is not set

 172.3.0.0/29 is subnetted, 1 subnets
O   172.3.2.8 [110/65] via 172.31.2.33, 00:00:38, Serial0/0/0
 172.31.0.0/16 is variably subnetted, 10 subnets, 3 masks
C   172.31.0.0/26 is directly connected, FastEthernet0/0.10
O   172.31.0.128/26 [110/65] via 172.31.2.33, 00:00:38, Serial0/0/0
O   172.31.0.192/26 [110/65] via 172.31.2.33, 00:00:38, Serial0/0/0
O   172.31.1.0/26 [110/129] via 172.31.2.33, 00:00:28, Serial0/0/0
O   172.31.1.64/26 [110/129] via 172.31.2.33, 00:00:28, Serial0/0/0
C   172.31.2.0/29 is directly connected, FastEthernet0/0.1
O   172.31.2.8/29 [110/129] via 172.31.2.33, 00:00:28, Serial0/0/0
O   172.31.2.24/29 [110/129] via 172.31.2.33, 00:00:28, Serial0/0/0
C   172.31.2.32/30 is directly connected, Serial0/0/0
O   172.31.2.36/30 [110/128] via 172.31.2.33, 00:00:38, Serial0/0/0

bucaramanga#!
  
```

Ctrl+F6 to exit CLI focus

Copy Paste

Top

Router0

Physical Config **CLI** Attributes

IOS Command Line Interface

```

tunja>enable
tunja#show ip route
Codes: C - connected, S - static, I - IGRP, R - RIP, M - mobile, B - BGP
       D - EIGRP, EX - EIGRP external, O - OSPF, IA - OSPF inter area
       N1 - OSPF NSSA external type 1, N2 - OSPF NSSA external type 2
       E1 - OSPF external type 1, E2 - OSPF external type 2, E - EGP
       i - IS-IS, L1 - IS-IS level-1, L2 - IS-IS level-2, ia - IS-IS inter area
       * - candidate default, U - per-user static route, o - ODR
       P - periodic downloaded static route

Gateway of last resort is not set

 172.3.0.0/29 is subnetted, 1 subnets
C   172.3.2.8 is directly connected, FastEthernet0/0.1
 172.31.0.0/16 is variably subnetted, 10 subnets, 3 masks
O   172.31.0.0/26 [110/65] via 172.31.2.34, 00:00:49, Serial0/0/0
C   172.31.0.128/26 is directly connected, FastEthernet0/0.20
C   172.31.0.192/26 is directly connected, FastEthernet0/0.30
O   172.31.1.0/26 [110/65] via 172.31.2.38, 00:00:49, Serial0/0/1
O   172.31.1.64/26 [110/65] via 172.31.2.38, 00:00:49, Serial0/0/1
O   172.31.2.0/29 [110/65] via 172.31.2.34, 00:00:49, Serial0/0/0
O   172.31.2.8/29 [110/65] via 172.31.2.38, 00:00:49, Serial0/0/1
O   172.31.2.24/29 [110/65] via 172.31.2.38, 00:00:49, Serial0/0/1
C   172.31.2.32/30 is directly connected, Serial0/0/0
C   172.31.2.36/30 is directly connected, Serial0/0/1
C   209.165.220.0/24 is directly connected, FastEthernet0/1

tunja#!
  
```

Ctrl+F6 to exit CLI focus

Copy Paste

Top

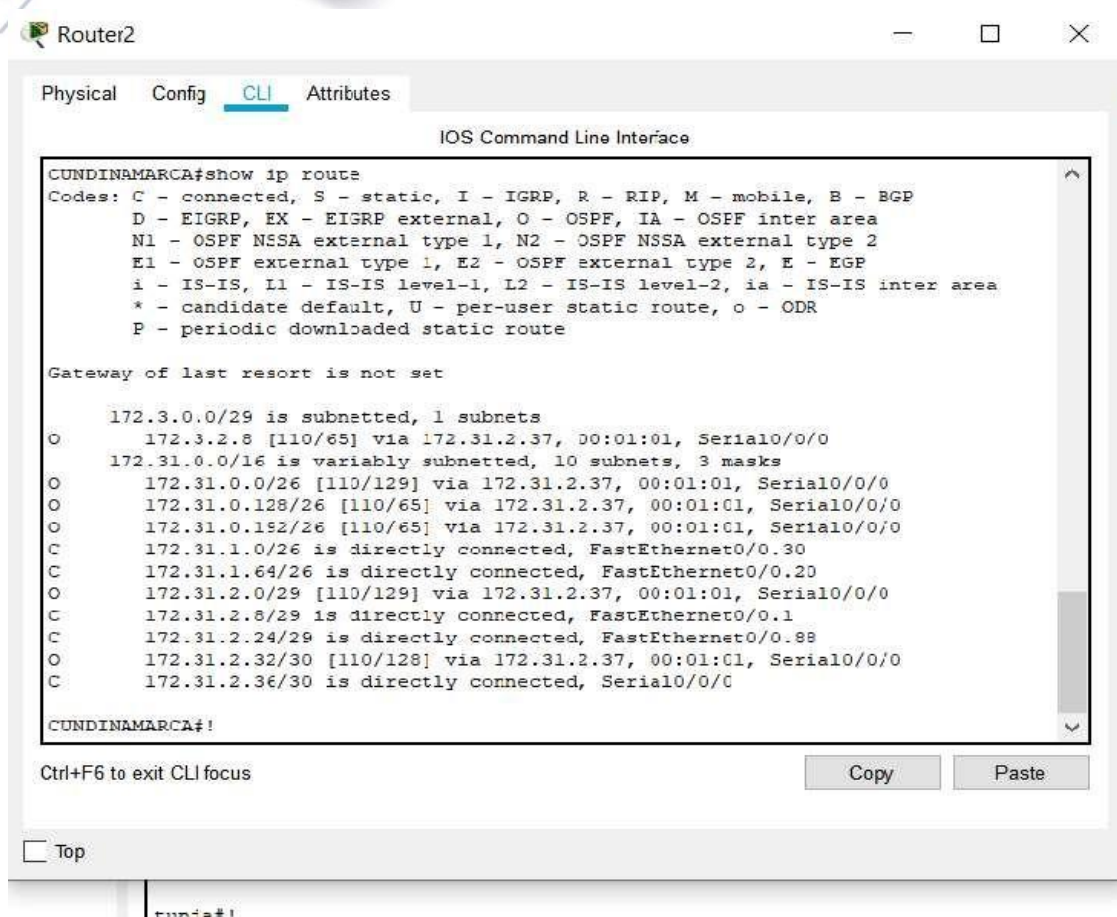

- **Autenticación local con AAA.**

Configuramos la autenticación AAA en cada uno de los routers y la aplicamos a las líneas de consola y vty.

```

BUCARAMANGA(config-line)#username ADMIN1 secret ADMIN1PASS
BUCARAMANGA(config)#aaa new-model
BUCARAMANGA(config)#aaa authentication login aaalocal local
BUCARAMANGA(config)#line console 0
BUCARAMANGA(config-line)#login authentication aaalocal
BUCARAMANGA(config-line)#line vty 0 15
  
```

BUCARAMANGA(config-line)#login authentication aaalocal

TUNJA(config-line)#username ADMIN1 secret ADMIN1PASS

TUNJA(config)#aaa new-model

TUNJA(config)#aaa authentication login aaalocal local

TUNJA(config)#line console 0

TUNJA(config-line)#login authentication aaalocal

TUNJA(config-line)#line vty 0 15

TUNJA(config-line)#login authentication aaalocal

CUNDINAMARCA(config-line)#username ADMIN1 secret ADMIN1PASS

CUNDINAMARCA(config)#aaa new-model

CUNDINAMARCA(config)#aaa authentication login aaalocal local

CUNDINAMARCA(config)#line console 0

CUNDINAMARCA(config-line)#login authentication aaalocal

CUNDINAMARCA(config-line)#line vty 0 15

CUNDINAMARCA(config-line)#login authentication aaalocal

- **Un máximo de internos para acceder al router.**

1. **enable**
2. **configure terminal**
3. **login block-for** *seconds* **attempts** *tries* **within** *seconds*
4. **login quiet-mode access-class** {*acl-name* | *acl-number*}
5. **login delay** *seconds*

- BUCARAMANGA(config-line)#login block-for 20 attempts 10 within 60
- TUNJA(config-line)#login block-for 20 attempts 10 within 60
- CUNDINAMARCA(config-line)#login block-for 20 attempts 10 within 60
- **Establezca un servidor TFTP y almacene todos los archivos necesarios de los routers**

SERVER88

The image shows a network diagram on the left and a configuration window for 'Server88' on the right. The network diagram illustrates a multi-site setup with three routers: Bucaramanga, Tunja, and Cundinamarca. Each router is connected to a 2960 24TT switch, which in turn connects to several PC-PT devices. The Bucaramanga switch is connected to PC-PT PC10 (VLAN 10, 172.31.90.4/26) and PC-PT PC11 (VLAN 30, 172.31.0.68/26). The Tunja switch is connected to PC-PT PC12 (VLAN 20, 172.31.0.130/26) and PC-PT PC13 (VLAN 30, 172.31.0.194/26). The routers are interconnected via serial links (serial 0/0) and connected to a Cloud-PT Internet cloud. The configuration window on the right shows the 'SERVICES' tab for 'Server88'. The 'TFTP' service is enabled (On). A list of files is shown, including various Cisco IOS images and configuration files, such as 'asa842-k8.bin', 'asa923-k8.bin', and 'c1841-advipservicesk9-mz.124-15.T1.bin'. A 'Remove File' button is visible at the bottom right of the file list.

Vemos que nuestro servidor TFTP está configurado y funcionando.

2. El DHCP deberá proporcionar solo direcciones a los hosts de BUCARAMANGA y CUNDINAMARCA.

Vamos a excluir las primeras direcciones IP de cada uno de los rangos antes de asignarlas a los POOL de direcciones que serán asignadas por medio de DHCP.

- TUNJA(config)#ip dhcp excluded-address 172.31.0.1 172.31.0.3
- TUNJA(config)#ip dhcp excluded-address 172.31.0.65 172.31.0.67
- TUNJA(config)#ip dhcp excluded-address 172.31.1.65 172.31.1.67
- TUNJA(config)#ip dhcp excluded-address 172.31.1.1 172.31.1.3

- Ahora ya podemos proceder a configurar y crear los POOL que vamos a emplear, recordemos que padre nuestro caso le vamos a suministrar las IP a las VLAN de BUCARAMANDA y de CUNDINAMARCA, por lo tanto debemos crear 4 POOL diferentes, tal como lo mostramos a continuación, el router encargado de realizar esta asignación va a ser el router de TUNJA:

```
TUNJA(config)#ip dhcp pool vlan10buc
TUNJA(dhcp-config)#network 172.31.0.0 255.255.255.192
TUNJA(dhcp-config)#default-router 172.31.0.1
TUNJA(dhcp-config)#dns-server 8.8.8.8
```

```
TUNJA(dhcp-config)#ip dhcp pool lan30buc
TUNJA(dhcp-config)#network 172.31.0.64 255.255.255.192
TUNJA(dhcp-config)#default-router 172.31.0.65
TUNJA(dhcp-config)#dns-server 8.8.8.8
```

```
TUNJA(dhcp-config)#ip dhcp pool vlan20cun
TUNJA(dhcp-config)#network 172.31.1.64 255.255.255.192
TUNJA(dhcp-config)#default-router 172.31.1.65
TUNJA(dhcp-config)#dns-server 8.8.8.8
```

```
TUNJA(dhcp-config)#ip dhcp pool vlan30cun
TUNJA(dhcp-config)#network 172.31.1.0 255.255.255.192
TUNJA(dhcp-config)#default-router 172.31.1.1
TUNJA(dhcp-config)#dns-server 8.8.8.8
```

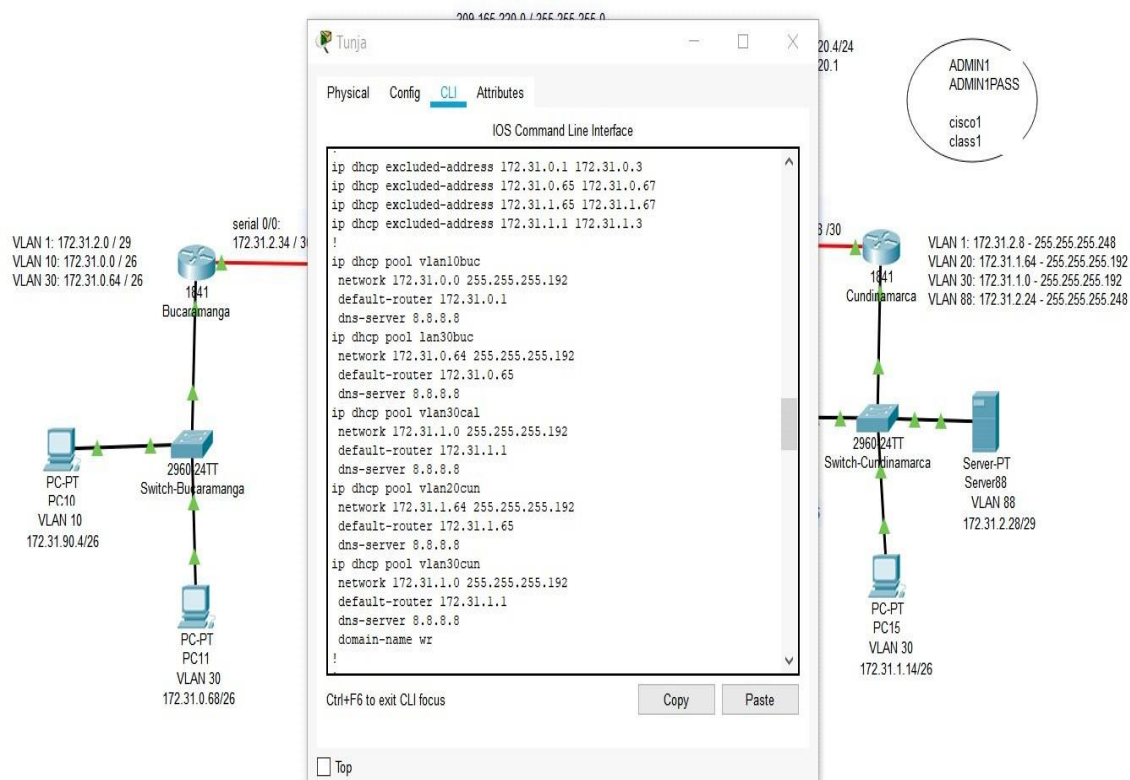

Verificamos la configuración del router de TUNJA.

Ahora debemos configurar los router de CUNDINAMARCA y de TUNJA con el fin de que estos puedan acceder al servicio proporcionado por TUNJA de DHCP.



BUCARAMANGA(config)#int f0/0.10

BUCARAMANGA(config-subif)#ip helper-address 172.31.2.33

BUCARAMANGA(config-subif)#int f0/0.30

BUCARAMANGA(config-subif)#ip helper-address 172.31.2.33

BUCARAMANGA(config-subif)#end

BUCARAMANGA#

CUNDINAMARCA(config)#int f0/0.20

CUNDINAMARCA(config-subif)#ip helper-address 172.31.2.37

CUNDINAMARCA(config-subif)#int f0/0.30

CUNDINAMARCA(config-subif)#ip helper-address 172.31.2.37

CUNDINAMARCA(config-subif)#end

CUNDINAMARCA#

Debemos verificar que los PC obtengan la IP mediante DHCP:

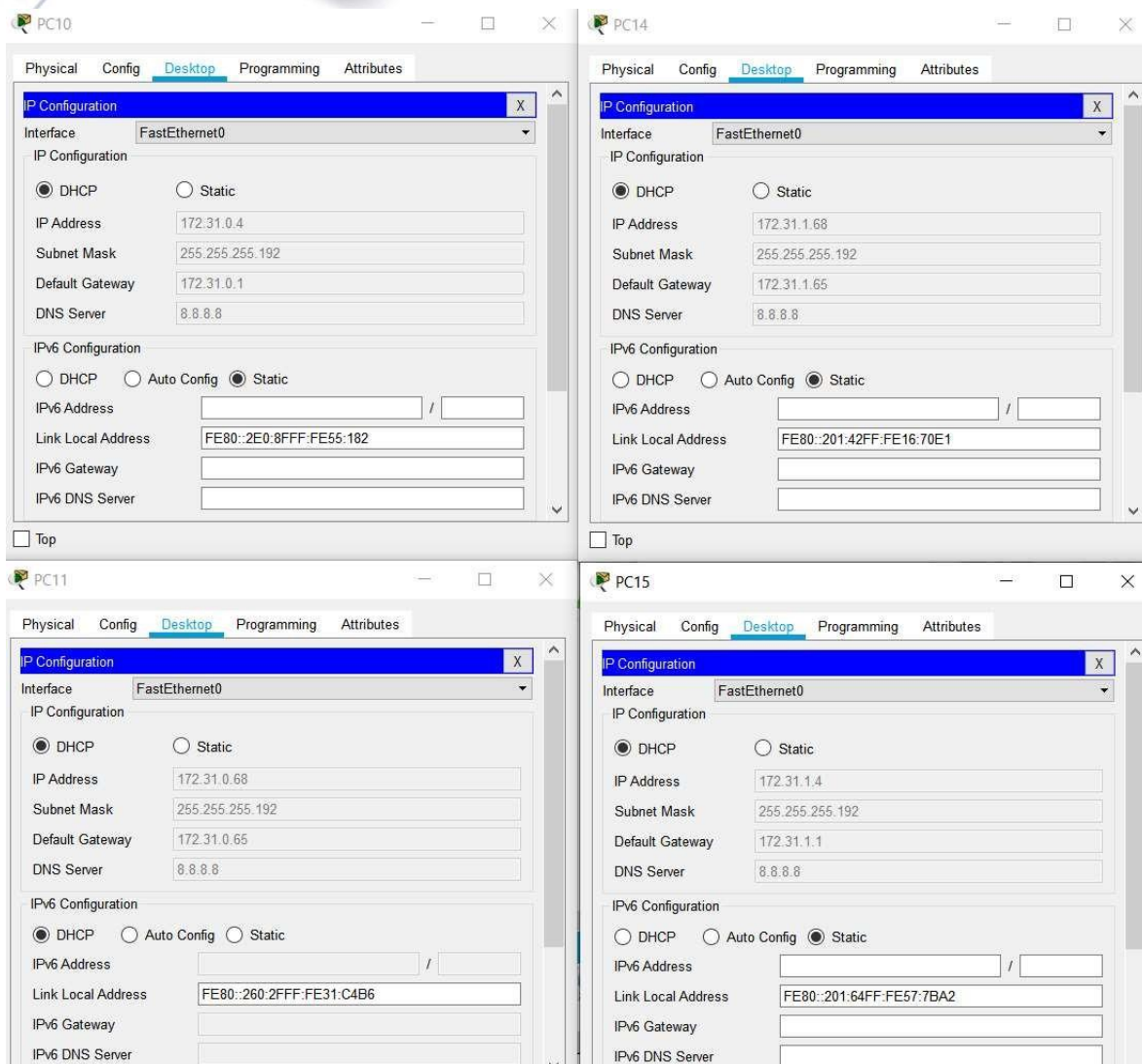

Se observa que las 4 vlan de BUCARAMANDA y CUNDINAMARCA obtienen sus direcciones automáticamente empleando DHCP.

3. El web server deberá tener NAT estático y el resto de los equipos de la topología emplearan NAT de sobrecarga (PAT)

- Asignamos IP NAT STATIC para el servidor:

```

TUNJA(config)#ip nat inside source static 172.31.2.28 209.165.220.10
TUNJA(config)#access-list 11 permit 172.0.0.0 0.255.255.255
TUNJA(config)#ip nat inside source list 11 interface f0/1 overload
TUNJA(config)#int f0/1
TUNJA(config-if)#ip nat outside
TUNJA(config-if)#int f0/0.1
TUNJA(config-subif)#ip nat inside
TUNJA(config-subif)#int f0/0.20
TUNJA(config-subif)#ip nat inside
TUNJA(config-subif)#int f0/0.30
TUNJA(config-subif)#ip nat inside
TUNJA(config-subif)#int s0/0/0
TUNJA(config-if)#ip nat inside
TUNJA(config-if)#int s0/0/1
TUNJA(config-if)#ip nat inside
TUNJA(config-if)#exit

```

- Creamos una ruta por defecto y la distribuimos empleando OSPF.

```

TUNJA(config)#ip route 0.0.0.0 0.0.0.0 209.165.220.4
TUNJA(config)#router ospf 1
TUNJA(config-router)#default-information originate
TUNJA(config-router)#end

```

- Aplicamos SHOW IP ROUTE en los routers con el fin de verificar las nuevas configuraciones y que la ruta por defecto se esté propagando.

```
TUNJA#show ip route
```

Codes: C - connected, S - static, I - IGRP, R - RIP, M - mobile, B - BGP

D - EIGRP, EX - EIGRP external, O - OSPF, IA - OSPF inter area
 N1 - OSPF NSSA external type 1, N2 - OSPF NSSA external type 2
 E1 - OSPF external type 1, E2 - OSPF external type 2, E - EGP
 i - IS-IS, L1 - IS-IS level-1, L2 - IS-IS level-2, ia - IS-IS inter area
 * - candidate default, U - per-user static route, o - ODR
 P - periodic downloaded static route

Gateway of last resort is 209.165.220.4 to network 0.0.0.0

172.3.0.0/29 is subnetted, 1 subnets

C 172.3.2.8 is directly connected, FastEthernet0/0.1

172.31.0.0/16 is variably subnetted, 11 subnets, 3 masks

O 172.31.0.0/26 [110/65] via 172.31.2.34, 00:10:47, Serial0/0/0

O 172.31.0.64/26 [110/65] via 172.31.2.34, 00:10:47, Serial0/0/0

C 172.31.0.128/26 is directly connected, FastEthernet0/0.20

C 172.31.0.192/26 is directly connected, FastEthernet0/0.30

O 172.31.1.0/26 [110/65] via 172.31.2.38, 00:10:47, Serial0/0/1

O 172.31.1.64/26 [110/65] via 172.31.2.38, 00:10:47, Serial0/0/1

O 172.31.2.0/29 [110/65] via 172.31.2.34, 00:10:47, Serial0/0/0

O 172.31.2.8/29 [110/65] via 172.31.2.38, 00:10:47, Serial0/0/1

O 172.31.2.24/29 [110/65] via 172.31.2.38, 00:10:47, Serial0/0/1

C 172.31.2.32/30 is directly connected, Serial0/0/0

C 172.31.2.36/30 is directly connected, Serial0/0/1

C 209.165.220.0/24 is directly connected, FastEthernet0/1

S* 0.0.0.0/0 [1/0] via 209.165.220.4

TUNJA#

BUCARAMANGA#show ip route

Codes: C - connected, S - static, I - IGRP, R - RIP, M - mobile, B - BGP

D - EIGRP, EX - EIGRP external, O - OSPF, IA - OSPF inter area
 N1 - OSPF NSSA external type 1, N2 - OSPF NSSA external type 2
 E1 - OSPF external type 1, E2 - OSPF external type 2, E - EGP
 i - IS-IS, L1 - IS-IS level-1, L2 - IS-IS level-2, ia - IS-IS inter area
 * - candidate default, U - per-user static route, o - ODR
 P - periodic downloaded static route

Gateway of last resort is 172.31.2.33 to network 0.0.0.0

172.3.0.0/29 is subnetted, 1 subnets

O 172.3.2.8 [110/65] via 172.31.2.33, 00:11:18, Serial0/0/0

172.31.0.0/16 is variably subnetted, 11 subnets, 3 masks

C 172.31.0.0/26 is directly connected, FastEthernet0/0.10

C 172.31.0.64/26 is directly connected, FastEthernet0/0.30

O 172.31.0.128/26 [110/65] via 172.31.2.33, 00:11:18, Serial0/0/0

O 172.31.0.192/26 [110/65] via 172.31.2.33, 00:11:18, Serial0/0/0

O 172.31.1.0/26 [110/129] via 172.31.2.33, 00:11:18, Serial0/0/0

O 172.31.1.64/26 [110/129] via 172.31.2.33, 00:11:18, Serial0/0/0

C 172.31.2.0/29 is directly connected, FastEthernet0/0.1

O 172.31.2.8/29 [110/129] via 172.31.2.33, 00:11:18, Serial0/0/0

O 172.31.2.24/29 [110/129] via 172.31.2.33, 00:11:18, Serial0/0/0

C 172.31.2.32/30 is directly connected, Serial0/0/0

O 172.31.2.36/30 [110/128] via 172.31.2.33, 00:11:18, Serial0/0/0

O*E2 0.0.0.0/0 [110/1] via 172.31.2.33, 00:00:51, Serial0/0/0

BUCARAMANGA#

CUNDINAMARCA#show ip route

Codes: C - connected, S - static, I - IGRP, R - RIP, M - mobile, B - BGP

D - EIGRP, EX - EIGRP external, O - OSPF, IA - OSPF inter area

N1 - OSPF NSSA external type 1, N2 - OSPF NSSA external type 2
 E1 - OSPF external type 1, E2 - OSPF external type 2, E - EGP
 i - IS-IS, L1 - IS-IS level-1, L2 - IS-IS level-2, ia - IS-IS inter area
 * - candidate default, U - per-user static route, o - ODR
 P - periodic downloaded static route

Gateway of last resort is 172.31.2.37 to network 0.0.0.0

172.3.0.0/29 is subnetted, 1 subnets

O 172.3.2.8 [110/65] via 172.31.2.37, 00:12:02, Serial0/0/0

172.31.0.0 /16 is variably subnetted, 11 subnets, 3 masks

O 172.31.0.0/26 [110/129] via 172.31.2.37, 00:11:52, Serial0/0/0

O 172.31.0.64/26 [110/129] via 172.31.2.37, 00:11:52, Serial0/0/0

O 172.31.0.128/26 [110/65] via 172.31.2.37, 00:12:02, Serial0/0/0

O 172.31.0.192/26 [110/65] via 172.31.2.37, 00:12:02, Serial0/0/0

C 172.31.1.0/26 is directly connected, FastEthernet0/0.30

C 172.31.1.64/26 is directly connected, FastEthernet0/0.20

O 172.31.2.0/29 [110/129] via 172.31.2.37, 00:11:52, Serial0/0/0

C 172.31.2.8/29 is directly connected, FastEthernet0/0.1

C 172.31.2.24/29 is directly connected, FastEthernet0/0.88

O 172.31.2.32/30 [110/128] via 172.31.2.37, 00:12:02, Serial0/0/0

C 172.31.2.36/30 is directly connected, Serial0/0/0

O*E2 0.0.0.0/0 [110/1] via 172.31.2.37, 00:01:34, Serial0/0/0

CUNDINAMARCA#

Vemos que todos los routers cuentan con la ruta por defecto.

ROUTERO0

Procedemos a verificar que la traducción de direcciones IP se este llevando a cabo.

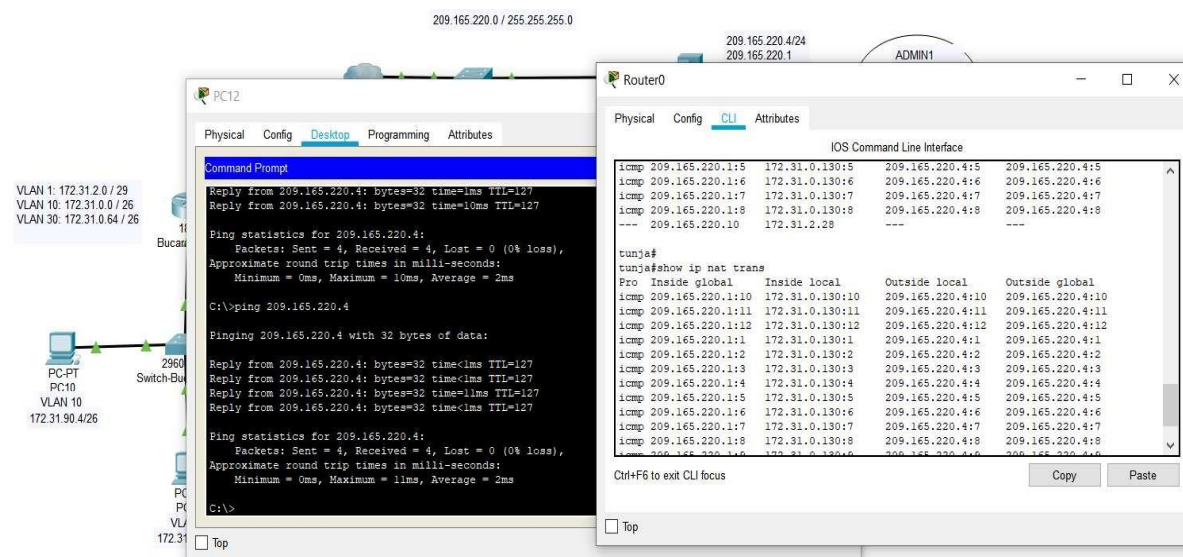

4. El enrutamiento deberá tener autenticación

BUCARAMANGA(config)#int s0/0/0

BUCARAMANGA(config-if)#ip ospf authentication message-digest

BUCARAMANGA(config-if)#ip ospf message-digest-key 1 md5 ospfpass

TUNJA(config)#int s0/0/0

TUNJA(config-if)#ip ospf authentication message-digest

TUNJA(config-if)#ip ospf message-digest-key 1 md5 ospfpass

TUNJA(config-if)#int s0/0/1

TUNJA(config-if)#ip ospf authentication message-digest

TUNJA(config-if)#ip ospf message-digest-key 1 md5 ospfpass

CUNDINAMARCA(config)#int s0/0/0

```
CUNDINAMARCA(config-if)#ip ospf authentication message-digest
CUNDINAMARCA(config-if)#ip ospf message-digest-key 1 md5 ospfpass
CUNDINAMARCA(config-if)#
```

5. Listas de control de acceso

6. Los hosts de VLAN 20 en CUNDINAMARCA no acceden a internet, solo a la red interna de TUNJA.

```
CUNDINAMARCA(config-if)#access-list 151 deny ip 172.31.1.64 0.0.0.63 209.165.220.0
0.0.0.255
CUNDINAMARCA(config)#access-list 151 permit ip any any
CUNDINAMARCA(config)#int f0/0.20
CUNDINAMARCA(config-subif)#ip access-group 151 in
CUNDINAMARCA(config-subif)#
```

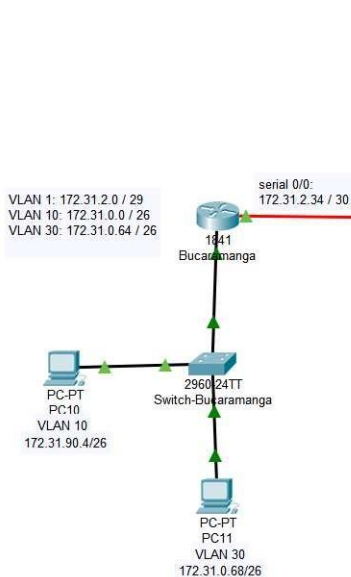

```
209.165.220.0 / 255.255.255.0
209.165.220.4/24
PC14
Physical Config Desktop Programming Attributes
Command Prompt
Invalid Command.
C:\>ping 172.31.0.130
Pinging 172.31.0.130 with 32 bytes of data:
Request timed out.
Reply from 172.31.0.130: bytes=32 time=1ms TTL=126
Reply from 172.31.0.130: bytes=32 time=1ms TTL=126
Reply from 172.31.0.130: bytes=32 time=1ms TTL=126
Ping statistics for 172.31.0.130:
    Packets: Sent = 4, Received = 3, Lost = 1 (25% loss),
    Approximate round trip times in milli-seconds:
        Minimum = 1ms, Maximum = 1ms, Average = 1ms
C:\>ping 209.165.220.4
Pinging 209.165.220.4 with 32 bytes of data:
Reply from 172.31.1.65: Destination host unreachable.
Reply from 172.31.1.65: Destination host unreachable.
Reply from 172.31.1.65: Destination host unreachable.
Reply from 172.31.1.65: Destination host unreachable.
Ping statistics for 209.165.220.4:
    Packets: Sent = 4, Received = 0, Lost = 4 (100% loss),
C:\>|
Top
```

La ACL creada esta cumpliendo con su cometido

Los hosts de VLAN 10 en CUNDINAMARCA si acceden a internet y no a la red interna de TUNJA.

```
CUNDINAMARCA(config-subif)#access-list 152 permit ip 172.31.1.0 0.0.0.63 209.165.220.0 0.0.0.255
```

```
CUNDINAMARCA(config)#access-list 152 deny ip any any
```

```
CUNDINAMARCA(config)#int f0/0.30
```

```
CUNDINAMARCA(config-subif)#ip access-group 152 in
```

```
CUNDINAMARCA(config-subif)#
```

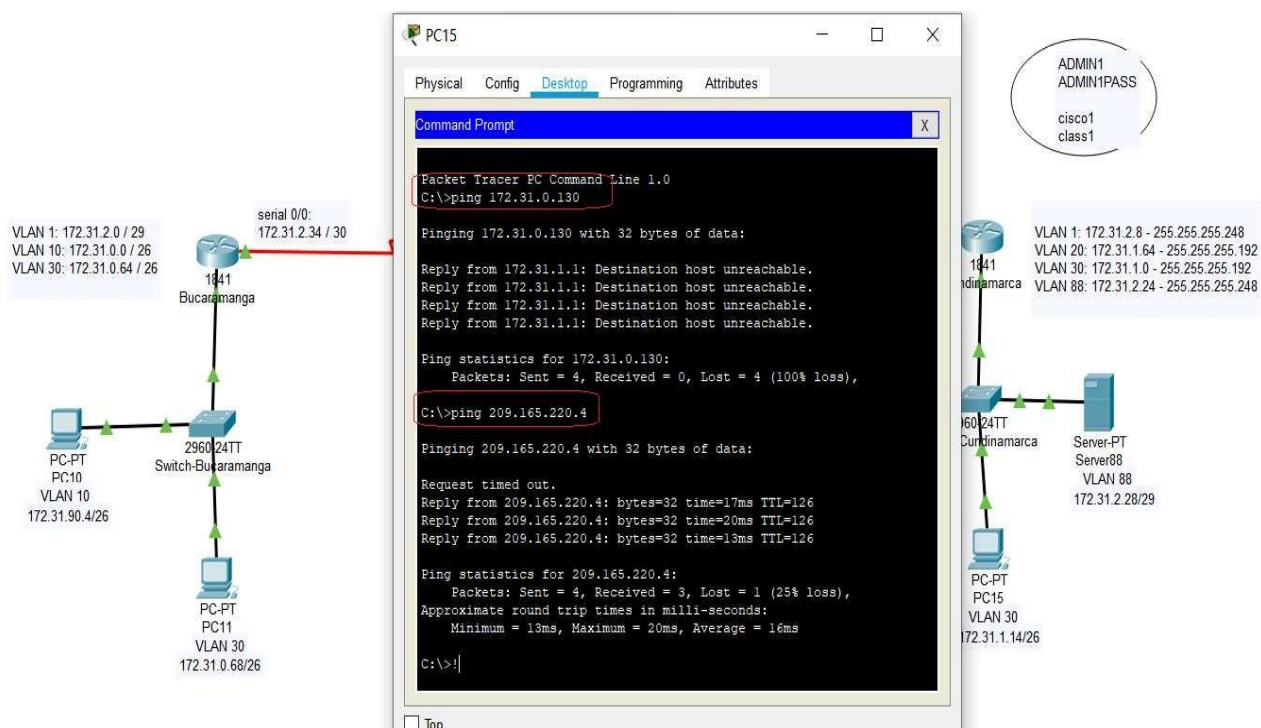

Los hosts de VLAN 30 en TUNJA solo acceden a servidores web y ftp de internet.

```
TUNJA(config)#access-list 151 permit tcp 172.31.0.192 0.0.0.63 209.165.220.0 0.0.0.255 eq www
```

```
TUNJA(config)#access-list 151 permit tcp 172.31.0.192 0.0.0.63 209.165.220.0 0.0.0.255 eq ftp
```

```
TUNJA(config)#int f0/0.30
```

```
TUNJA(config-subif)#ip access-group 151 in
```

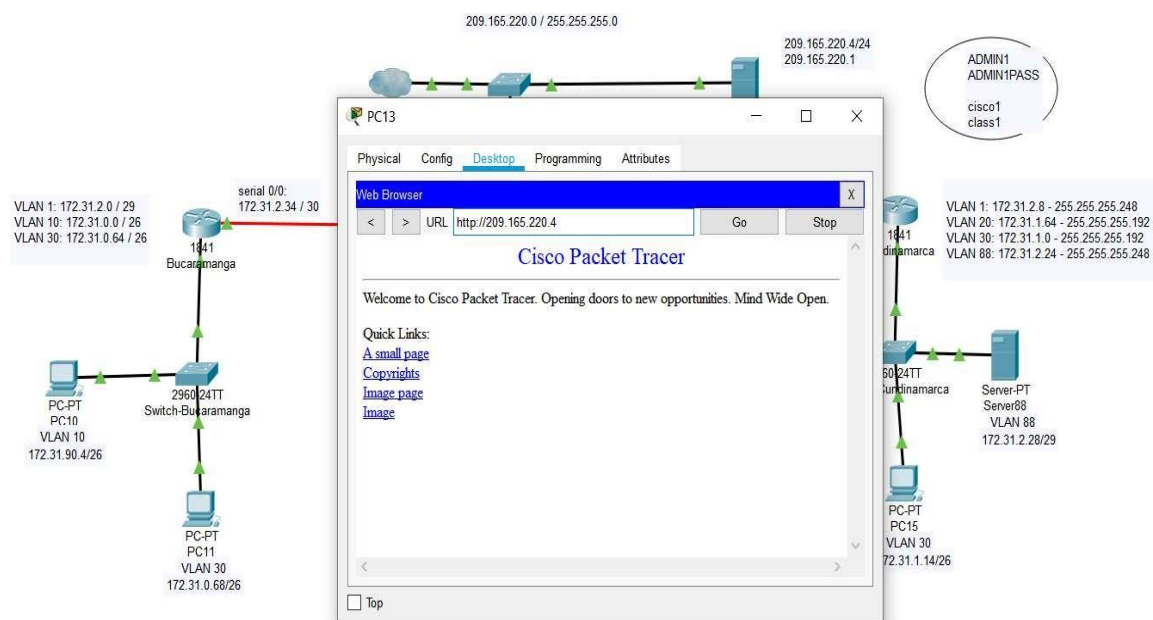
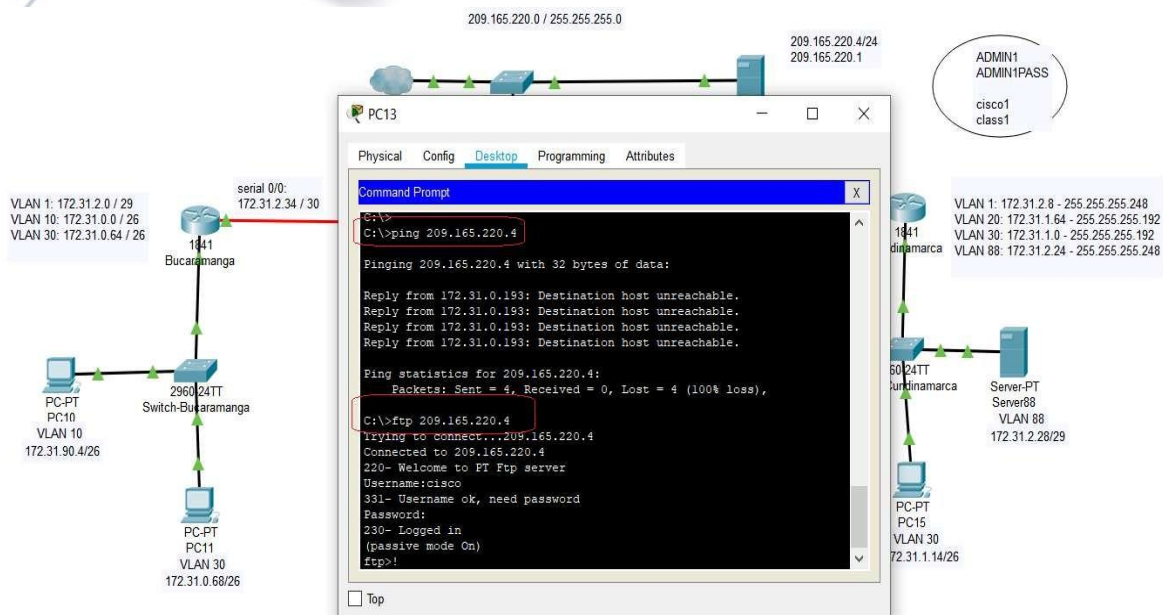

Los hosts de VLAN 20 en TUNJA solo acceden a la VLAN 20 de CUNDINAMARCA y VLAN 10 de BUCARAMANGA.

TUNJA(config-subif)#access-list 152 permit ip 172.31.0.128 0.0.0.63 172.31.1.64 0.0.0.63

TUNJA(config)#access-list 152 permit ip 172.31.0.128 0.0.0.63 172.31.0.0 0.0.0.63

TUNJA(config)#int f0/0.20

```
TUNJA(config-subif)#ip access-group 152 in
TUNJA(config-subif)#
```

PC12

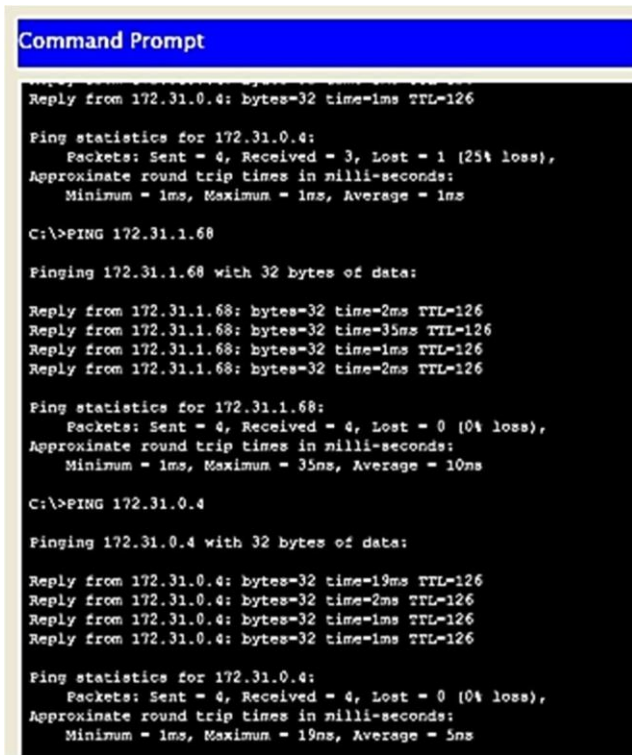

```

Command Prompt

Reply from 172.31.0.4: bytes=32 time=1ms TTL=126

Ping statistics for 172.31.0.4:
    Packets: Sent = 4, Received = 3, Lost = 1 (25% loss),
    Approximate round trip times in milli-seconds:
        Minimum = 1ms, Maximum = 1ms, Average = 1ms

C:\>PING 172.31.1.68

Pinging 172.31.1.68 with 32 bytes of data:

Reply from 172.31.1.68: bytes=32 time=2ms TTL=126
Reply from 172.31.1.68: bytes=32 time=35ms TTL=126
Reply from 172.31.1.68: bytes=32 time=1ms TTL=126
Reply from 172.31.1.68: bytes=32 time=2ms TTL=126

Ping statistics for 172.31.1.68:
    Packets: Sent = 4, Received = 4, Lost = 0 (0% loss),
    Approximate round trip times in milli-seconds:
        Minimum = 1ms, Maximum = 35ms, Average = 10ms

C:\>PING 172.31.0.4

Pinging 172.31.0.4 with 32 bytes of data:

Reply from 172.31.0.4: bytes=32 time=19ms TTL=126
Reply from 172.31.0.4: bytes=32 time=2ms TTL=126
Reply from 172.31.0.4: bytes=32 time=1ms TTL=126
Reply from 172.31.0.4: bytes=32 time=1ms TTL=126

Ping statistics for 172.31.0.4:
    Packets: Sent = 4, Received = 4, Lost = 0 (0% loss),
    Approximate round trip times in milli-seconds:
        Minimum = 1ms, Maximum = 19ms, Average = 5ms

```

Los hosts de VLAN 30 de BUCARAMANGA acceden a internet y a cualquier equipo de VLAN 10.

```
BUCARAMANGA(config)#access-list 151 permit ip 172.31.0.64 0.0.0.63 209.165.220.0
0.0.0.255
BUCARAMANGA(config)#int f0/0.30
BUCARAMANGA(config-subif)#ip access-group 151 in
BUCARAMANGA(config-subif)#
```

PC10

```

Command Prompt

Packet Tracer PC Command Line 1.0
C:\>PING 172.31.1.68

Pinging 172.31.1.68 with 32 bytes of data:

Request timed out.
Reply from 172.31.1.68: bytes=32 time=2ms TTL=125
Reply from 172.31.1.68: bytes=32 time=4ms TTL=125
Reply from 172.31.1.68: bytes=32 time=5ms TTL=125

Ping statistics for 172.31.1.68:
    Packets: Sent = 4, Received = 3, Lost = 1 (25% loss),
    Approximate round trip times in milli-seconds:
        Minimum = 2ms, Maximum = 5ms, Average = 3ms

C:\>PING 172.31.0.130

Pinging 172.31.0.130 with 32 bytes of data:

Request timed out.
Reply from 172.31.0.130: bytes=32 time=1ms TTL=126
Reply from 172.31.0.130: bytes=32 time=21ms TTL=126
Reply from 172.31.0.130: bytes=32 time=1ms TTL=126

Ping statistics for 172.31.0.130:
    Packets: Sent = 4, Received = 3, Lost = 1 (25% loss),
    Approximate round trip times in milli-seconds:
        Minimum = 1ms, Maximum = 21ms, Average = 7ms

C:\>PING 209.165.220.4

Pinging 209.165.220.4 with 32 bytes of data:

Reply from 172.31.0.1: Destination host unreachable.
Reply from 172.31.0.1: Destination host unreachable.
Reply from 172.31.0.1: Destination host unreachable.
Reply from 172.31.0.1: Destination host unreachable.

Ping statistics for 209.165.220.4:
    Packets: Sent = 4, Received = 0, Lost = 4 (100% loss),

C:\>^
    
```

- Los hosts de una VLAN no pueden acceder a los de otra VLAN en una ciudad.

```
BUCARAMANGA(config-subif)#access-list 153 deny ip 172.31.2.0 0.0.0.7 172.31.0.0
0.0.0.63
```

```
BUCARAMANGA(config)#access-list 153 deny ip 172.31.0.64 0.0.0.63 172.31.0.0
0.0.0.63
```

```
BUCARAMANGA(config)#access-list 153 permit ip any any
```

```
BUCARAMANGA(config)#int f0/0.10
```

```
BUCARAMANGA(config-subif)#ip access-group 153 out
```

```
TUNJA(config)#access-list 153 deny ip 172.3.2.8 0.0.0.7 172.31.0.128 0.0.0.63
TUNJA(config)#access-list 153 deny ip 172.3.0.192 0.0.0.63 172.31.0.128 0.0.0.63
TUNJA(config)#access-list 153 permit ip any any
TUNJA(config)#int f0/0.20
TUNJA(config-subif)#ip access-group 153 out
```

```
CUNDINAMARCA(config)#access-list 153 deny ip 172.31.2.8 0.0.0.7 172.31.1.64
0.0.0.63
CUNDINAMARCA(config)#access-list 153 deny ip 172.31.1.0 0.0.0.63 172.31.1.64
0.0.0.63
CUNDINAMARCA(config)#access-list 153 deny ip 172.31.2.24 0.0.0.7 172.31.1.64
0.0.0.63
CUNDINAMARCA(config)#access-list 153 permit ip any any
CUNDINAMARCA(config)#int f0/0.20
CUNDINAMARCA(config-subif)#ip access-group 153 out
```

PC12

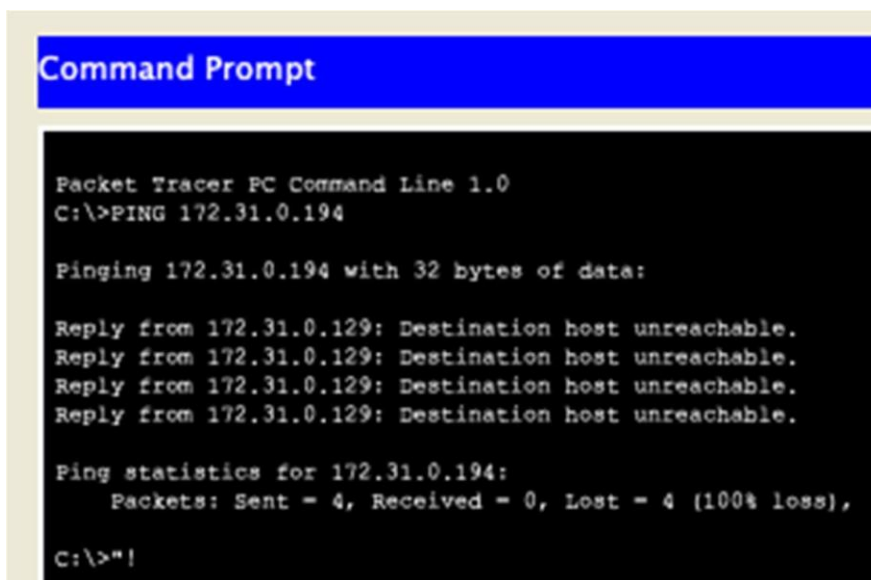

```
Command Prompt

Packet Tracer PC Command Line 1.0
C:\>PING 172.31.0.194

Pinging 172.31.0.194 with 32 bytes of data:

Reply from 172.31.0.129: Destination host unreachable.
Reply from 172.31.0.129: Destination host unreachable.
Reply from 172.31.0.129: Destination host unreachable.
Reply from 172.31.0.129: Destination host unreachable.

Ping statistics for 172.31.0.194:
    Packets: Sent = 4, Received = 0, Lost = 4 (100% loss),

C:\>!
```

PC10

```

Command Prompt

Packet Tracer PC Command Line 1.0
C:\>PING 172.31.0.68

Pinging 172.31.0.68 with 32 bytes of data:

Reply from 172.31.0.1: Destination host unreachable.
Reply from 172.31.0.1: Destination host unreachable.
Reply from 172.31.0.1: Destination host unreachable.
Reply from 172.31.0.1: Destination host unreachable.

Ping statistics for 172.31.0.68:
    Packets: Sent = 4, Received = 0, Lost = 4 (100% loss),

C:\>

```

Solo los hosts de las VLAN administrativas y de la VLAN de servidores tienen acceso a los routers e internet.

```
BUCARAMANGA(config-subif)#access-list 10 permit 172.31.2.0 0.0.0.7
```

```
BUCARAMANGA(config)#access-list 10 permit 172.3.2.8 0.0.0.7
```

```
BUCARAMANGA(config)#access-list 10 permit 172.31.2.8 0.0.0.7
```

```
BUCARAMANGA(config)#line vty 0 15
```

```
BUCARAMANGA(config-line)#access-class 10 in
```

```
BUCARAMANGA(config-line)#
```

```
TUNJA(config-subif)#access-list 10 permit 172.31.2.0 0.0.0.7
```

```
TUNJA(config)#access-list 10 permit 172.3.2.8 0.0.0.7
```

```
TUNJA(config)#access-list 10 permit 172.31.2.8 0.0.0.7
```

```
TUNJA(config)#line vty 0 15
```

```
TUNJA(config-line)#access-class 10 in
```

```
TUNJA(config-line)#
```

```

CUNDINAMARCA(config-subif)#access-list 10 permit 172.31.2.0 0.0.0.7
CUNDINAMARCA(config)#access-list 10 permit 172.3.2.8 0.0.0.7
CUNDINAMARCA(config)#access-list 10 permit 172.31.2.8 0.0.0.7
CUNDINAMARCA(config)#line vty 0 15
CUNDINAMARCA(config-line)#access-class 10 in
CUNDINAMARCA(config-line)#
  
```

SWITCH1

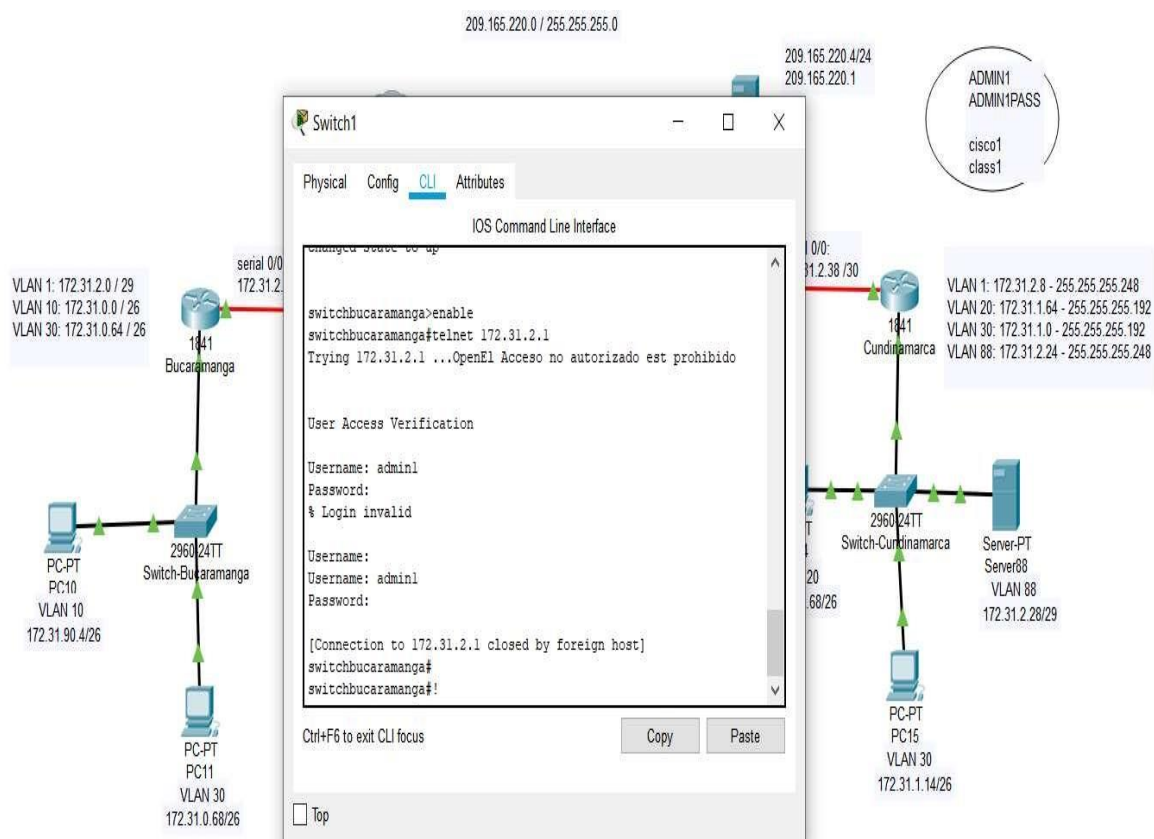

SWITCH2

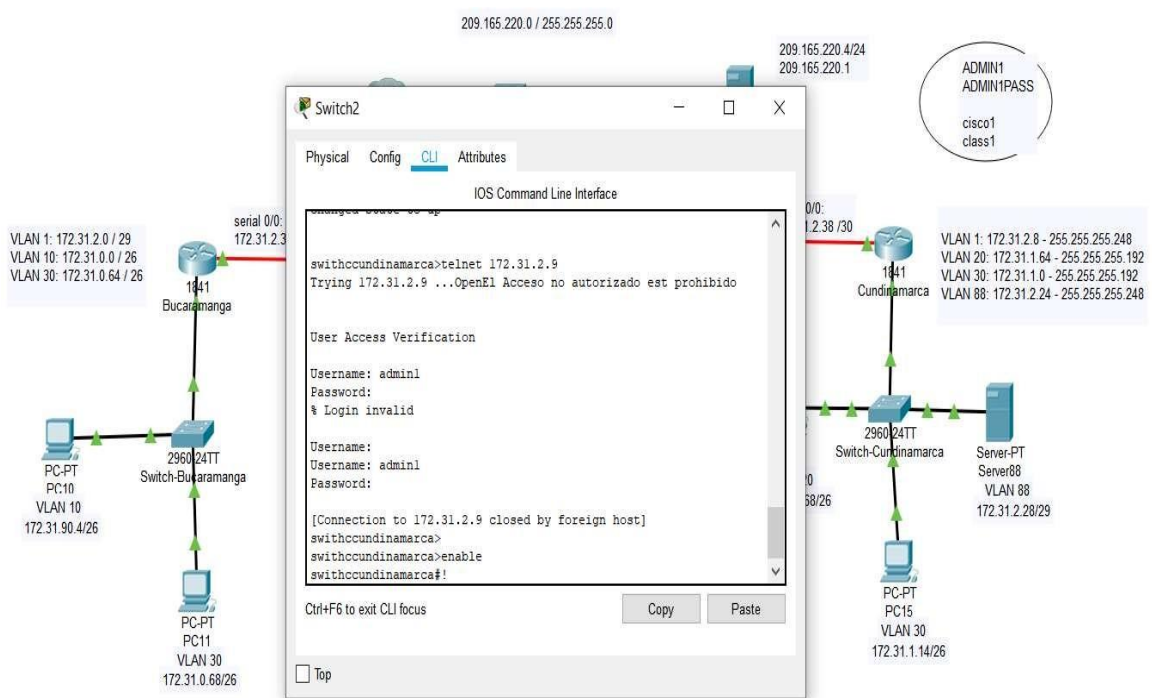

CONCLUSIONES

En base a los conocimientos adquiridos durante el desarrollo del diplomando y del periodo del curso CCNA1 y CCNA2 se fueron manejando destrezas y/o competencia para poder abordar el desarrollo de esta práctica de habilidades finales.

Este tipo de ejercicios nos enfrentan a una serie de problemas que para nosotros como estudiantes que aún no tenemos tanta habilidad para detectar dónde está el verdadero error nos, puede desanimar ante la impotencia de no encontrar la manera correcta de sobrepasar el impase, una vez logramos superar esos errores se siente una sensación de victoria por no haberse rendido ante la adversidad.

La ayuda por parte de los módulos, simulaciones y tutores son de vital importancia para poder hacer bases para abarcar estas situaciones dentro de la administración de las redes, la motivación por parte de los tutores nos lleva a intentar miles de veces en caso de ser necesario hasta aprobar.

OSPF es un protocolo de enrutamiento sin clase que utiliza el concepto de áreas para realizar la escalabilidad OSPF (Abrir el camino más corto en español) es la traducción de sus siglas, que utiliza el algoritmo Dijkstra para poder encontrar el camino más corto entre dos punto o nodos.

NAT (Network Address Translation) también llamado enmascaramiento de IP, tiene muchos usos, pero el principal es conservar las direcciones IPv4 públicas. NAT consiste en utilizar una conexión de pasarela a Internet, que tenga al menos una interfaz de red conectada a la red interna y al menos una interfaz de red conectada a Internet, para lograr conectar todos los equipos a una red.

El principio de NAT estática consiste en vincular una dirección IP pública con una dirección IP interna privada en la red.

BIBLIOGRAFÍA

Tutoriales Packet Tracer José Pablo Ullate e, Comandos Básicos, ARRANQUE DEL ROUTER

https://docs.google.com/viewer?a=v&pid=sites&srcid=ZGVmYXVsdGRvbWFpbntb2Q_yY2NuYXxneDo3YWJkZGQ4ZGZmZTdmNDY0

NEWFLY, REDES CISCO Y PACKET TRACER, VIDEOS MODULO 2 COMANDOS BÁSICOS ROUTER CISCO PACKET TRACER TUTORIAL 4
<https://youtu.be/la2arQe6Kkg>

EL ROUTER DIRECCIONAMIENTO IP

<https://youtu.be/rhUTmcMOtNw>

CISCO. (2014). Introducción a redes conmutadas. Principios de Enrutamiento y Conmutación. Recuperado de <https://static-course-assets.s3.amazonaws.com/RSE50ES/module1>

CISCO. (2014). VLANs. Principios de Enrutamiento y Conmutación. Recuperado de <https://static-course-assets.s3.amazonaws.com/RSE50ES/module3/index.html#3.0.1.1/index.html#1.0.1.1>

Vesga, J. (2014). Configuración de Switches y Routers [OVA]. Recuperado de <https://1drv.ms/u/s!AmIJYei-NT1lhqL9QChD1m9EuGqC>