

DIPLOMADO DE PROFUNDIZACION CISCO
PRUEBA DE HABILIDADES PRACTICAS CCNP

JOHAN SNEYDER SANTAMARIA ARIZA

UNIVERSIDAD NACIONAL ABIERTA Y A DISTANCIA – UNAD
ESCUELA DE CIENCIAS BÁSICAS, TECNOLOGÍA E INGENIERÍA -
ECBTI INGENIERÍA TELECOMUNICACIONES
BOGOTA
2023

DIPLOMADO DE PROFUNDIZACION CISCO
PRUEBA DE HABILIDADES PRACTICAS CCNP

JOHAN SNEYDER SANTAMARIA ARIZA

Diplomado de opción de grado presentado para optar el
título de INGENIERO TELECOMUNICACIONES

DIRECTOR:
JHON HAROLD PEREZ CALDERON

UNIVERSIDAD NACIONAL ABIERTA Y A DISTANCIA – UNAD
ESCUELA DE CIENCIAS BÁSICAS, TECNOLOGÍA E INGENIERÍA -
ECBTI INGENIERÍA TELECOMUNICACIONES
BOGOTA
2023

NOTA DE ACEPTACIÓN

Firma del presidente del Jurado

Firma del Jurado

Firma del Jurado

BOGOTA, 4 de mayo de 2023

AGRADECIMIENTOS

Agradezco a Dios por la oportunidad de poder obtener la salud, recursos, constancia y disciplina para poder cursar y culminar la ingeniería de telecomunicaciones, a mi familia por el apoyo que me han brindado a lo largo de esta carrera, del mismo modo agradezco inmensamente a los tutores y docentes, pues han sido pilar y parte clave en nuestro proceso de aprendizaje brindándonos herramientas de una alta calidad de de en diferentes competencias y habilidades.

CONTENIDO

AGRADECIMIENTOS	4
CONTENIDO.....	5
LISTA DE FIGURAS	7
GLOSARIO	9
RESUMEN	10
ABSTRACT	11
INTRODUCCION	12
1. Escenario Propuesto	13
1.1 Tabla Direcciones equipos	14
2. Escenario realizado GNS3	15
2.1 Topología escenario diseño GNS3	16
3. Configuración ajustes básicos para cada dispositivo	17
3.1 Guardar las configuraciones en cada uno de los dispositivos	18
3.2 Configuración PC1, PC2, PC3 y PC4 de acuerdo con la tabla de direccionamiento	19
4. Configuración VRF y enrutamiento estático	21
4.1 Configuración VRF-Lite	21
4.2 Configuración interfaces IPV4 e IPV6 en VRF	24
4.3 configuración rutas estáticas VRF IPV E IPV6 en VRF	27
4.4 verificación conectividad VRF desde R1 a R3.....	28
5. Configuración Capa.....	30
5.1 Apagado Interfaces D1,D2 y A1	30
5.2 Configuración troncal enlace D1 y D2	32
5.3 Configuración interfaz canal puerto PAgP D1 y A1	33
5.4 Configuración y habilitación puertos VLAN D1 D2 A1	35

5.5 Validación Conexión PC1 A PC2 - PC3 A PC4	38
6. Configuración seguridad	39
6.1 Configuración clave secreta R1, R2, R3, D1, D2 y A1	39
6.2 Configuración usuario local R1, R2, R3, D1, D2 y A1	40
6.3 Habilitación autenticación base de datos local R1, R2, R3, D1, D2 y A1	40
7. Conclusiones.....	43
8. Bibliografía	44

LISTA DE FIGURAS

Figura 1. Escenario propuesto1	13
Figura 2. Simulación de escenario1	15
Figura 3. Topología escenario diseño GNS3	16
Figura 4. IP – PC1	19
Figura 5. IP – PC2	20
Figura 6. IP – PC3	20
Figura 7. IP – PC4	21
Figura 8. Validación VRF Router1	22
Figura 9. Validación VRF Router2	23
Figura 10. Validación VRF Router3	23
Figura 11. Validación conectividad VRF	28
Figura 12. Validación conectividad VRF	28
Figura 13. Validación conectividad VRF	29
Figura 14. Validación conectividad VRF	29
Figura 15. Apagado Interfaz D1	30
Figura 16. Apagado Interfaz D2	30
Figura 17. Apagado Interfaz A1	31
Figura 18. Configuración troncal enlace D1	32
Figura 19. Configuración troncal enlace D2	33

LISTA DE FIGURAS

Figura 20. Configuración puerto PAgP D1_____	34
Figura 21. Configuración puerto PAgP A2_____	35
Figura 22. Configuración puertos accesos D1_____	36
Figura 23. Configuración puertos accesos D2_____	37
Figura 24. Configuración puertos accesos A1_____	38
Figura 25. Ping PC1 A PC2 _____	39
Figura 26. Ping PC3 A PC4_____	39
Figura 27. Validación seguridad R1_____	41
Figura 28. Validación seguridad R3_____	41
Figura 29. Validación seguridad R3_____	41
Figura 30. Validación seguridad D1_____	42
Figura 31. Validación seguridad D2_____	42
Figura 32. Validación seguridad A1_____	42

GLOSARIO

CCNP: certificación Cisco Certified Network Professional para la prueba de habilidades para la implementación, planificación, resolver y verificar problemas de

DUPLEX: sistema capaz de mantener una comunicación bidireccional, enviando y recibiendo mensajes de forma simultánea.

GNS3: emulador gráfico de red que permite diseñar topologías de red y poner en marcha simulaciones sobre el mismo.

PING: medida que sirve para la medición de la latencia que corresponde al tiempo que tarda transmitir un paquete de datos dentro de la red.

ROUTER: enrutador o encaminador que permite interconectar redes con distinto prefijo en su dirección IP.

SWITCH: conmutador digital lógico para la interconexión de dispositivos que operen dentro de la capa modelo OSI, enlace de datos.

TOPOLOGIA DE RED: mapa físico lógico en una red para el intercambio de datos sea en el plano físico o lógico

VRF: permite que varias instancias de una tabla de enrutamiento coexistan en el router al mismo tiempo.
redes locales.

VLAN: permite dividir la red en grupos con una agrupación o estructura jerárquica lógica en un lugar de una física.

RESUMEN

Para la implementación de diseño de redes y la infraestructura que faciliten el desarrollo continuo de metodologías basados en el aprendizaje mediante la aplicación del curso CCNP, se procederá a la realizar la simulación de una topología de red por medio de la herramienta GNS3 permitiendo la comunicación entre cada uno de los dispositivos garantizando la conexión estable y la seguridad principal para el ingreso de los usuarios autorizados a los diferentes equipos relacionados en la topología de redes.

Se aplican los diferentes requerimientos y ajustes necesarios para el correcto funcionamiento de los dispositivos de simulación como lo son routers, switch y PCs, teniendo en cuenta los diferentes conceptos vistos en el transcurso del diplomado para obtener el título de ingeniería.

Palabras Clave: CCNP, Conmutación, Enrutamiento, GNS3, Redes, Topología.

ABSTRACT

The implementation of network design and infrastructure that facilitate the continuous development of methodologies based on learning through the application of the CCNP course the simulation of a network topology will be carried out by means of the GNS3 tool, allowing communication between each of the devices, guaranteeing the stable connection and the main security for the entry of authorized users to the different equipment related to the network. network topology.

The different requirements and adjustments necessary for the proper functioning of the simulation devices such as routers, switches and PCs are applied, taking into account the different concepts seen during the course of the diploma to obtain the engineering degree.

Keywords: CCNP, Switching, Routing, GNS3, Networks, Topology.

INTRODUCCIÓN

El desarrollo del presente trabajo describe a la realización y aplicación de los diferentes conocimientos aprendidos durante el curso de CCNP, adquiridos o durante la práctica, utilizando el emulador de GNS3 para el funcionamiento de la red.

El estudiante procederá al diseño e implementación de una red que cuente con los ajustes necesarios y el direccionamiento en sus interfaces para su correcto funcionamiento, proporcionando los medios y configuraciones aplicadas a cada uno de los dispositivos de red que se busca establecer una comunicación entre ellos.

La configuración VRF con rutas estáticas para la aplicación de seguridad, promoverá las buenas prácticas aplicadas en configuración y proporcionadas en el transcurso del curso verificando que se apliquen todos los requerimientos solicitados, en la guía de desarrollo para la actividad, teniendo en cuenta la aplicación de las configuraciones, obteniendo como resultado una conexión con los respectivos dispositivos dentro del entorno de red.

De igual manera el desarrollo de la presente actividad busca realizar un aporte a la población que involucre todos los procedimientos descritos anteriormente y que puedan ser utilizados en su vida cotidiana, académica o profesional.

DESARROLLO

1. ESCENARIO PROPUESTO



Figura 1. Escenario propuesto

Fuente: CCNA

1.1 Tabla direcciones Equipos

Addressing Table

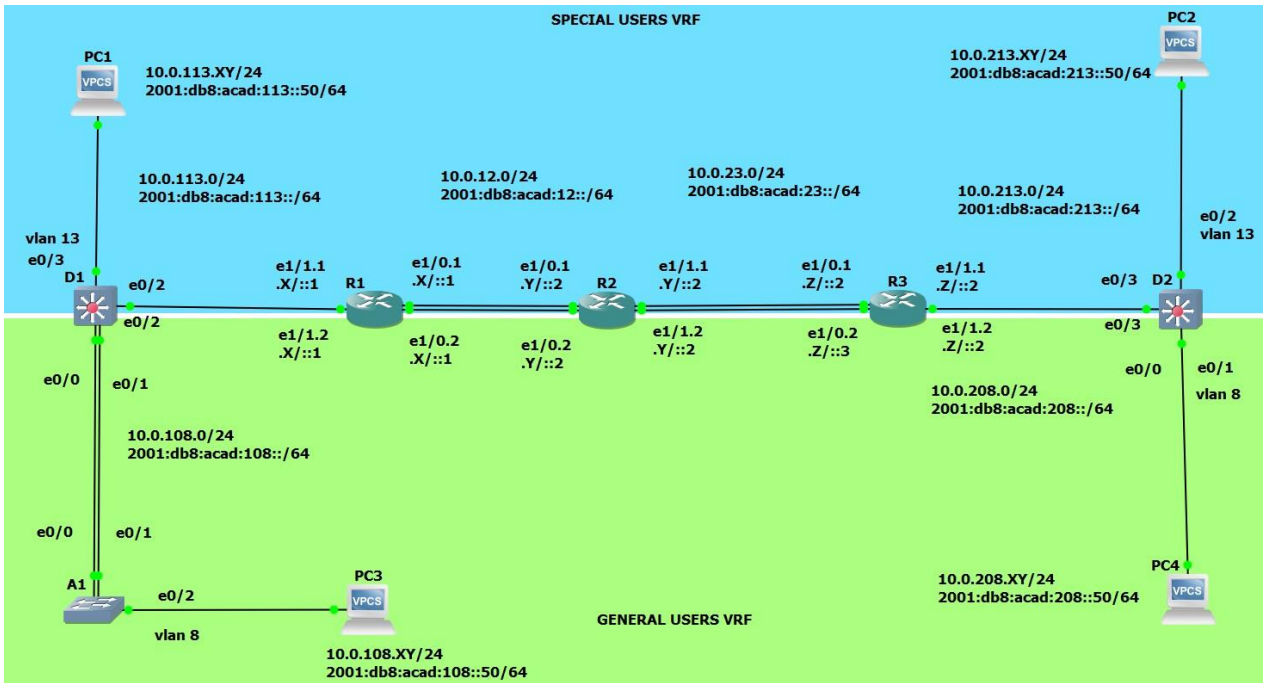
Device	Interface	IPv4 Address	IPv6 Address	IPv6 Link-Local
R1	E1/0.1	10.0.12.1/24	2001:db8:acad:12::1/64	fe80::1:1
	E1/0.2	10.0.12.1/24	2001:db8:acad:12::1/64	fe80::1:2
	E1/1.1	10.0.113.1/24	2001:db8:acad:113::1/64	fe80::1:3
	E1/1.2	10.0.108.1/24	2001:db8:acad:108::1/64	fe80::1:4
R2	E1/0.1	10.0.12.4/24	2001:db8:acad:12::2/64	fe80::2:1
	E1/0.2	10.0.12.4/24	2001:db8:acad:12::2/64	fe80::2:2
	E1/1.1	10.0.23.4/24	2001:db8:acad:23::2/64	fe80::2:3
	E1/1.2	10.0.23.4/24	2001:db8:acad:23::2/64	fe80::2:4
R3	E1/0.1	10.0.23.8/24	2001:db8:acad:23::3/64	fe80::3:1
	E1/0.2	10.0.23.8/24	2001:db8:acad:23::3/64	fe80::3:2
	E1/1.1	10.0.213.8/24	2001:db8:acad:213::1/64	fe80::3:3
	E1/1.2	10.0.208.8/24	2001:db8:acad:208::1/64	fe80::3:4
PC1	NIC	10.0.113.14/24	2001:db8:acad:113::50/64	EUI-64
PC2	NIC	10.0.213.14/24	2001:db8:acad:213::50/64	EUI-64
PC3	NIC	10.0.108.14/24	2001:db8:acad:108::50/64	EUI-64
PC4	NIC	10.0.208.14/24	2001:db8:acad:208::50/64	EUI-64

2 ESCENARIO REALIZADO GNS3

Figura 2. Simulación de escenario 1

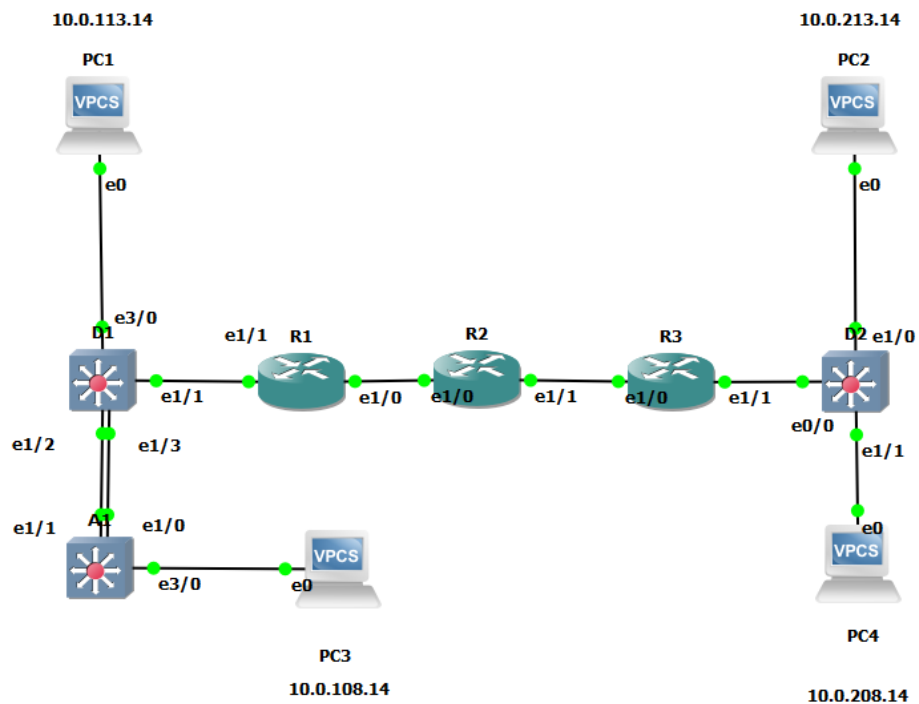

Johan Sneyder Santamaria Ariza_208014_37

Fuente: Autor

2.1 TOPOLOGIA ESCENARIO DISEÑO GNS3

Figura 3. Topología escenario diseño GNS3

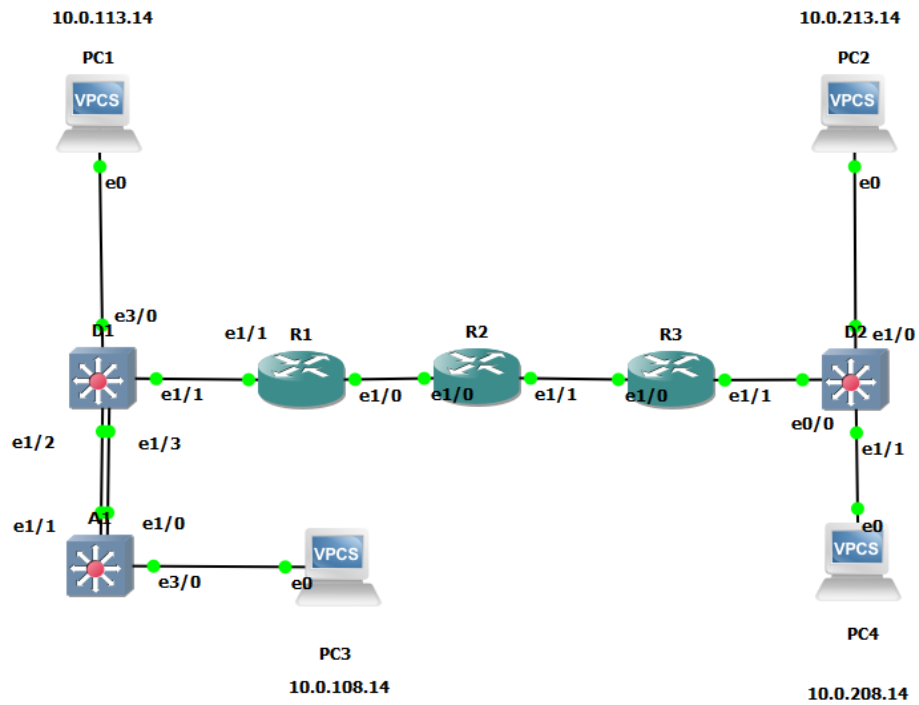

Johan Sneyder Santamaria Ariza_208014_37

Fuente: Autor

3. Configuración ajustes básicos para cada dispositivo

Router R1:

```
R1(config)#hostname R1
R1(config)#ipv6 unicast-routing no ip domain lookup
R1(config)#banner motd # R1, ENCOR Skills Assessment, Scenario 2 #
R1(config)#line con 0
R1(config)#exec-timeout 0 0
R1(config)#logging synchronous
R1(config)#exit
```

Router R2

```
R2(config)#hostname R2
R2(config)#ipv6 unicast-routing no ip domain lookup
R2(config)#banner motd # R2, ENCOR Skills Assessment, Scenario 2 #
R2(config)#line con 0
R2(config)#exec-timeout 0 0
R2(config)#logging synchronous
R2(config)#exit
```

Router R3

```
R3(config)#hostname R3
R3(config)#ipv6 unicast-routing no ip domain lookup
R3(config)#banner motd # R3, ENCOR Skills Assessment, Scenario 2 #
R3(config)#line con 0
R3(config)#exec-timeout 0 0
R3(config)#logging synchronous
R3(config)#exit
```

Switch D1:

```
D1(config)#hostname D1
D1(config)#ip routing
D1(config)#ipv6 unicast-routing
D1(config)#no ip domain lookup
D1(config)#banner motd # D1, ENCOR Skills Assessment, Scenario 2 #
D1(config)#line con 0
D1(config)#exec-timeout 0 0
D1(config)#logging synchronous
D1(config)#exit
D1(config)#vlan 8
D1(config)#name General-Users
D1(config)#exit
D1(config)#vlan 13
```

```
D1(config)#name Special-Users
D1(config)#exit
```

Switch D2:

```
D2(config)#hostname D2
D2(config)#ip routing
D2(config)#ipv6 unicast-routing
D2(config)#no ip domain lookup
D2(config)#banner motd # D2, ENCOR Skills Assessment, Scenario 2 #
D2(config)#line con 0
D2(config)#exec-timeout 0 0
D2(config)#logging synchronous
D2(config)#exit
D2(config)#vlan 8
D2(config)#name General-Users
D2(config)#exit
D2(config)#vlan 13
D2(config)#name Special-Users
D2(config)#exit
```

Switch D3:

```
D2(config)#hostname A1
D2(config)#ipv6 unicast-routing
D2(config)#no ip domain lookup
D2(config)#banner motd # A1, ENCOR Skills Assessment, Scenario 2 #
D2(config)#line con 0
D2(config)#exec-timeout 0 0
D2(config)#logging synchronous
D2(config)#exit
D2(config)#vlan 8
D2(config)#name General-Users
D2(config)#exit
```

3.1 Guardar las configuraciones en cada uno de los dispositivos

Router R1:

```
R1#erase nvram:
R1#copy runn start
```

Router R2:

```
R2#erase nvram:
R2#copy runn start
```

Router R3:

R3#erase nvram:
R3#copy runn start

Switch D1:
D1#erase nvram:
D1#copy runn start

Switch D2:
D2#erase nvram:
D2#copy runn start

Switch D3:
D3#erase nvram:
D3#copy runn start

3.2 Configure los PC1, PC2, PC3 y PC4 de acuerdo con la tabla de direccionamiento

PC1:

Figura 4. IP – PC1

The figure consists of two parts: a network diagram on the left and a terminal screenshot on the right.

Network Diagram: Shows a network topology with three switches (A1, D1, D2) and three routers (R1, R2, R3). PC1 (VPCS) is connected to switch A1 (E0/1) and has IP 10.0.113.14. PC3 (VPCS) is connected to switch D1 (E0/1) and has IP 10.0.108.14. The diagram also shows various interconnections between the switches and routers.

Terminal Screenshot: Shows the configuration of PC1 in a Solar-PuTTY window. The terminal output is as follows:

```
VPCS is free software, distributed under the terms of the "BSD" licence.  
Source code and license can be found at vpcs.sf.net.  
For more information, please visit wiki.freecode.com.cn.  
  
Press '?' to get help.  
  
Executing the startup file  
  
Checking for duplicate address...  
PC1 : 10.0.113.14 255.255.255.0 gateway 10.0.113.1  
PC1 : 2001:db8:acad:113::50/64  
PC1> show ip all  
NAME IP/MASK GATEWAY MAC DNS  
PC1 10.0.113.14/24 10.0.113.1 00:50:79:66:68:00  
PC1> show ip  
NAME : PC1[1]  
IP/MASK : 10.0.113.14/24  
GATEWAY : 10.0.113.1  
DNS :  
MAC : 00:50:79:66:68:00  
LPORT : 20032  
RHOST:PORT : 127.0.0.1:20033  
MTU : 1500  
  
PC1> save  
Saving startup configuration to startup.vpc  
. done  
PC1>
```

At the bottom of the terminal window, there is a footer: "solarwinds Solar-PuTTY free tool © 2019 SolarWinds Worldwide, LLC. All rights reserved."

Figura 5. IP – PC2

The network diagram shows three PCs (PC1, PC2, PC3) connected to two routers (R1, R2). PC1 (10.0.113.14) is connected to R1 (E0/1) and R2 (E0/3). PC2 (10.0.213.14) is connected to R1 (E0/0). PC3 (10.0.108.14) is connected to R2 (E0/0). R1 and R2 are connected to each other (E1/0).

```

VPCS is free software, distributed under the terms of the "BSD" licence.
Source code and license can be found at vpcs.sf.net.
For more information, please visit wiki.freecode.com.cn.

Press '?' to get help.

Executing the startup file

PC2> ip 10.0.213.14 255.255.255.0 gateway 10.0.213.1
Bad command: "10.0.213.14 255.255.255.0 gateway 10.0.213.1". Use ? for help.

PC2> ip 10.0.213.14 255.255.255.0 gateway 10.0.213.1
Checking for duplicate address...
PC2 : 10.0.213.14 255.255.255.0 gateway 10.0.213.1

PC2> ip 2001:db8:acad:113::50/64
PC1 : 2001:db8:acad:113::50/64

PC2> show ip

NAME          : PC2[1]
IP/MASK       : 10.0.213.14/24
GATEWAY      : 10.0.213.1
DNS           :
MAC           : 00:50:79:66:68:01
LPORT        : 20034
RHOST:PORT   : 127.0.0.1:20035
MTU           : 1500

PC2> save
Saving startup configuration to startup.vpc
. done

PC2>
    
```

Johan Sneyder Santamaria Ariza_208014_37

solarwinds | Solar-PuTTY free tool © 2019 SolarWinds Worldwide, LLC. All rights reserved.

Figura 6. IP – PC3

```

NAME          : PC3[1]
IP/MASK       : 10.0.108.14/24
GATEWAY      : 10.0.108.1
DNS           :
MAC           : 00:50:79:66:68:02
LPORT        : 20036
RHOST:PORT   : 127.0.0.1:20037
MTU           : 1500

PC3>
    
```

solarwinds | Solar-PuTTY free tool © 2019 SolarWinds Worldwide, LLC. All rights reserved.

Figura 7. IP – PC4

```
NAME      : PC4[1]
IP/MASK   : 10.0.208.14/24
GATEWAY   : 10.0.208.1
DNS       :
MAC       : 00:50:79:66:68:03
LPORT     : 20038
RHOST:PORT : 127.0.0.1:20039
MTU       : 1500

PC4> █
```

solarwinds | Solar-PuTTY *free tool* © 2019 SolarWinds Worldwide, LLC. All rights reserved.

4. Configure VRF y enrutamiento estático

4.1 En R1, R2 y R3, configure VRF-Lite VRF como se muestra en el diagrama de topología. Configure dos VRF, Usuarios generales, Usuarios especiales los VRF deben admitir IPv4 e IPv6.

Router R1:

```
R1#configure terminal
R1(config)#vrf definition Special-Users
R1(config-vrf)#address-family ipv4
R1(config-vrf-af)#address-family ipv6
R1(config-vrf-af)#exit
R1(config-vrf)#vrf definition General-Users
R1(config-vrf)#address-family ipv4
R1(config-vrf-af)#address-family ipv6
R1(config-vrf)#exit
```

Router R2:

```
R2#configure terminal
R2(config)#vrf definition Special-Users
R2(config-vrf)#address-family ipv4
R2(config-vrf-af)#address-family ipv6
R2(config-vrf-af)#exit
R2(config-vrf)#vrf definition General-Users
R2(config-vrf)#address-family ipv4
R2(config-vrf-af)#address-family ipv6
R2(config-vrf)#exit
```

Figura 9. Validación VRF Router2

The network diagram shows three routers (R1, R2, R3) connected in a line. R1 is connected to PC1 (10.0.113.14) and PC3 (10.0.108.14). R2 is connected to R1 and R3. R3 is connected to PC2 (10.0.213.14) and PC4 (10.0.208.14). The terminal screenshot shows the configuration of VRFs on R2:

```

R2#show ip vrf interface
Interface      IP-Address      VRF              Protocol
Et1/0/2        10.0.12.4       General-Users    up
Et1/1/2        10.0.23.4       General-Users    up
Et1/0/1        10.0.12.4       Special-Users    up
Et1/1/1        10.0.23.4       Special-Users    up
R2#
  
```

Figura 10. Validación VRF Router3

The network diagram shows three routers (R1, R2, R3) connected in a line. R1 is connected to PC1 (10.0.113.14) and PC3 (10.0.108.14). R2 is connected to R1 and R3. R3 is connected to PC2 (10.0.213.14) and PC4 (10.0.208.14). The terminal screenshot shows the configuration of VRFs on R3:

```

R3#show ip vrf interface
Interface      IP-Address      VRF              Protocol
Et1/0/2        10.0.23.8       General-Users    up
Et1/1/2        10.0.208.8       General-Users    up
Et1/0/1        10.0.23.8       Special-Users    up
Et1/1/1        10.0.213.8       Special-Users    up
R3#
  
```

4.2 En R1, R2 y R3, configure las interfaces IPv4 e IPv6 en cada VRF como se detalla en la tabla de direccionamiento anterior.

Router R1:

```
R1(config)#interface e1/0
R1(config)#no shutdown
R1(config)#interface e1/0.1
R1(config-if)#encapsulation dot1Q 13
R1(config-if)#vrf forwarding Special-Users
R1(config-if)#ip address 10.0.12.1 255.255.255.0
R1(config-if)#ipv6 address fe80::1:1 link-local
R1(config-if)#ipv6 address 2001:db8:acad:12::1/64
R1(config-if)#no shutdown
R1(config-if)#exit
```

```
R1(config)#interface e/0.2
R1(config-if)#encapsulation dot1Q 8
R1(config-if)#vrf forwarding General-Users
R1(config-if)#ip address 10.0.12.1 255.255.255.0
R1(config-if)#ipv6 address 2001:db8:acad:12::1/64
R1(config-if)#ipv6 address fe80::1:2 link-local
R1(config-if)#no shutdown
R1(config-if)#exit
```

```
R1(config)#interface e1/1
R1(config)#no shutdown
R1(config)#interface e1/1.1
R1(config-if)#encapsulation dot1Q 13
R1(config-if)#vrf forwarding Special-Users
R1(config-if)#ip address 10.0.113.1 255.255.255.0
R1(config-if)#ipv6 address 2001:db8:acad:113::1/64
R1(config-if)#ipv6 address fe80::1:3 link-local
R1(config-if)#no shutdown
R1(config-if)#exit
```

```
R1(config)#interface e1/1.2
R1(config-if)#encapsulation dot1Q 8
R1(config-if)#vrf forward General-Users
```

```
R1(config-if)#ip address 10.0.108.1 255.255.255.0
R1(config-if)#ipv6 address 2001:db8:acad:108::1/64
R1(config-if)#ipv6 address fe80::1:4 link-local
R1(config-if)#no shutdown
R1(config-if)#exit
```

Router R2:

```
R2(config)#interface e1/0
R2(config)#no shutdown
R2(config)#interface e1/0.1
R2(config-if)#encapsulation dot1Q 13
R2(config-if)#vrf forwarding Special-Users
R2(config-if)#ip address 10.0.12.4 255.255.255.0
R2(config-if)#ipv6 address fe80::1:1 link-local
R2(config-if)#ipv6 address 2001:db8:acad:12::4/64
R2(config-if)#no shutdown
R2(config-if)#exit
```

```
R2(config)#interface e/0.2
R2(config-if)#encapsulation dot1Q 8
R2(config-if)#vrf forwarding General-Users
R2(config-if)#ip address 10.0.12.4 255.255.255.0
R2(config-if)#ipv6 address 2001:db8:acad:12::4/64
R2(config-if)#ipv6 address fe80::1:2 link-local
R2(config-if)#no shutdown
R2(config-if)#exit
```

```
R2(config)#interface e1/1
R2(config)#no shutdown
R2(config)#interface e1/1.1
R2(config-if)#encapsulation dot1Q 13
R2(config-if)#vrf forwarding Special-Users
R2(config-if)#ip address 10.0.23.4 255.255.255.0
R2(config-if)#ipv6 address 2001:db8:acad:23::4/64
R2(config-if)#ipv6 address fe80::1:3 link-local
R2(config-if)#no shutdown
R2(config-if)#exit
```

```
R2(config)#interface e1/1.2
R2(config-if)#encapsulation dot1Q 8
R2(config-if)#vrf forward General-Users
R2(config-if)#ip address 10.0.23.4 255.255.255.0
R2(config-if)#ipv6 address 2001:db8:acad:23::4/64
```

```
R2(config-if)#ipv6 address fe80::1:4 link-local
R2(config-if)#no shutdown
R2(config-if)#exit
```

Router R3:

```
R3(config)#interface e1/0
R3(config)#no shutdown
R3(config)#interface e1/0.1
R3(config-if)#encapsulation dot1Q 13
R3(config-if)#vrf forwarding Special-Users
R3(config-if)#ip address 10.0.23.8 255.255.255.0
R3(config-if)#ipv6 address fe80::1:1 link-local
R3(config-if)#ipv6 address 2001:db8:acad:23::8/64
R3(config-if)#no shutdown
R3(config-if)#exit
```

```
R3(config)#interface e/0.2
R3(config-if)#encapsulation dot1Q 8
R3(config-if)#vrf forwarding General-Users
R3(config-if)#ip address 10.0.23.8 255.255.255.0
R3(config-if)#ipv6 address 2001:db8:acad:23::8/64
R3(config-if)#ipv6 address fe80::1:2 link-local
R3(config-if)#no shutdown
R3(config-if)#exit
```

```
R3(config)#interface e1/1
R3(config)#no shutdown
R3(config)#interface e1/1.1
R3(config-if)#encapsulation dot1Q 13
R3(config-if)#vrf forwarding Special-Users
R3(config-if)#ip address 10.0.213.8 255.255.255.0
R3(config-if)#ipv6 address 2001:db8:acad:213::8/64
R3(config-if)#ipv6 address fe80::1:3 link-local
R3(config-if)#no shutdown
R3(config-if)#exit
```

```
R3(config)#interface e1/1.2
R3(config-if)#encapsulation dot1Q 8
R3(config-if)#vrf forward General-Users
R3(config-if)#ip address 10.0.208.8 255.255.255.0
R3(config-if)#ipv6 address 2001:db8:acad:208::8/64
R3(config-if)#ipv6 address fe80::1:4 link-local
R3(config-if)#no shutdown
```

```
R3(config-if)#exit
```

4.3 En R1 y R3, configure la estática predeterminada rutas que apuntan a R2.
Configurar rutas estáticas VRF para IPv4 y IPv6 en ambos VRF

Router R1:

```
R1(config)#configure terminal
R1(config)#ip route vrf General-Users 0.0.0.0 0.0.0.0 10.0.12.4
R1(config)#ip route vrf Special-Users 0.0.0.0 0.0.0.0 10.0.12.4
R1(config)#ipv6 route vrf General-Users: ::/0 2001:db8:acad:12::4
R1(config)#ipv6 route vrf Special-Users: ::/0 2001:db8:acad:12::4 exit
R1(config)#exit
R1#erase nvram:
R1#copy runn start
```

Router R2:

```
R2#configure terminal
R2(config)#ip route vrf General-User 10.0.108.0 255.255.255.0 10.0.12.1
R2(config)#ip route vrf General-User 10.0.208.0 255.255.255.0 10.0.23.8
R2(config)#ip route vrf Special-User 10.0.113.0 255.255.255.0 10.0.12.1
R2(config)#ip route vrf Special-User 10.0.213.0 255.255.255.0 10.0.23.8
R2(config)#ipv6 route vrf General-User 2001:db8:acad:108::/64
2001:db8:acad:12::1
R2(config)#ipv6 route vrf General-User 2001:db8:acad:208::/64
2001:db8:acad:23::8
R2(config)#ipv6 route vrf Special-User 2001:db8:acad:113::/64
2001:db8:acad:12::1
R2(config)#ipv6 route vrf Special-User 2001:db8:acad:213::/64
2001:db8:acad:23::8
R2(config)#exit
R2#erase nvram:
R2#copy runn start
```

Router R3:

```
R3#configure terminal
R3(config)#ip route vrf General-User 0.0.0.0 0.0.0.0 10.0.23.4
R3(config)#ip route vrf Special-User 0.0.0.0 0.0.0.0 10.0.23.4
R3(config)#ipv6 route vrf General-User ::/0 2001:db8:acad:23::4
R3(config)#ipv6 route vrf Special-User ::/0 2001:db8:acad:23::4
R3(config)#exit
```

R3#erase nvram:
R3#copy runn start

4.4 Verifique la conectividad en cada VRF. Desde R1, verifique la conectividad a R3:

- ping vrf General-Users 10.0.208.8

Figura 11. Validación conectividad VRF

The figure shows a network diagram and a terminal screenshot. The diagram illustrates a multi-VRF environment with three routers (R1, R2, R3) and four PCs (PC1, PC2, PC3, PC4). R1 is connected to R2, which is connected to R3. PC1 (10.0.113.14) is connected to R1. PC2 (10.0.213.14) is connected to R3. PC3 (10.0.108.14) is connected to R1. PC4 (10.0.208.14) is connected to R3. The terminal screenshot shows the following commands and output on R1:

```
R1#ping vrf General-Users 10.0.208.8
Type escape sequence to abort.
Sending 5, 100-byte ICMP Echos to 10.0.208.8, timeout is 2 seconds:
!!!!
Success rate is 100 percent (5/5), round-trip min/avg/max = 32/39/44 ms
R1#ping vrf General-Users 2001:db8:acad:208::1
Type escape sequence to abort.
Sending 5, 100-byte ICMP Echos to 2001:008:ACAD:208::1, timeout is 2 seconds:
!!!!
Success rate is 100 percent (5/5), round-trip min/avg/max = 36/39/44 ms
R1#ping vrf Special-Users 10.0.213.8
Unable to find vrf "Special-Users10.0.213.8"
R1#ping vrf Special-Users 10.0.213.8
Type escape sequence to abort.
Sending 5, 100-byte ICMP Echos to 10.0.213.8, timeout is 2 seconds:
!!!!
Success rate is 100 percent (5/5), round-trip min/avg/max = 40/40/44 ms
R1#ping vrf Special-Users 2001:db8:acad:213::1
Type escape sequence to abort.
Sending 5, 100-byte ICMP Echos to 2001:008:ACAD:213::1, timeout is 2 seconds:
!!!!
Success rate is 100 percent (5/5), round-trip min/avg/max = 36/39/40 ms
R1#
```

- ping vrf General-Users 2001:db8:acad:208::1

Figura 12. Validación conectividad VRF

The figure shows a network diagram and a terminal screenshot, identical to Figure 11. The diagram illustrates a multi-VRF environment with three routers (R1, R2, R3) and four PCs (PC1, PC2, PC3, PC4). R1 is connected to R2, which is connected to R3. PC1 (10.0.113.14) is connected to R1. PC2 (10.0.213.14) is connected to R3. PC3 (10.0.108.14) is connected to R1. PC4 (10.0.208.14) is connected to R3. The terminal screenshot shows the following commands and output on R1:

```
R1#ping vrf General-Users 10.0.208.8
Type escape sequence to abort.
Sending 5, 100-byte ICMP Echos to 10.0.208.8, timeout is 2 seconds:
!!!!
Success rate is 100 percent (5/5), round-trip min/avg/max = 32/39/44 ms
R1#ping vrf General-Users 2001:db8:acad:208::1
Type escape sequence to abort.
Sending 5, 100-byte ICMP Echos to 2001:008:ACAD:208::1, timeout is 2 seconds:
!!!!
Success rate is 100 percent (5/5), round-trip min/avg/max = 36/39/44 ms
R1#ping vrf Special-Users 10.0.213.8
Unable to find vrf "Special-Users10.0.213.8"
R1#ping vrf Special-Users 10.0.213.8
Type escape sequence to abort.
Sending 5, 100-byte ICMP Echos to 10.0.213.8, timeout is 2 seconds:
!!!!
Success rate is 100 percent (5/5), round-trip min/avg/max = 40/40/44 ms
R1#ping vrf Special-Users 2001:db8:acad:213::1
Type escape sequence to abort.
Sending 5, 100-byte ICMP Echos to 2001:008:ACAD:213::1, timeout is 2 seconds:
!!!!
Success rate is 100 percent (5/5), round-trip min/avg/max = 36/39/40 ms
R1#
```

5. Configurar Capa 2

5.1 En D1 y D2, apague G1/0/1 a G1/0/24, en A1 apague F0/1 – F0/24, G0/1 -G0/2.

Figura 15. Apagado Interfaz D1

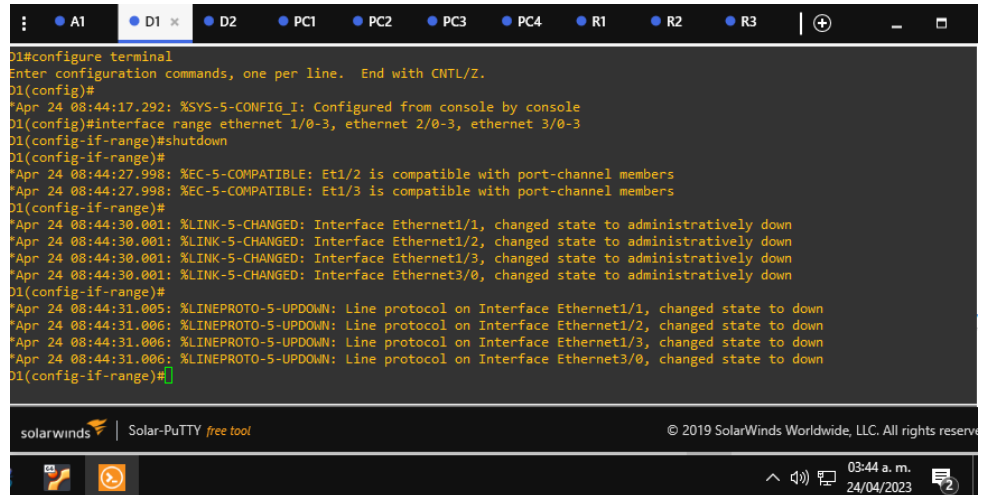

```
D1#configure terminal
Enter configuration commands, one per line. End with CNTL/Z.
D1(config)#
*Apr 24 08:44:17.292: %SYS-5-CONFIG_I: Configured from console by console
D1(config)#interface range ethernet 1/0-3, ethernet 2/0-3, ethernet 3/0-3
D1(config-if-range)#shutdown
D1(config-if-range)#
*Apr 24 08:44:27.998: %EC-5-COMPATIBLE: Et1/2 is compatible with port-channel members
*Apr 24 08:44:27.998: %EC-5-COMPATIBLE: Et1/3 is compatible with port-channel members
D1(config-if-range)#
*Apr 24 08:44:30.001: %LINK-5-CHANGED: Interface Ethernet1/1, changed state to administratively down
*Apr 24 08:44:30.001: %LINK-5-CHANGED: Interface Ethernet1/2, changed state to administratively down
*Apr 24 08:44:30.001: %LINK-5-CHANGED: Interface Ethernet1/3, changed state to administratively down
*Apr 24 08:44:30.001: %LINK-5-CHANGED: Interface Ethernet3/0, changed state to administratively down
D1(config-if-range)#
*Apr 24 08:44:31.005: %LINEPROTO-5-UPDOWN: Line protocol on Interface Ethernet1/1, changed state to down
*Apr 24 08:44:31.006: %LINEPROTO-5-UPDOWN: Line protocol on Interface Ethernet1/2, changed state to down
*Apr 24 08:44:31.006: %LINEPROTO-5-UPDOWN: Line protocol on Interface Ethernet1/3, changed state to down
*Apr 24 08:44:31.006: %LINEPROTO-5-UPDOWN: Line protocol on Interface Ethernet3/0, changed state to down
D1(config-if-range)#
```

D1#configure terminal

D1(config)#interface range ethernet 1/0-3, ethernet 2/0-3, ethernet 3/0-3

D1(config-if-range)#shutdown

D1(config-if-range)#

Figura 16. Apagado Interfaz D2

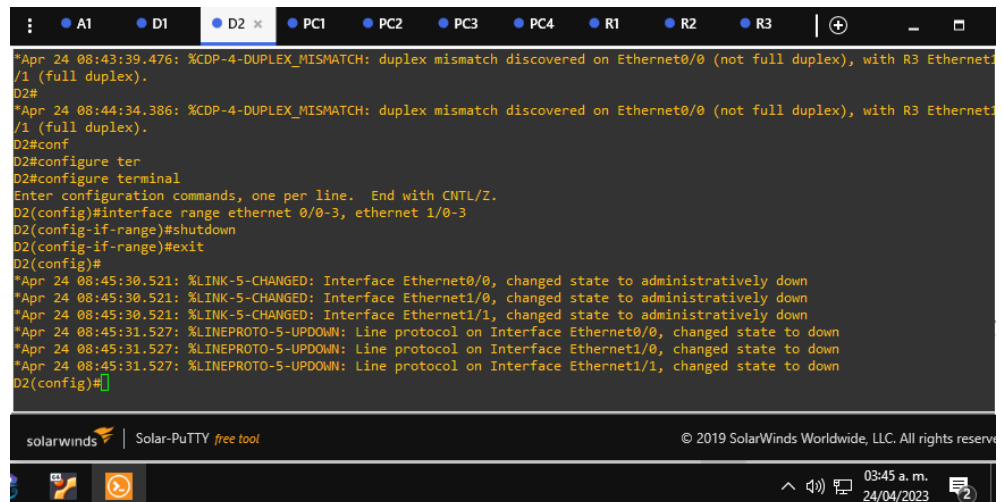

```
*Apr 24 08:43:39.476: %CDP-4-DUPLEX_MISMATCH: duplex mismatch discovered on Ethernet0/0 (not full duplex), with R3 Ethernet1/1 (full duplex).
D2#
*Apr 24 08:44:34.386: %CDP-4-DUPLEX_MISMATCH: duplex mismatch discovered on Ethernet0/0 (not full duplex), with R3 Ethernet1/1 (full duplex).
D2#conf
D2#configure ter
D2#configure terminal
Enter configuration commands, one per line. End with CNTL/Z.
D2(config)#interface range ethernet 0/0-3, ethernet 1/0-3
D2(config-if-range)#shutdown
D2(config-if-range)#exit
D2(config)#
*Apr 24 08:45:30.521: %LINK-5-CHANGED: Interface Ethernet0/0, changed state to administratively down
*Apr 24 08:45:30.521: %LINK-5-CHANGED: Interface Ethernet1/0, changed state to administratively down
*Apr 24 08:45:30.521: %LINK-5-CHANGED: Interface Ethernet1/1, changed state to administratively down
*Apr 24 08:45:31.527: %LINEPROTO-5-UPDOWN: Line protocol on Interface Ethernet0/0, changed state to down
*Apr 24 08:45:31.527: %LINEPROTO-5-UPDOWN: Line protocol on Interface Ethernet1/0, changed state to down
*Apr 24 08:45:31.527: %LINEPROTO-5-UPDOWN: Line protocol on Interface Ethernet1/1, changed state to down
D2(config)#
```

```
D2(config)#interface range ethernet 0/0-3, ethernet 1/0-3
```

```
D2(config-if-range)#shutdown
```

```
D2(config-if-range)#
```

```
D2(config-if-range)#exit
```

Figura 17. Apagado Interfaz A1

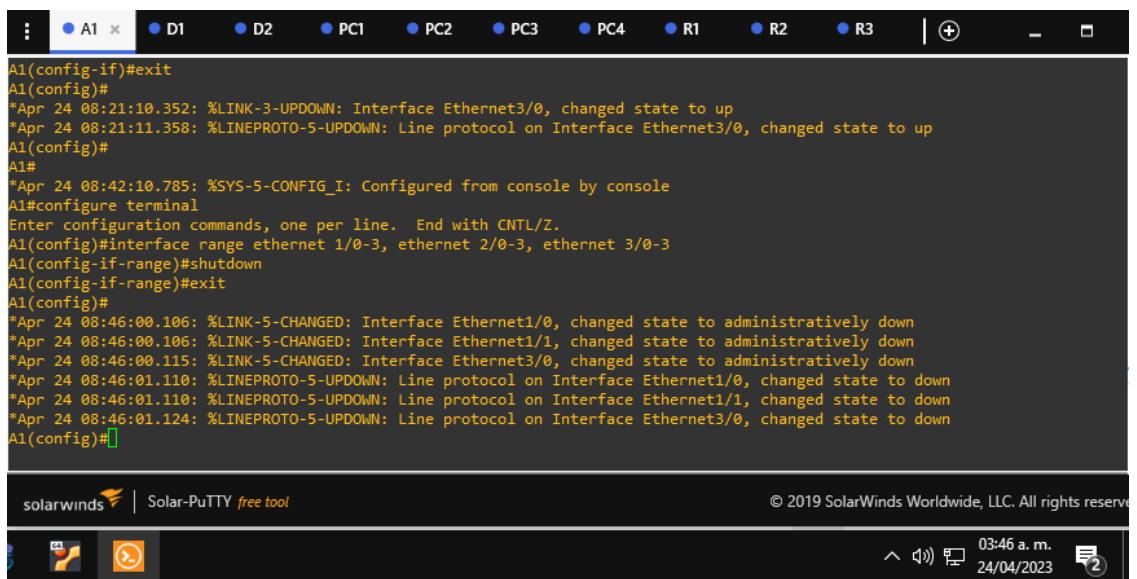

```
A1(config-if)#exit
A1(config)#
*Apr 24 08:21:10.352: %LINK-3-UPDOWN: Interface Ethernet3/0, changed state to up
*Apr 24 08:21:11.358: %LINEPROTO-5-UPDOWN: Line protocol on Interface Ethernet3/0, changed state to up
A1(config)#
A1#
*Apr 24 08:42:10.785: %SYS-5-CONFIG_I: Configured from console by console
A1#configure terminal
Enter configuration commands, one per line. End with CNTL/Z.
A1(config)#interface range ethernet 1/0-3, ethernet 2/0-3, ethernet 3/0-3
A1(config-if-range)#shutdown
A1(config-if-range)#exit
A1(config)#
*Apr 24 08:46:00.106: %LINK-5-CHANGED: Interface Ethernet1/0, changed state to administratively down
*Apr 24 08:46:00.106: %LINK-5-CHANGED: Interface Ethernet1/1, changed state to administratively down
*Apr 24 08:46:00.115: %LINK-5-CHANGED: Interface Ethernet3/0, changed state to administratively down
*Apr 24 08:46:01.110: %LINEPROTO-5-UPDOWN: Line protocol on Interface Ethernet1/0, changed state to down
*Apr 24 08:46:01.110: %LINEPROTO-5-UPDOWN: Line protocol on Interface Ethernet1/1, changed state to down
*Apr 24 08:46:01.124: %LINEPROTO-5-UPDOWN: Line protocol on Interface Ethernet3/0, changed state to down
A1(config)#
```

```
A1#configure terminal
```

```
A1(config)#interface range ethernet 1/0-3, ethernet 2/0-3, ethernet 3/0-3
```

```
A1(config-if-range)#shutdown
```

```
A1(config-if-range)#exit
```

5.2. En D1 y D2 configurar y habilitar el enlace G1/0/11 como troncal enlace

Figura 18. Configuración troncal enlace D1

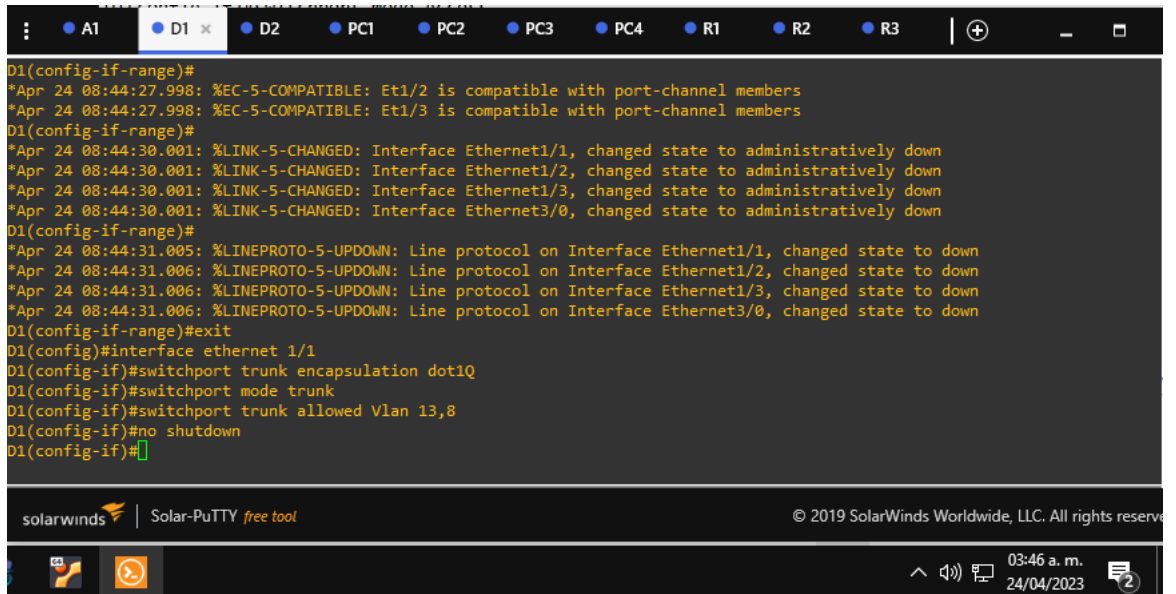

The screenshot shows a SolarWinds Solar-PuTTY terminal window with a tab for 'D1'. The terminal output displays the configuration of interface Ethernet1/1 on switch D1. It shows that the interface was previously administratively down and then brought up. The configuration steps include setting the mode to trunk, encapsulation to dot1Q, and allowing VLANs 13 and 8. The terminal text is as follows:

```
D1(config-if-range)#
*Apr 24 08:44:27.998: %EC-5-COMPATIBLE: Et1/2 is compatible with port-channel members
*Apr 24 08:44:27.998: %EC-5-COMPATIBLE: Et1/3 is compatible with port-channel members
D1(config-if-range)#
*Apr 24 08:44:30.001: %LINK-5-CHANGED: Interface Ethernet1/1, changed state to administratively down
*Apr 24 08:44:30.001: %LINK-5-CHANGED: Interface Ethernet1/2, changed state to administratively down
*Apr 24 08:44:30.001: %LINK-5-CHANGED: Interface Ethernet1/3, changed state to administratively down
*Apr 24 08:44:30.001: %LINK-5-CHANGED: Interface Ethernet3/0, changed state to administratively down
D1(config-if-range)#
*Apr 24 08:44:31.005: %LINEPROTO-5-UPDOWN: Line protocol on Interface Ethernet1/1, changed state to down
*Apr 24 08:44:31.006: %LINEPROTO-5-UPDOWN: Line protocol on Interface Ethernet1/2, changed state to down
*Apr 24 08:44:31.006: %LINEPROTO-5-UPDOWN: Line protocol on Interface Ethernet1/3, changed state to down
*Apr 24 08:44:31.006: %LINEPROTO-5-UPDOWN: Line protocol on Interface Ethernet3/0, changed state to down
D1(config-if-range)#exit
D1(config)#interface ethernet 1/1
D1(config-if)#switchport trunk encapsulation dot1Q
D1(config-if)#switchport mode trunk
D1(config-if)#switchport trunk allowed Vlan 13,8
D1(config-if)#no shutdown
D1(config-if)#
```

D1(config-if-range)#exit

D1(config)#interface ethernet 1/1

D1(config-if)#switchport trunk encapsulation dot1Q

D1(config-if)#switchport mode trunk

D1(config-if)#switchport trunk allowed Vlan 13,8

D1(config-if)#no shutdown

D1(config-if)#

Figura 19. Configuración troncal enlace D2

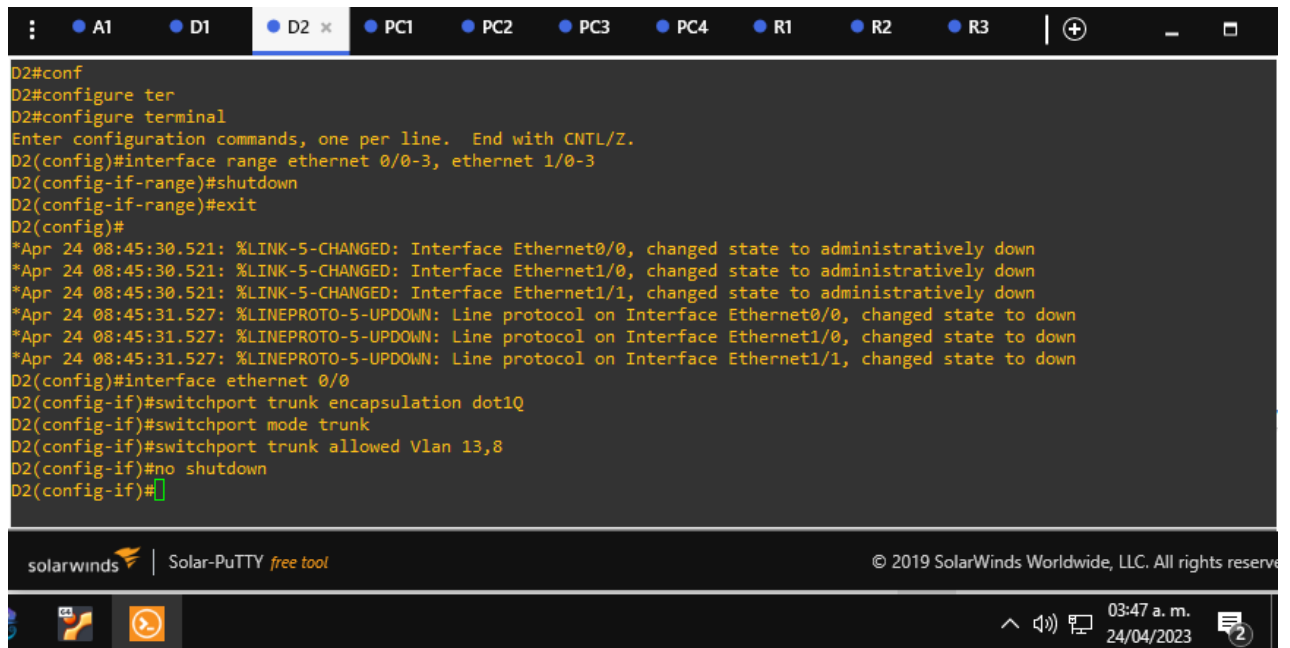

```
D2#conf
D2#configure ter
D2#configure terminal
Enter configuration commands, one per line. End with CNTL/Z.
D2(config)#interface range ethernet 0/0-3, ethernet 1/0-3
D2(config-if-range)#shutdown
D2(config-if-range)#exit
D2(config)#
*Apr 24 08:45:30.521: %LINK-5-CHANGED: Interface Ethernet0/0, changed state to administratively down
*Apr 24 08:45:30.521: %LINK-5-CHANGED: Interface Ethernet1/0, changed state to administratively down
*Apr 24 08:45:30.521: %LINK-5-CHANGED: Interface Ethernet1/1, changed state to administratively down
*Apr 24 08:45:31.527: %LINEPROTO-5-UPDOWN: Line protocol on Interface Ethernet0/0, changed state to down
*Apr 24 08:45:31.527: %LINEPROTO-5-UPDOWN: Line protocol on Interface Ethernet1/0, changed state to down
*Apr 24 08:45:31.527: %LINEPROTO-5-UPDOWN: Line protocol on Interface Ethernet1/1, changed state to down
D2(config)#interface ethernet 0/0
D2(config-if)#switchport trunk encapsulation dot1Q
D2(config-if)#switchport mode trunk
D2(config-if)#switchport trunk allowed Vlan 13,8
D2(config-if)#no shutdown
D2(config-if)#
```

D2(config)#interface ethernet 0/0

D2(config-if)#switchport trunk encapsulation dot1Q

D2(config-if)#switchport mode trunk

D2(config-if)#switchport trunk allowed Vlan 13,8

D2(config-if)#no shutdown

D2(config-if)#

5.3. En D1, configure y habilite, Interfaz G1/0/5 y G1/0/6, Canal de puerto 1 usando PAgP

En A1, configure y habilite, Interfaz F0/1 and F0/2, Canal de puerto 1 usando PAgP

Figura 20. Configuración puerto PAgP D1



```
}
*Apr 24 08:48:15.788: %EC-5-CANNOT_BUNDLE2: Et1/3 is not compatible with Et1/1 and will be suspended (vlan mask is different)
}
D1(config)#Interface e3/0
D1(config-if)#switchport mode Access
D1(config-if)#switchport access vlan 13
D1(config-if)#spanning-tree portfast
D1(config-if)#no shutdown
D1(config-if)#
*Apr 24 08:48:37.992: %LINK-3-UPDOWN: Interface Ethernet3/0, changed state to up
*Apr 24 08:48:38.998: %LINEPROTO-5-UPDOWN: Line protocol on Interface Ethernet3/0, changed state to up
D1(config-if)#
*Apr 24 08:48:48.344: %CDP-4-DUPLEX_MISMATCH: duplex mismatch discovered on Ethernet1/1 (not full duplex), with R1 Ethernet
/1 (full duplex).
D1(config-if)#
*Apr 24 08:49:38.202: %CDP-4-DUPLEX_MISMATCH: duplex mismatch discovered on Ethernet1/1 (not full duplex), with R1 Ethernet
/1 (full duplex).
D1(config-if)#
*Apr 24 08:49:41.663: %LINEPROTO-5-UPDOWN: Line protocol on Interface Ethernet1/3, changed state to up
*Apr 24 08:49:41.663: %LINEPROTO-5-UPDOWN: Line protocol on Interface Ethernet1/2, changed state to up
D1(config-if)#exit
D1(config)#inter range e1/2,e1/3
D1(config-if-range)#switchport trunk encapsulation dot1Q
D1(config-if-range)#switchport mode trunk
D1(config-if-range)#
*Apr 24 08:50:35.182: %CDP-4-DUPLEX_MISMATCH: duplex mismatch discovered on Ethernet1/1 (not full duplex), with R1 Ethernet
/1 (full duplex).
D1(config-if-range)#exit
```

D1(config-if)#exit

D1(config)#inter range e1/2,e1/3

D1(config-if-range)#switchport trunk encapsulation dot1Q

D1(config-if-range)#switchport mode trunk

D1(config-if-range)#channel-group 1 mode desirable

D1(config-if-range)#no shutdown

D1(config-if-range)#

D1(config-if-range)#exit

Figura 21. Configuración puerto PAgP A2

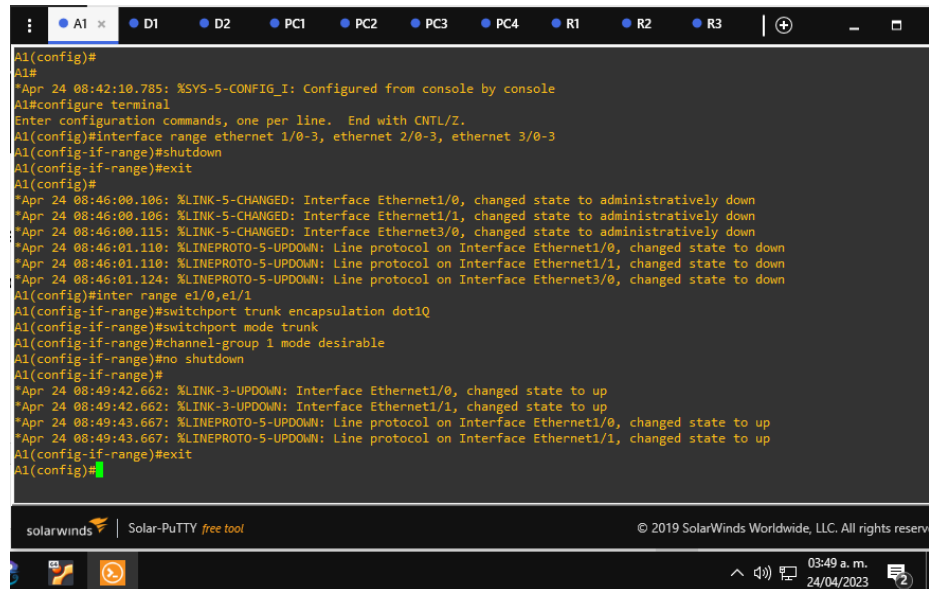

```
A1(config)#
A1#
*Apr 24 08:42:10.785: %SYS-5-CONFIG_I: Configured from console by console
A1#configure terminal
Enter configuration commands, one per line. End with CNTL/Z.
A1(config)#interface range ethernet 1/0-3, ethernet 2/0-3, ethernet 3/0-3
A1(config-if-range)#shutdown
A1(config-if-range)#exit
A1(config)#
*Apr 24 08:46:00.106: %LINK-5-CHANGED: Interface Ethernet1/0, changed state to administratively down
*Apr 24 08:46:00.106: %LINK-5-CHANGED: Interface Ethernet1/1, changed state to administratively down
*Apr 24 08:46:00.115: %LINK-5-CHANGED: Interface Ethernet3/0, changed state to administratively down
*Apr 24 08:46:01.110: %LINEPROTO-5-UPDOWN: Line protocol on Interface Ethernet1/0, changed state to down
*Apr 24 08:46:01.110: %LINEPROTO-5-UPDOWN: Line protocol on Interface Ethernet1/1, changed state to down
*Apr 24 08:46:01.124: %LINEPROTO-5-UPDOWN: Line protocol on Interface Ethernet3/0, changed state to down
A1(config)#inter range e1/0,e1/1
A1(config-if-range)#switchport trunk encapsulation dot1Q
A1(config-if-range)#switchport mode trunk
A1(config-if-range)#channel-group 1 mode desirable
A1(config-if-range)#no shutdown
A1(config-if-range)#
*Apr 24 08:49:42.662: %LINK-3-UPDOWN: Interface Ethernet1/0, changed state to up
*Apr 24 08:49:42.662: %LINK-3-UPDOWN: Interface Ethernet1/1, changed state to up
*Apr 24 08:49:43.667: %LINEPROTO-5-UPDOWN: Line protocol on Interface Ethernet1/0, changed state to up
*Apr 24 08:49:43.667: %LINEPROTO-5-UPDOWN: Line protocol on Interface Ethernet1/1, changed state to up
A1(config-if-range)#exit
A1(config)#
```

A1(config)#inter range e1/0,e1/1

A1(config-if-range)#switchport trunk encapsulation dot1Q

A1(config-if-range)#switchport mode trunk

A1(config-if-range)#channel-group 1 mode desirable

A1(config-if-range)#no shutdown

A1(config-if-range)#exit

5.4. Configure y habilite los puertos de acceso de la siguiente manera:

- En D1, configure la interfaz G1/0/23 como acceda al puerto en la VLAN 13 y habilite Portfast.
- En D2, configure la interfaz G1/0/23 como acceda al puerto en la VLAN 13 y habilite Portfast.
- En D2, configure la interfaz G1/0/24 como acceda al puerto en VLAN 8 y habilite Portfast.
- En A1, configurar la interfaz F0/23 como acceso puerto en VLAN 8 y habilite Portfast.

Figura 22. Configuración puertos accesos D1

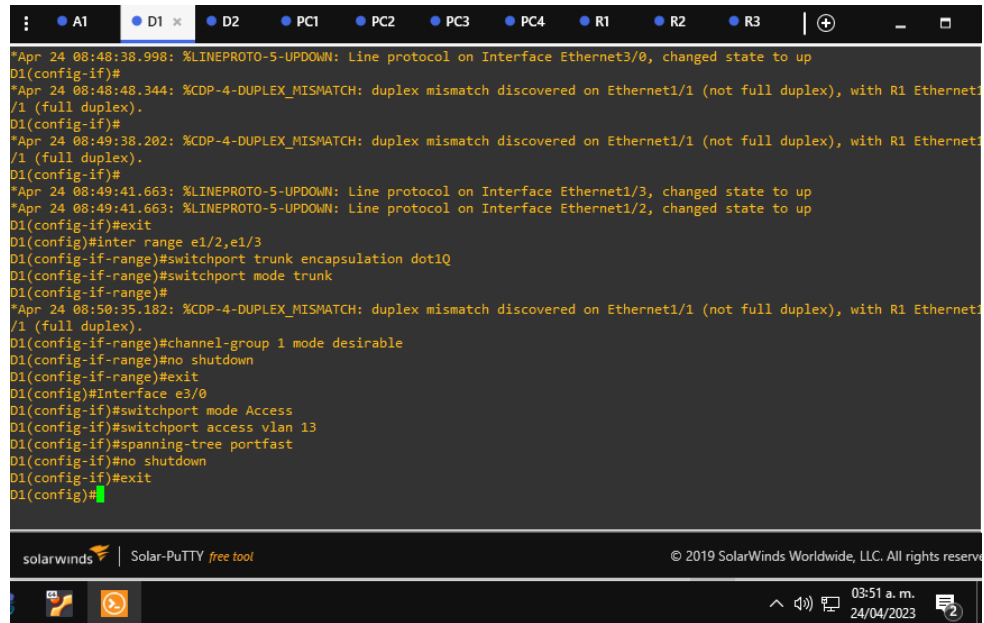

```
*Apr 24 08:48:38.998: %LINEPROTO-5-UPDOWN: Line protocol on Interface Ethernet3/0, changed state to up
D1(config-if)#
*Apr 24 08:48:48.344: %CDP-4-DUPLEX_MISMATCH: duplex mismatch discovered on Ethernet1/1 (not full duplex), with R1 Ethernet
/1 (full duplex).
D1(config-if)#
*Apr 24 08:49:38.202: %CDP-4-DUPLEX_MISMATCH: duplex mismatch discovered on Ethernet1/1 (not full duplex), with R1 Ethernet
/1 (full duplex).
D1(config-if)#
*Apr 24 08:49:41.663: %LINEPROTO-5-UPDOWN: Line protocol on Interface Ethernet1/3, changed state to up
*Apr 24 08:49:41.663: %LINEPROTO-5-UPDOWN: Line protocol on Interface Ethernet1/2, changed state to up
D1(config-if)#exit
D1(config)#inter range e1/2,e1/3
D1(config-if-range)#switchport trunk encapsulation dot1q
D1(config-if-range)#switchport mode trunk
D1(config-if-range)#
*Apr 24 08:50:35.182: %CDP-4-DUPLEX_MISMATCH: duplex mismatch discovered on Ethernet1/1 (not full duplex), with R1 Ethernet
/1 (full duplex).
D1(config-if-range)#channel-group 1 mode desirable
D1(config-if-range)#no shutdown
D1(config-if-range)#exit
D1(config)#Interface e3/0
D1(config-if)#switchport mode Access
D1(config-if)#switchport access vlan 13
D1(config-if)#spanning-tree portfast
D1(config-if)#no shutdown
D1(config-if)#exit
D1(config)#
```

```
D1(config)#Interface e3/0
D1(config-if)#switchport mode Access
D1(config-if)#switchport access vlan 13
D1(config-if)#spanning-tree portfast
D1(config-if)#no shutdown
D1(config-if)#exit
D1(config)#
```

Figura 23. Configuración puertos accesos D2

```
D2(config-if)#Interface e1/0
D2(config-if)#switchport mode Access
D2(config-if)#switchport access vlan 13
D2(config-if)#spanning-tree portfast
D2(config-if)#no shutdown
D2(config-if)#
*Apr 24 08:53:14.020: %LINK-3-UPDOWN: Interface Ethernet1/0, changed state to up
*Apr 24 08:53:15.025: %LINEPROTO-5-UPDOWN: Line protocol on Interface Ethernet1/0, changed state to up
D2(config-if)#exit
D2(config)#inter e1/1
D2(config-if)#switchport mode Access
D2(config-if)#switchport access vlan 8
D2(config-if)#spanning-tree portfast
D2(config-if)#no shutdown
D2(config-if)#exit
D2(config)#
*Apr 24 08:53:37.689: %CDP-4-DUPLEX_MISMATCH: duplex mismatch discovered on Ethernet0/0 (not full duplex), with R3 Ethernet1/1 (full duplex).
D2(config)#
*Apr 24 08:53:38.274: %LINK-3-UPDOWN: Interface Ethernet1/1, changed state to up
*Apr 24 08:53:39.279: %LINEPROTO-5-UPDOWN: Line protocol on Interface Ethernet1/1, changed state to up
D2(config)#
```

```
D2(config-if)#Interface e1/0
D2(config-if)#switchport mode Access
D2(config-if)#switchport access vlan 13
D2(config-if)#spanning-tree portfast
D2(config-if)#no shutdown
D2(config-if)#exit
D2(config)#
D2(config)#inter e1/1
D2(config-if)#switchport mode Access
D2(config-if)#switchport access vlan 8
D2(config-if)#spanning-tree portfast
D2(config-if)#no shutdown
D2(config-if)#exit
```

Figura 24. Configuración puertos accesos A1

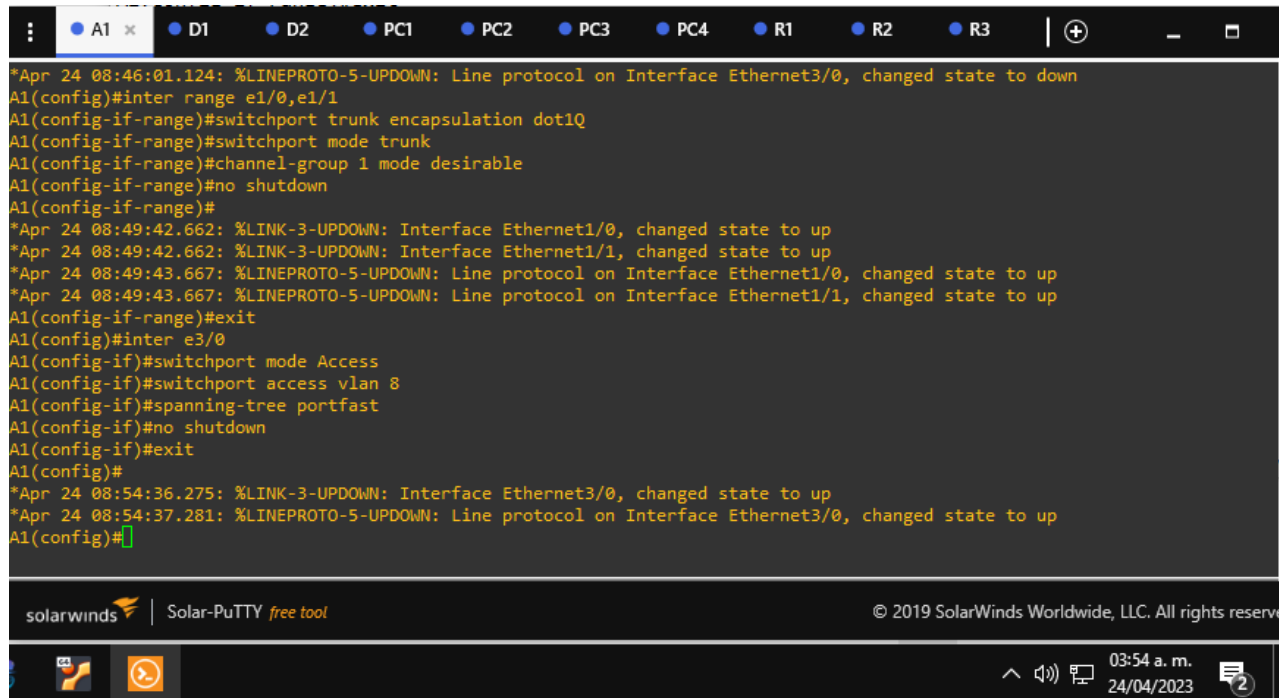

```
*Apr 24 08:46:01.124: %LINEPROTO-5-UPDOWN: Line protocol on Interface Ethernet3/0, changed state to down
A1(config)#inter range e1/0,e1/1
A1(config-if-range)#switchport trunk encapsulation dot1q
A1(config-if-range)#switchport mode trunk
A1(config-if-range)#channel-group 1 mode desirable
A1(config-if-range)#no shutdown
A1(config-if-range)#
*Apr 24 08:49:42.662: %LINK-3-UPDOWN: Interface Ethernet1/0, changed state to up
*Apr 24 08:49:42.662: %LINK-3-UPDOWN: Interface Ethernet1/1, changed state to up
*Apr 24 08:49:43.667: %LINEPROTO-5-UPDOWN: Line protocol on Interface Ethernet1/0, changed state to up
*Apr 24 08:49:43.667: %LINEPROTO-5-UPDOWN: Line protocol on Interface Ethernet1/1, changed state to up
A1(config-if-range)#exit
A1(config)#inter e3/0
A1(config-if)#switchport mode Access
A1(config-if)#switchport access vlan 8
A1(config-if)#spanning-tree portfast
A1(config-if)#no shutdown
A1(config-if)#exit
A1(config)#
*Apr 24 08:54:36.275: %LINK-3-UPDOWN: Interface Ethernet3/0, changed state to up
*Apr 24 08:54:37.281: %LINEPROTO-5-UPDOWN: Line protocol on Interface Ethernet3/0, changed state to up
A1(config)#
```

```
A1(config)#inter e3/0
```

```
A1(config-if)#switchport mode Access
```

```
A1(config-if)#switchport access vlan 8
```

```
A1(config-if)#spanning-tree portfast
```

```
A1(config-if)#no shutdown
```

```
A1(config-if)#exit
```

- 5.5. Desde PC1, verifique la conectividad IPv4 e IPv6 para PC2. Desde PC3, verifique la conectividad IPv4 e IPv6 para PC4.

PC1 a PC2:

10.0.213.14

2001:db8:acad:213::50/64

Figura 25. Ping PC1 A PC2



```
10.0.213.14 icmp_seq=2 timeout
10.0.213.14 icmp_seq=3 timeout
10.0.213.14 icmp_seq=4 timeout
10.0.213.14 icmp_seq=5 timeout

PC1> ping 10.0.213.14

10.0.213.14 icmp_seq=1 timeout
10.0.213.14 icmp_seq=2 timeout
10.0.213.14 icmp_seq=3 timeout
10.0.213.14 icmp_seq=4 timeout
10.0.213.14 icmp_seq=5 timeout

PC1> ping 2001:db8:acad:213::50/64

2001:db8:acad:213::50 icmp6_seq=1 ttl=58 time=106.991 ms
2001:db8:acad:213::50 icmp6_seq=2 ttl=58 time=54.102 ms
2001:db8:acad:213::50 icmp6_seq=3 ttl=58 time=52.980 ms
2001:db8:acad:213::50 icmp6_seq=4 ttl=58 time=58.509 ms
2001:db8:acad:213::50 icmp6_seq=5 ttl=58 time=60.031 ms

PC1> █
```

PC3 a PC4:

10.0.208.14

2001:db8:acad:208::50/64

Figura 26. Ping PC3 A PC4

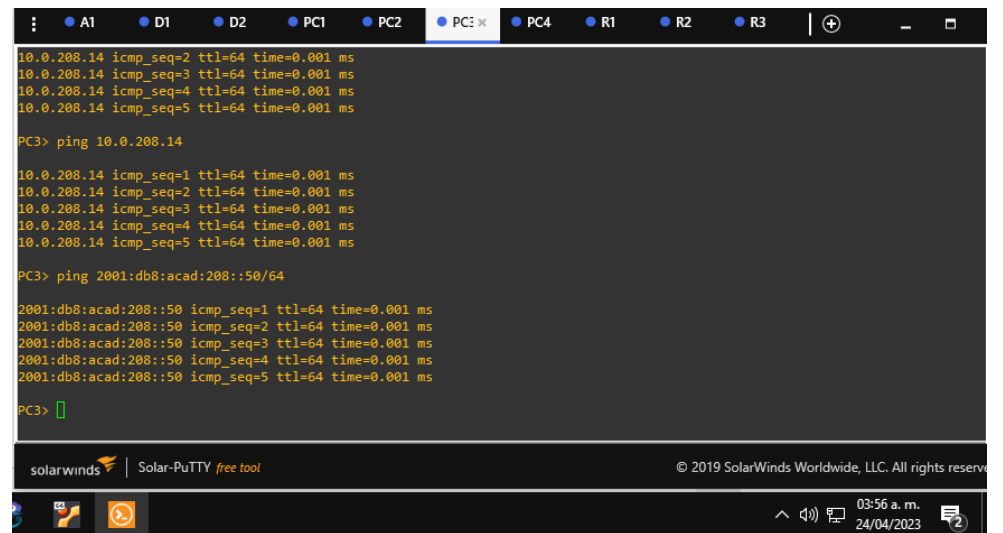

```
10.0.208.14 icmp_seq=2 ttl=64 time=0.001 ms
10.0.208.14 icmp_seq=3 ttl=64 time=0.001 ms
10.0.208.14 icmp_seq=4 ttl=64 time=0.001 ms
10.0.208.14 icmp_seq=5 ttl=64 time=0.001 ms

PC3> ping 10.0.208.14

10.0.208.14 icmp_seq=1 ttl=64 time=0.001 ms
10.0.208.14 icmp_seq=2 ttl=64 time=0.001 ms
10.0.208.14 icmp_seq=3 ttl=64 time=0.001 ms
10.0.208.14 icmp_seq=4 ttl=64 time=0.001 ms
10.0.208.14 icmp_seq=5 ttl=64 time=0.001 ms

PC3> ping 2001:db8:acad:208::50/64

2001:db8:acad:208::50 icmp_seq=1 ttl=64 time=0.001 ms
2001:db8:acad:208::50 icmp_seq=2 ttl=64 time=0.001 ms
2001:db8:acad:208::50 icmp_seq=3 ttl=64 time=0.001 ms
2001:db8:acad:208::50 icmp_seq=4 ttl=64 time=0.001 ms
2001:db8:acad:208::50 icmp_seq=5 ttl=64 time=0.001 ms

PC3> █
```

6. Configuración seguridad

6.1 Configure an enable secret as follows:

- Algorithm type: SCRYPT
- Password: nombrestudianteXYZ.

En R1, R2, R3, D1, D2 y A1

```
#config terminal
#service password-encryption
#enable secret johan148
#exit
```

6.2. Configure a local user:

- Name: admin
- Privilege level: 15
- Algorithm type: SCRYPT
- Password: nombrestudianteXYZ.

En R1, R2, R3, D1, D2 y A1

```
#configure terminal
#username admin secret 0 johan148
#username admin privilege 15 secret johan148
#exit
```

6.3. Enable AAA authentication using the local database on all lines.

En R1, R2, R3, D1, D2 y A1

```
#configure terminal
#aaa new-model
#aaa authentication login default local
#exit
```

Realizamos la validación de la seguridad implementada con el comando

sho run | include aaa|username

Figura 27. Validación seguridad R1

```
R1#sho run | include aaa|username
*Apr 27 02:59:53.763: %SYS-5-CONFIG_I: Configured from console by admin on consoleaaa new-model
aaa authentication login default local
aaa session-id common
username admin privilege 15 secret 5 $1$nN40$GVjyJtDLTkhsuW2.88L1q0
R1#
```



Figura 28. Validación seguridad R2

```
R2#sho run | include aaa|username
aaa new-model
aaa authentication login default local
aaa session-id common
username admin privilege 15 secret 5 $1$h2UE$hCcxncIpac7mSik5UMHRz/
R2#
```



Figura 29. Validación seguridad R3

```
R3#sho run | include aaa|username
aaa new-model
aaa authentication login default local
aaa session-id common
username admin privilege 15 secret 5 $1$oVh8$0gjaEkNbDQN4y4h17ozDy0
R3#
*Apr 27 02:53:01.799: %CDP-4-DUPLEX_MISMATCH: duplex mismatch discovered on Ethernet1/1 (not half duplex), with D2 Ethernet0
```

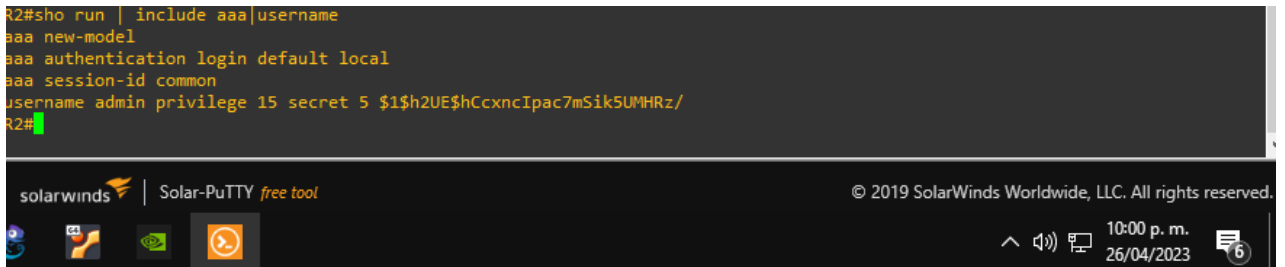

Figura 30. Validación seguridad D1

```
D1#sho run | include aaa|username
username admin privilege 15 secret 5 $1$iz3Y$mnwjoFEvvIVn8xD0FBiXv.
aaa new-model
aaa authentication login default local
aaa session-id common
D1#
*Apr 27 02:53:15.330: %CDP-4-DUPLEX_MISMATCH: duplex mismatch discovered on Ethernet1/1 (not full duplex), with R1 Ethernet1
```

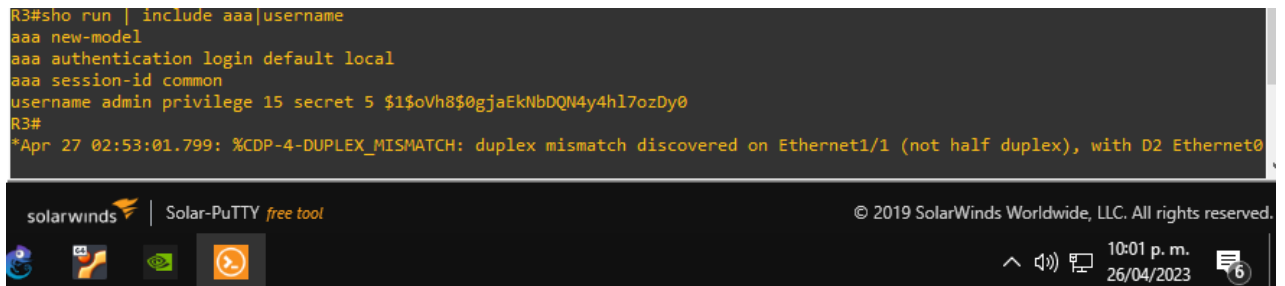
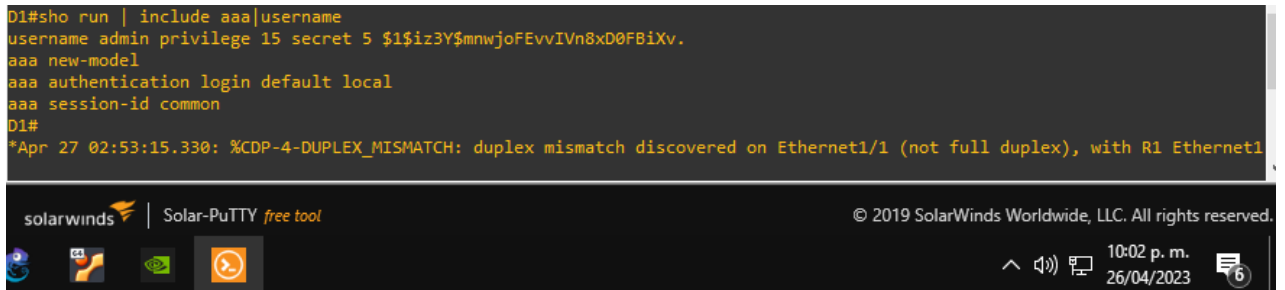

The screenshot shows a terminal window with the SolarWinds logo and 'Solar-PuTTY free tool' text. The terminal output displays the configuration for D1, including the 'username admin' command with a secret and the 'aaa authentication login default local' command. A system message at the bottom indicates a duplex mismatch on Ethernet1/1.

Figura 31. Validación seguridad D2

```
D2#sho run | include aaa|username
username admin privilege 15 secret 5 $1$wASE$Rx/Gfy3JiJI1NDNUeJRgn1
aaa new-model
aaa authentication login default local
aaa session-id common
D2#
```



The screenshot shows a terminal window with the SolarWinds logo and 'Solar-PuTTY free tool' text. The terminal output displays the configuration for D2, including the 'username admin' command with a secret and the 'aaa authentication login default local' command.

Figura 32. Validación seguridad A1

```
A1#sho run | include aaa|username
username admin privilege 15 secret 5 $1$r92x$chyrChfhDR1i.AFFqjwIs.
aaa new-model
aaa authentication login default local
aaa session-id common
A1#
```

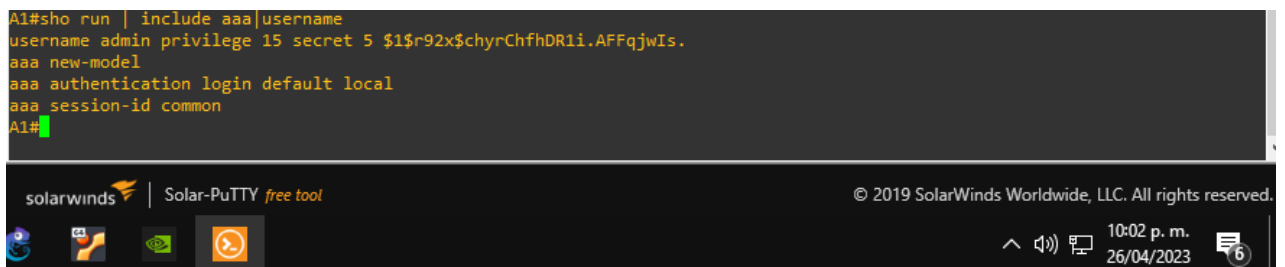

The screenshot shows a terminal window with the SolarWinds logo and 'Solar-PuTTY free tool' text. The terminal output displays the configuration for A1, including the 'username admin' command with a secret and the 'aaa authentication login default local' command.

CONCLUSIONES

Se realiza con éxito la implementación de la topología solicitada, asignando cada uno de los dispositivos acorde a las configuraciones solicitadas, configurando sus interfaces conforme a la tabla de direccionamiento.

Para la actividad se identifica la verificación y observación para la simulación de un escenario donde podemos evidenciar el funcionamiento para la configuración multi-VRF para usuarios generales y usuarios especiales.

Se logra el manejo y configuración adecuado para poner en marcha el funcionamiento del emulador GNS3, herramienta que se implementó la presente actividad.

Se realiza la configuración y creación de protocolos de seguridad para cada uno de los dispositivos montados en la red, esto con el fin de solo brindar acceso para los usuarios que se encuentren activos y con las respectivas credenciales de ingreso.

BIBLIOGRAFÍA

Edgeworth, B., Garza Rios, B., Gooley, J., Hucaby, D. (2020). CISCO Press (Ed). Packet Forwarding. CCNP and CCIE Enterprise Core ENCOR 350-401. <https://1drv.ms/b/s!AAIGg5JUgUBthk8>

Edgeworth, B., Garza Rios, B., Gooley, J., Hucaby, D. (2020). CISCO Press (Ed). IP Routing Essentials. CCNP and CCIE Enterprise Core ENCOR 350-401. <https://1drv.ms/b/s!AAIGg5JUgUBthk8>

Edgeworth, B., Garza Rios, B., Gooley, J., Hucaby, D. (2020). CISCO Press (Ed). VLAN Trunks and EtherChannel Bundles. CCNP and CCIE Enterprise Core ENCOR 350-401. <https://1drv.ms/b/s!AAIGg5JUgUBthk8>