



Diplomado De Profundización Cisco (Diseño E Implementación De Soluciones
Integradas LAN / WAN)

Evaluación – Prueba de habilidades prácticas CCNA

Michael Brayan Pinilla Coy

Presentado a:

Efraín Alejandro Pérez

Tutor

Grupo: 203092-6

Universidad Nacional Abierta y a Distancia - UNAD

Escuela de Ciencias Básicas Tecnología e Ingeniería

Diciembre de 2019

BOGOTÁ

RESUMEN

La prueba de habilidades prácticas CCNA plantea una serie de problemas que busca mediante el análisis y la teoría el planteamiento de soluciones por parte del estudiante partiendo de los conceptos aprendidos durante el curso de profundización en redes LAN/WAN. Entre los temas a destacar necesarios para el desarrollo de la actividad se encuentra el manejo y configuración de dispositivos de red, conocimiento de topologías y conocer los protocolos del modelo de referencia TCP/IP.

ABSTRACT

The CCNA practical skills test raises a series of problems that, through analysis and theory, look for the approach of solutions by the student based on the concepts learned during the course of deepening in LAN / WAN networks. Among the topics to highlight necessary for the development of the activity is the management and configuration of network devices, knowledge of topologies and knowing the protocols of the TCP / IP reference model.

INTRODUCCION

El trabajo presentado a continuación consta de una serie de actividades que tienen como propósito aplicar los conocimientos adquiridos con las fuentes de apoyo suministradas por el tutor de curso, las cuales son pieza fundamental para la realización de las actividades planteadas; dicha actividad será socializada y compartida en el entorno de aprendizaje colaborativo con el fin de conocer los distintos puntos de opinión que tienen los integrantes del grupo acerca de este

OBJETIVOS

- Incorporar hábitos y actitudes que sean de apoyo en el proceso de aprendizaje individual.
- Utilizar los conocimientos adquiridos con el fin de organizar, interpretar y dar solución a las actividades propuestas.
- Interactuar académicamente con los compañeros de grupo para abordar la metodología de trabajo en equipo.

DESARROLLO DE LOS ESCENARIOS

ESCENARIO 1

Una empresa posee sucursales distribuidas en las ciudades de Bogotá, Medellín y Cali en donde el estudiante será el administrador de la red, el cual deberá configurar e interconectar entre sí cada uno de los dispositivos que forman parte del escenario, acorde con los lineamientos establecidos para el direccionamiento IP, protocolos de enrutamiento y demás aspectos que forman parte de la topología de red.

Topología de red

Los requerimientos solicitados son los siguientes:

Parte 1: Para el direccionamiento IP debe definirse una dirección de acuerdo con el número de hosts requeridos.

Parte 2: Considerar la asignación de los parámetros básicos y la detección de vecinos directamente conectados.

Parte 3: La red y subred establecidas deberán tener una interconexión total, todos los hosts deberán ser visibles y poder comunicarse entre ellos sin restricciones.

Parte 4: Implementar la seguridad en la red, se debe restringir el acceso y comunicación entre hosts de acuerdo con los requerimientos del administrador de red.

Parte 5: Comprobación total de los dispositivos y su funcionamiento en la red. Parte 6: Configuración final.

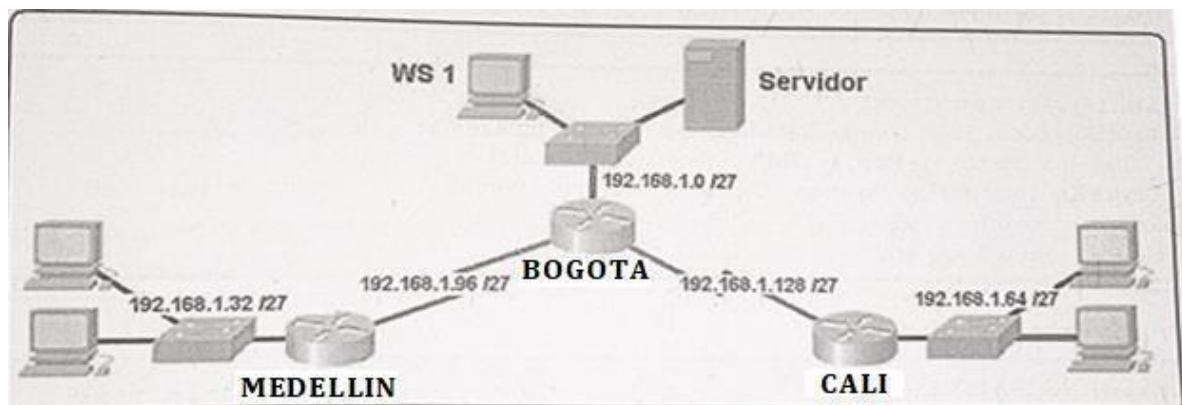
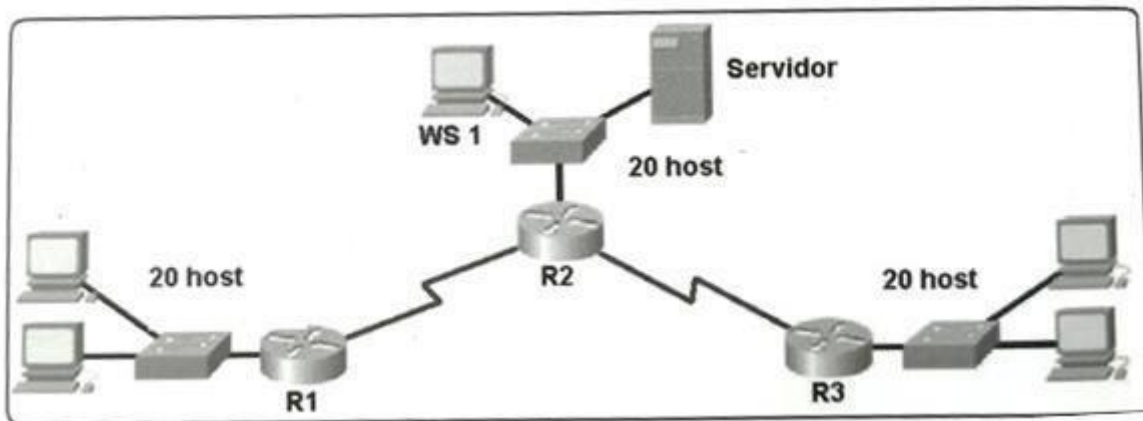

DESARROLLO

Como trabajo inicial se debe realizar lo siguiente.

- Realizar las rutinas de diagnóstico y dejar los equipos listos para su configuración (asignar nombres de equipos, asignar claves de seguridad, etc).

□ Realizar la conexión física de los equipos con base en la topología de red. Configurar la topología de red, de acuerdo con las siguientes especificaciones.

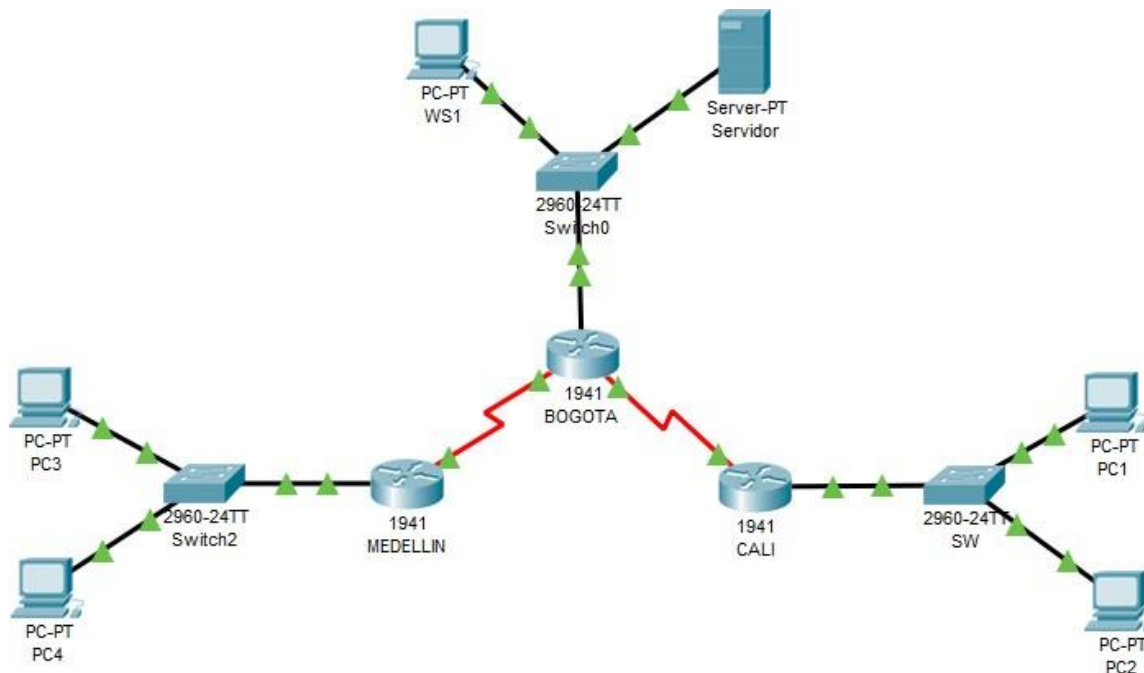

Parte 1: Asignación de direcciones IP:

- a. Se debe dividir (subnetear) la red creando una segmentación en ocho partes, para permitir crecimiento futuro de la red corporativa.
- b. Asignar una dirección IP a la red.

Parte 2: Configuración Básica.

- a. Completar la siguiente tabla con la configuración básica de los routers, teniendo en cuenta las subredes diseñadas.

	R1	R2	R3
Nombre de Host	MEDELLIN	BOGOTA	CALI
Dirección de Ip en interfaz Serial 0/0	192.168.1.99	192.168.1.98	192.168.1.31
Dirección de Ip en interfaz Serial 0/1		192.168.1.130	
Dirección de Ip en interfaz FA 0/0	192.168.1.33	192.168.1.1	192.168.1.65

	R1	R2	R3
Nombre de Host	MEDELLIN	BOGOTA	CALI
Protocolo de enrutamiento	Eigrp	Eigrp	Eigrp
Sistema Autónomo	200	200	200
Afirmaciones de red	192.168.1.0	192.168.1.0	192.168.1.0

b. Después de cargada la configuración en los dispositivos, verificar la tabla de enrutamiento en cada uno de los routers para comprobar las redes y sus rutas.

MEDELLIN

The screenshot shows a window titled 'MEDELLIN' with tabs for 'Physical', 'Config', 'CLI', and 'Attributes'. The 'CLI' tab is active, displaying the 'IOS Command Line Interface'. The terminal output shows the following commands and their results:

```

Router#
%SYS-5-CONFIG_I: Configured from console by console

Router#
Router#
Router#show
Router#show ip
Router#show ip rou
Router#show ip route

Codes: L - local, C - connected, S - static, R - RIP, M - mobile, B - BGP
       D - EIGRP, EX - EIGRP external, O - OSPF, IA - OSPF inter area
       N1 - OSPF NSSA external type 1, N2 - OSPF NSSA external type 2
       E1 - OSPF external type 1, E2 - OSPF external type 2, E - EGP
       i - IS-IS, L1 - IS-IS level-1, L2 - IS-IS level-2, ia - IS-IS inter area
       * - candidate default, U - per-user static route, o - ODR
       P - periodic downloaded static route

Gateway of last resort is not set

    192.168.1.0/24 is variably subnetted, 4 subnets, 2 masks
C       192.168.1.32/27 is directly connected, GigabitEthernet0/0
L       192.168.1.33/32 is directly connected, GigabitEthernet0/0
C       192.168.1.96/27 is directly connected, Serial0/0/0
L       192.168.1.99/32 is directly connected, Serial0/0/0

Router#
  
```

At the bottom of the window, there is a prompt 'Ctrl+F6 to exit CLI focus' and two buttons: 'Copy' and 'Paste'.



BOGOTA

BOGOTA

Physical Config **CLI** Attributes

IOS Command Line Interface

```
Router(config-if)#
Router(config-if)#
Router(config-if)#EXIT
Router(config)#
Router(config)#EXIT
Router#
%SYS-5-CONFIG_I: Configured from console by console

Router#
Router#sho
Router#show ip
Router#show ip ro
Router#show ip route
Codes: L - local, C - connected, S - static, R - RIP, M - mobile, B - BGP
D - EIGRP, EX - EIGRP external, O - OSPF, IA - OSPF inter area
N1 - OSPF NSSA external type 1, N2 - OSPF NSSA external type 2
E1 - OSPF external type 1, E2 - OSPF external type 2, E - EGP
i - IS-IS, L1 - IS-IS level-1, L2 - IS-IS level-2, ia - IS-IS inter area
* - candidate default, U - per-user static route, o - ODR
P - periodic downloaded static route

Gateway of last resort is not set

 192.168.1.0/24 is variably subnetted, 6 subnets, 2 masks
C    192.168.1.0/27 is directly connected, GigabitEthernet0/0
L    192.168.1.1/32 is directly connected, GigabitEthernet0/0
C    192.168.1.96/27 is directly connected, Serial0/0/0
L    192.168.1.98/32 is directly connected, Serial0/0/0
C    192.168.1.128/27 is directly connected, Serial0/0/1
L    192.168.1.130/32 is directly connected, Serial0/0/1

Router#
```

Ctrl+F6 to exit CLI focus

Copy Paste

CALI

CALI

Physical Config **CLI** Attributes

IOS Command Line Interface

```
Router>
Router>
Router>
Router>enable
Router>enable
Router#
Router#show ip
Router#show ip rou
Router#show ip route
Codes: L - local, C - connected, S - static, R - RIP, M - mobile, B - BGP
D - EIGRP, EX - EIGRP external, O - OSPF, IA - OSPF inter area
N1 - OSPF NSSA external type 1, N2 - OSPF NSSA external type 2
E1 - OSPF external type 1, E2 - OSPF external type 2, E - EGP
i - IS-IS, L1 - IS-IS level-1, L2 - IS-IS level-2, ia - IS-IS inter area
* - candidate default, U - per-user static route, o - ODR
P - periodic downloaded static route

Gateway of last resort is not set

 192.168.1.0/24 is variably subnetted, 4 subnets, 2 masks
C    192.168.1.64/27 is directly connected, GigabitEthernet0/0
L    192.168.1.65/32 is directly connected, GigabitEthernet0/0
C    192.168.1.128/27 is directly connected, Serial0/0/1
L    192.168.1.131/32 is directly connected, Serial0/0/1

Router#
```

Ctrl+F6 to exit CLI focus

Copy Paste

- Verificar el balanceo de carga que presentan los routers.

MEDELLIN

MEDELLIN

Physical Config **CLI** Attributes

IOS Command Line Interface

```

Router#show cd
Router#show cdp ne
Router#show cdp neighbors
Capability Codes: R - Router, T - Trans Bridge, B - Source Route Bridge
                  S - Switch, H - Host, I - IGMP, r - Repeater, P - Phone
Device ID      Local Intrfce  Holdtme  Capability  Platform  Port ID
Router        Ser 0/0/0      154      R           Cl900     Ser 0/0/0
Switch        Gig 0/0        135      S           2960      Fas 0/1
Router#
Router#
Router#
Router#
Router#pi
Router#ping 192.168.1.131

Type escape sequence to abort.
Sending 5, 100-byte ICMP Echos to 192.168.1.131, timeout is 2 seconds:
.....
Success rate is 0 percent (0/5)

Router#
Router#ping 192.168.1.98

Type escape sequence to abort.
Sending 5, 100-byte ICMP Echos to 192.168.1.98, timeout is 2 seconds:
!!!!!!
Success rate is 100 percent (5/5), round-trip min/avg/max = 1/5/24 ms

Router#
    
```

Ctrl+F6 to exit CLI focus

Copy Paste

BOGOTA

BOGOTA

Physical Config **CLI** Attributes

IOS Command Line Interface

```

192.168.1.0/24 is variably subnetted, 6 subnets, 2 masks
C    192.168.1.0/27 is directly connected, GigabitEthernet0/0
L    192.168.1.1/32 is directly connected, GigabitEthernet0/0
C    192.168.1.96/27 is directly connected, Serial0/0/0
L    192.168.1.98/32 is directly connected, Serial0/0/0
C    192.168.1.128/27 is directly connected, Serial0/0/1
L    192.168.1.130/32 is directly connected, Serial0/0/1

Router#
Router#
Router#show ip route 192.168.1.98
Routing entry for 192.168.1.98/32

Router#show ip route 192.168.1.96
Routing entry for 192.168.1.96/27
Known via "connected", distance 0, metric 0 (connected, via interface)
  Routing Descriptor Blocks:
    * directly connected, via Serial0/0/0
      Route metric is 0, traffic share count is 1

Router#show ip route 192.168.1.128
Routing entry for 192.168.1.128/27
Known via "connected", distance 0, metric 0 (connected, via interface)
  Routing Descriptor Blocks:
    * directly connected, via Serial0/0/1
      Route metric is 0, traffic share count is 1

Router#
    
```

Ctrl+F6 to exit CLI focus

Copy Paste

CALI

Physical Config **CLI** Attributes

IOS Command Line Interface

```

i - IS-IS, L1 - IS-IS level-1, L2 - IS-IS level-2, ia - IS-IS
inter area
* - candidate default, U - per-user static route, o - ODR
P - periodic downloaded static route

Gateway of last resort is not set

192.168.1.0/24 is variably subnetted, 4 subnets, 2 masks
C 192.168.1.64/27 is directly connected, GigabitEthernet0/0
L 192.168.1.65/32 is directly connected, GigabitEthernet0/0
C 192.168.1.128/27 is directly connected, Serial0/0/1
L 192.168.1.131/32 is directly connected, Serial0/0/1

Router#show ip route 192.168.1.131
Routing entry for 192.168.1.131/32

Router#show ip route 192.168.1.128
Routing entry for 192.168.1.128/27
Known via "connected", distance 0, metric 0 (connected, via
interface)
Routing Descriptor Blocks:
* directly connected, via Serial0/0/1
Route metric is 0, traffic share count is 1

Router#
    
```

Ctrl+F6 to exit CLI focus

Copy Paste

c. Realizar un diagnóstico de vecinos usando el comando cdp.

CALI

Physical Config **CLI** Attributes

IOS Command Line Interface

```

i - IS-IS, L1 - IS-IS level-1, L2 - IS-IS level-2, ia - IS-IS inter area
* - candidate default, U - per-user static route, o - ODR
P - periodic downloaded static route

Gateway of last resort is not set

192.168.1.0/24 is variably subnetted, 4 subnets, 2 masks
C 192.168.1.64/27 is directly connected, GigabitEthernet0/0
L 192.168.1.65/32 is directly connected, GigabitEthernet0/0
C 192.168.1.128/27 is directly connected, Serial0/0/1
L 192.168.1.131/32 is directly connected, Serial0/0/1

Router#
Router#
Router#
Router#show
Router#show cd
Router#show cdp ne
Router#show cdp neighbors
Capability Codes: R - Router, T - Trans Bridge, B - Source Route Bridge
S - Switch, H - Host, I - IGMP, r - Repeater, P - Phone
Device ID Local Intrfce Holdtme Capability Platform Port ID
Switch Gig 0/0 132 S 2960 Fas 0/1
Router Ser 0/0/1 179 R C1900 Ser 0/0/1

Router#
Router#
    
```

Ctrl+F6 to exit CLI focus

Copy Paste

Top

BOGOTA

BOGOTA
— □ ×

Physical
Config
CLI
Attributes

IOS Command Line Interface

```

N1 - OSPF NSSA external type 1, N2 - OSPF NSSA external type 2
E1 - OSPF external type 1, E2 - OSPF external type 2, E - EGP
i - IS-IS, L1 - IS-IS level-1, L2 - IS-IS level-2, ia - IS-IS inter area
* - candidate default, U - per-user static route, o - ODR
P - periodic downloaded static route

Gateway of last resort is not set

192.168.1.0/24 is variably subnetted, 6 subnets, 2 masks
C   192.168.1.0/27 is directly connected, GigabitEthernet0/0
L   192.168.1.1/32 is directly connected, GigabitEthernet0/0
C   192.168.1.96/27 is directly connected, Serial0/0/0
L   192.168.1.98/32 is directly connected, Serial0/0/0
C   192.168.1.128/27 is directly connected, Serial0/0/1
L   192.168.1.130/32 is directly connected, Serial0/0/1

Router#
Router#
Router#
Router#sw
Router#show
Router#show cd
Router#show cdp ne
Router#show cdp neighbors
Capability Codes: R - Router, T - Trans Bridge, B - Source Route Bridge
                  S - Switch, H - Host, I - IGMP, r - Repeater, P - Phone
Device ID        Local Intrfce Holdtme  Capability Platform  Port ID
Router          Ser 0/0/1      134      R           C1900     Ser 0/0/1
Router          Ser 0/0/0      139      R           C1900     Ser 0/0/0
Switch         Gig 0/0        154      S           2960     Fas 0/1
Router#

```

Ctrl+F6 to exit CLI focus
Copy Paste

MEDELLIN

MEDELLIN
— □ ×

Physical
Config
CLI
Attributes

IOS Command Line Interface

```

Router#show ip route
Codes: L - local, C - connected, S - static, R - RIP, M - mobile, B - BGP
       D - EIGRP, EX - EIGRP external, O - OSPF, IA - OSPF inter area
       N1 - OSPF NSSA external type 1, N2 - OSPF NSSA external type 2
       E1 - OSPF external type 1, E2 - OSPF external type 2, E - EGP
       i - IS-IS, L1 - IS-IS level-1, L2 - IS-IS level-2, ia - IS-IS inter area
       * - candidate default, U - per-user static route, o - ODR
       P - periodic downloaded static route

Gateway of last resort is not set

192.168.1.0/24 is variably subnetted, 4 subnets, 2 masks
C   192.168.1.32/27 is directly connected, GigabitEthernet0/0
L   192.168.1.33/32 is directly connected, GigabitEthernet0/0
C   192.168.1.96/27 is directly connected, Serial0/0/0
L   192.168.1.99/32 is directly connected, Serial0/0/0

Router#
Router#
Router#sho
Router#show cd
Router#show cdp ne
Router#show cdp neighbors
Capability Codes: R - Router, T - Trans Bridge, B - Source Route Bridge
                  S - Switch, H - Host, I - IGMP, r - Repeater, P - Phone
Device ID        Local Intrfce Holdtme  Capability Platform  Port ID
Router          Ser 0/0/0      154      R           C1900     Ser 0/0/0
Switch         Gig 0/0        139      S           2960     Fas 0/1
Router#

```

Ctrl+F6 to exit CLI focus
Copy Paste

d. Realizar una prueba de conectividad en cada tramo de la ruta usando Ping.

Se hace ping entre las ciudades de Bogotá y Medellín desde el enrutador y hay una respuesta afirmativa, sin embargo, al realizar un ping entre las ciudades de Medellín y Cali no hay conectividad debido a que en la tabla de enrutamiento no es posible identificar una ruta asociada a la ciudad de Cali.

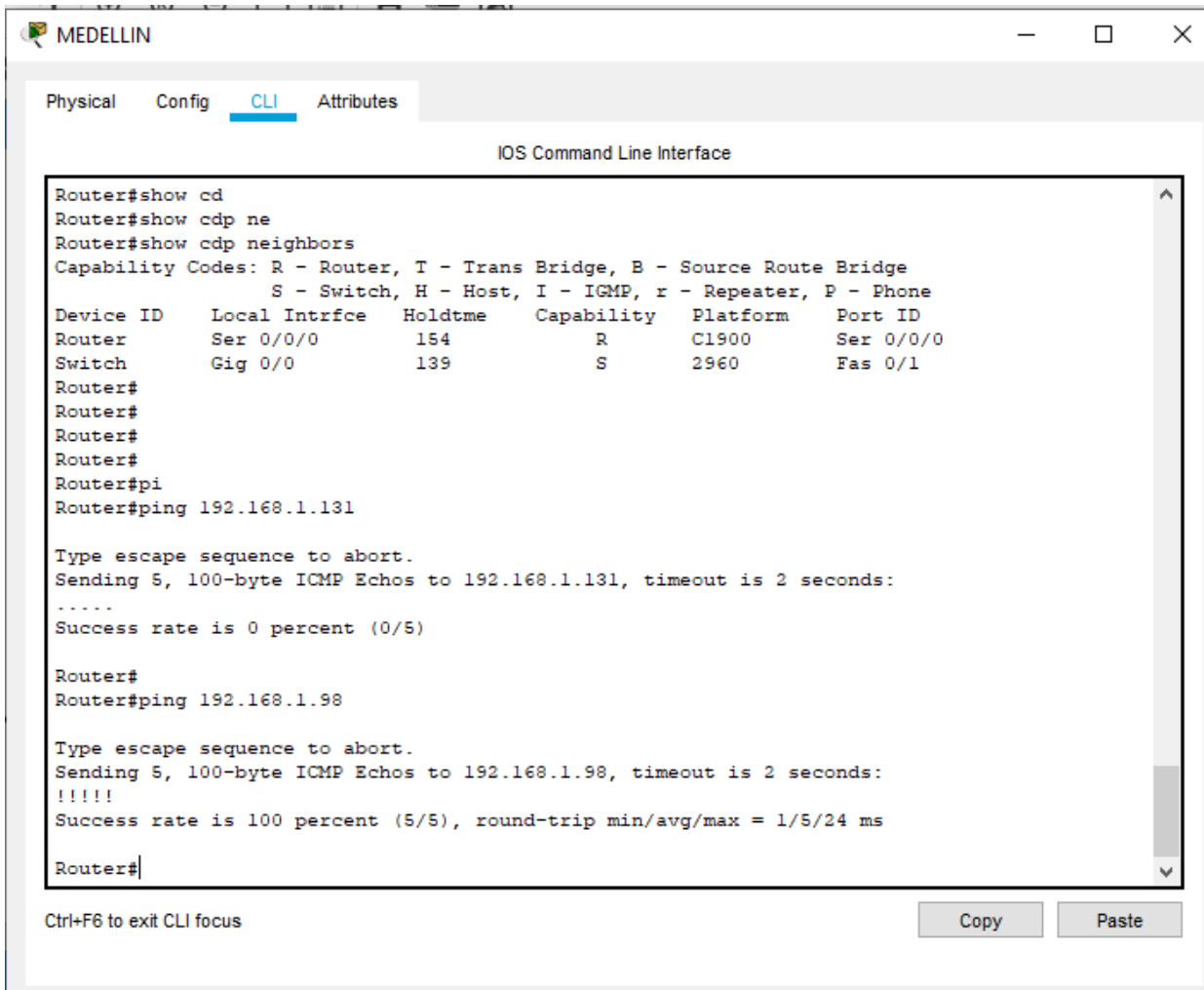

```

Router#show cd
Router#show cdp ne
Router#show cdp neighbors
Capability Codes: R - Router, T - Trans Bridge, B - Source Route Bridge
                  S - Switch, H - Host, I - IGMP, r - Repeater, P - Phone
Device ID      Local Interface  Holdtime  Capability  Platform  Port ID
Router         Ser 0/0/0        154       R           C1900     Ser 0/0/0
Switch        Gig 0/0          139       S           2960     Fas 0/1
Router#
Router#
Router#
Router#
Router#pi
Router#ping 192.168.1.131

Type escape sequence to abort.
Sending 5, 100-byte ICMP Echos to 192.168.1.131, timeout is 2 seconds:
.....
Success rate is 0 percent (0/5)

Router#
Router#ping 192.168.1.98

Type escape sequence to abort.
Sending 5, 100-byte ICMP Echos to 192.168.1.98, timeout is 2 seconds:
!!!!
Success rate is 100 percent (5/5), round-trip min/avg/max = 1/5/24 ms

Router#
  
```

Parte 3: Configuración de Enrutamiento.

a. Asignar el protocolo de enrutamiento EIGRP a los routers considerando el direccionamiento diseñado.

CALI

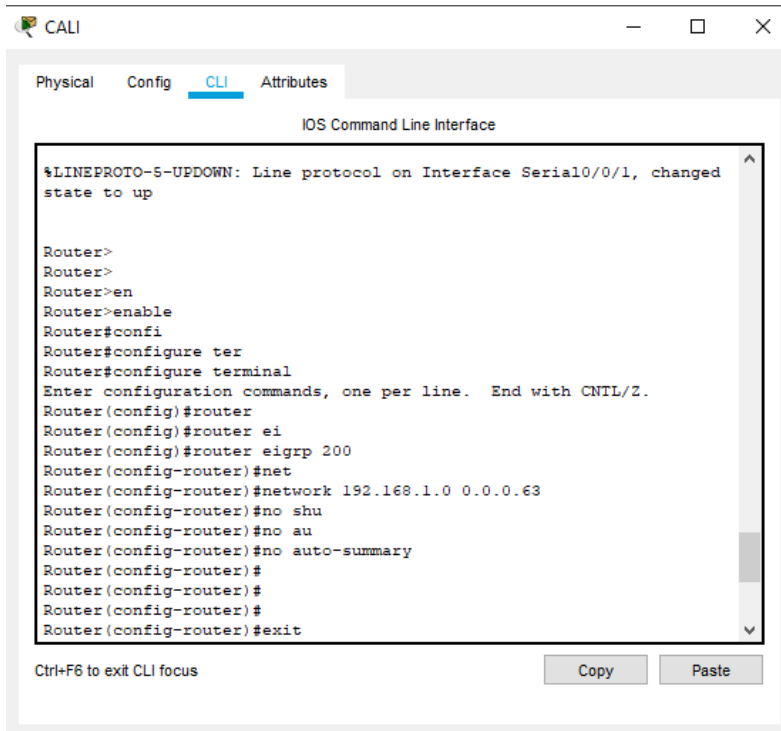

The screenshot shows the CALI application window with the CLI tab selected. The terminal output displays the following commands and their results:

```
%LINEPROTO-5-UPDOWN: Line protocol on Interface Serial0/0/1, changed state to up

Router>
Router>
Router>en
Router>enable
Router#confi
Router#configure ter
Router#configure terminal
Enter configuration commands, one per line. End with CNTL/Z.
Router(config)#router
Router(config)#router ei
Router(config)#router eigrp 200
Router(config-router)#net
Router(config-router)#network 192.168.1.0 0.0.0.63
Router(config-router)#no shu
Router(config-router)#no au
Router(config-router)#no auto-summary
Router(config-router)#
Router(config-router)#
Router(config-router)#
Router(config-router)#exit
```

At the bottom of the window, there is a status bar with the text "Ctrl+F6 to exit CLI focus" and two buttons labeled "Copy" and "Paste".

MEDELLIN

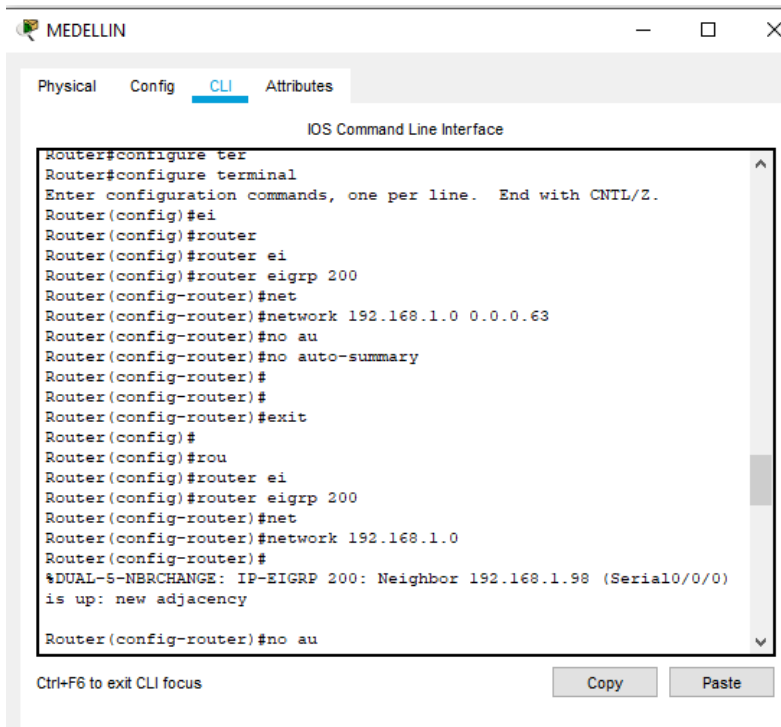

The screenshot shows the MEDELLIN application window with the CLI tab selected. The terminal output displays the following commands and their results:

```
Router#configure ter
Router#configure terminal
Enter configuration commands, one per line. End with CNTL/Z.
Router(config)#ei
Router(config)#router
Router(config)#router ei
Router(config)#router eigrp 200
Router(config-router)#net
Router(config-router)#network 192.168.1.0 0.0.0.63
Router(config-router)#no au
Router(config-router)#no auto-summary
Router(config-router)#
Router(config-router)#
Router(config-router)#exit
Router(config)#
Router(config)#rou
Router(config)#router ei
Router(config)#router eigrp 200
Router(config-router)#net
Router(config-router)#network 192.168.1.0
Router(config-router)#
%DUAL-5-NBRCHANGE: IP-EIGRP 200: Neighbor 192.168.1.98 (Serial0/0/0)
is up: new adjacency

Router(config-router)#no au
```

At the bottom of the window, there is a status bar with the text "Ctrl+F6 to exit CLI focus" and two buttons labeled "Copy" and "Paste".

BOGOTA

```

IOS Command Line Interface

Router(config-router)#no au
Router(config-router)#no auto-summary
Router(config-router)#exit
Router(config)#
Router(config)#rou
Router(config)#router ei
Router(config)#router eigrp 200
Router(config-router)#net
Router(config-router)#network 192.168.1.0
Router(config-router)#
%DUAL-5-NBRCHANGE: IP-EIGRP 200: Neighbor 192.168.1.131 (Serial0/0/1)
is up: new adjacency

Router(config-router)#
Router(config-router)#no au
Router(config-router)#no auto-summary
Router(config-router)#
%DUAL-5-NBRCHANGE: IP-EIGRP 200: Neighbor 192.168.1.99 (Serial0/0/0)
is up: new adjacency

Router(config-router)#
Router(config-router)#
Router(config-router)#
Router(config-router)#exit
Router(config)#
  
```

Ctrl+F6 to exit CLI focus

Copy Paste

b. Verificar si existe vecindad con los routers configurados con EIGRP.

BOGOTA

```

IOS Command Line Interface

Gateway of last resort is not set

192.168.1.0/24 is variably subnetted, 8 subnets, 2 masks
C   192.168.1.0/27 is directly connected, GigabitEthernet0/0
L   192.168.1.1/32 is directly connected, GigabitEthernet0/0
D   192.168.1.32/27 [90/2172416] via 192.168.1.99, 00:03:26, Serial0/0/0
D   192.168.1.64/27 [90/2172416] via 192.168.1.131, 00:03:50, Serial0/0/1
C   192.168.1.96/27 is directly connected, Serial0/0/0
L   192.168.1.99/32 is directly connected, Serial0/0/0
C   192.168.1.128/27 is directly connected, Serial0/0/1
L   192.168.1.130/32 is directly connected, Serial0/0/1

Router#
Router#
Router#
Router#
Router#show cd
Router#show cdp ne
Router#show cdp neighbors
Capability Codes: R - Router, T - Trans Bridge, B - Source Route Bridge
                  S - Switch, H - Host, I - IGMP, r - Repeater, P - Phone
Device ID      Local Intrfce  Holdtme  Capability  Platform  Port ID
Switch        Gig 0/0        155      S           2960      Fas 0/1
Router        Ser 0/0/1      155      R           Cl900     Ser 0/0/1
Router        Ser 0/0/0      155      R           Cl900     Ser 0/0/0
Router#
  
```

Ctrl+F6 to exit CLI focus

Copy Paste

MEDELLIN

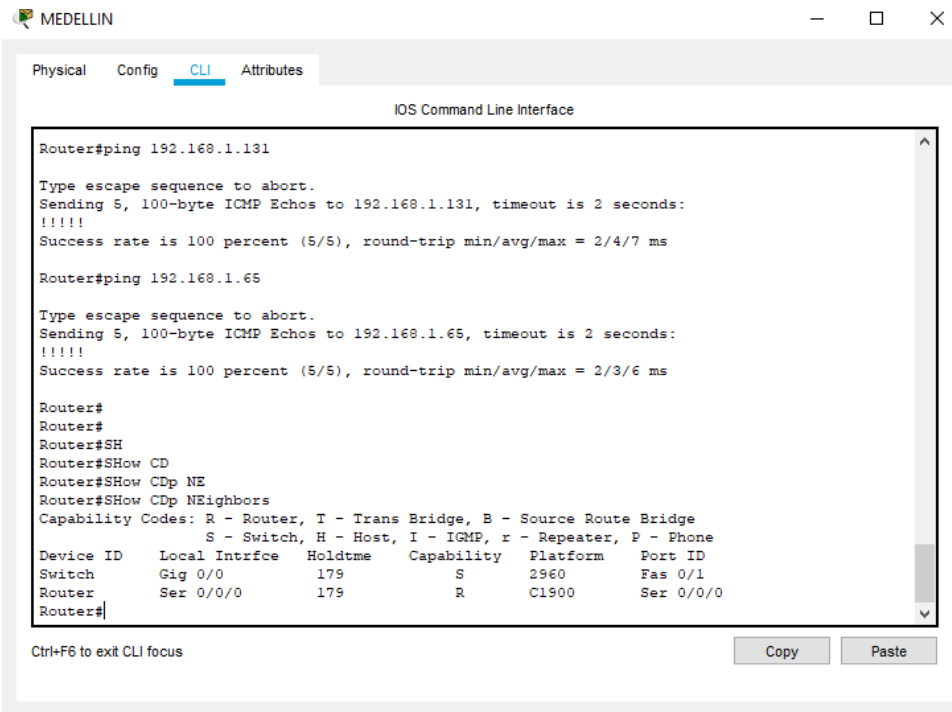

MEDELLIN

Physical Config **CLI** Attributes

IOS Command Line Interface

```
Router#ping 192.168.1.131
Type escape sequence to abort.
Sending 5, 100-byte ICMP Echos to 192.168.1.131, timeout is 2 seconds:
!!!!
Success rate is 100 percent (5/5), round-trip min/avg/max = 2/4/7 ms

Router#ping 192.168.1.65
Type escape sequence to abort.
Sending 5, 100-byte ICMP Echos to 192.168.1.65, timeout is 2 seconds:
!!!!
Success rate is 100 percent (5/5), round-trip min/avg/max = 2/3/6 ms

Router#
Router#
Router#SH
Router#SHoW CD
Router#SHoW Cdp NE
Router#SHoW Cdp NEighbors
Capability Codes: R - Router, T - Trans Bridge, B - Source Route Bridge
                  S - Switch, H - Host, I - IGMP, r - Repeater, P - Phone
Device ID      Local Intrfce  Holdtme  Capability  Platform  Port ID
Switch        Gig 0/0        179      S           2960      Fas 0/1
Router        Ser 0/0/0      179      R           C1900     Ser 0/0/0
Router#
```

Ctrl+F6 to exit CLI focus

Copy Paste

CALI

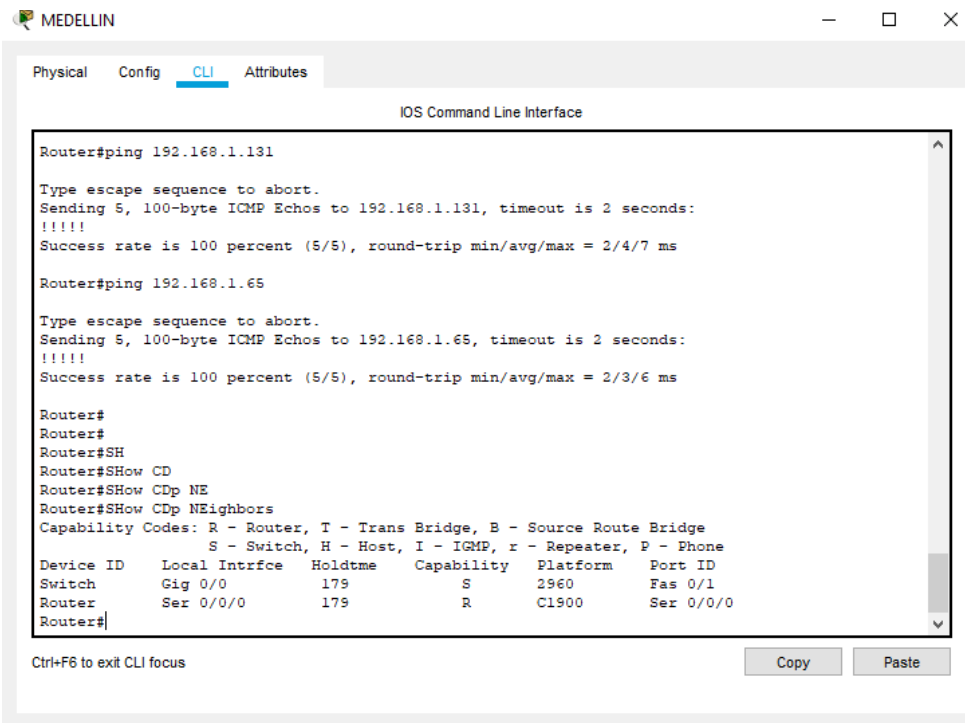

MEDELLIN

Physical Config **CLI** Attributes

IOS Command Line Interface

```
Router#ping 192.168.1.131
Type escape sequence to abort.
Sending 5, 100-byte ICMP Echos to 192.168.1.131, timeout is 2 seconds:
!!!!
Success rate is 100 percent (5/5), round-trip min/avg/max = 2/4/7 ms

Router#ping 192.168.1.65
Type escape sequence to abort.
Sending 5, 100-byte ICMP Echos to 192.168.1.65, timeout is 2 seconds:
!!!!
Success rate is 100 percent (5/5), round-trip min/avg/max = 2/3/6 ms

Router#
Router#
Router#SH
Router#SHoW CD
Router#SHoW Cdp NE
Router#SHoW Cdp NEighbors
Capability Codes: R - Router, T - Trans Bridge, B - Source Route Bridge
                  S - Switch, H - Host, I - IGMP, r - Repeater, P - Phone
Device ID      Local Intrfce  Holdtme  Capability  Platform  Port ID
Switch        Gig 0/0        179      S           2960      Fas 0/1
Router        Ser 0/0/0      179      R           C1900     Ser 0/0/0
Router#
```

Ctrl+F6 to exit CLI focus

Copy Paste

- Realizar la comprobación de las tablas de enrutamiento en cada uno de los routers para verificar cada una de las rutas establecidas.

BOGOTA

The screenshot shows the CLI interface of a router named BOGOTA. The 'CLI' tab is active, displaying the following routing table information:

```

BGP
  D - EIGRP, EX - EIGRP external, O - OSPF, IA - OSPF inter area
  N1 - OSPF NSSA external type 1, N2 - OSPF NSSA external type 2
  E1 - OSPF external type 1, E2 - OSPF external type 2, E - EGP
  i - IS-IS, L1 - IS-IS level-1, L2 - IS-IS level-2, ia - IS-IS
inter area
  * - candidate default, U - per-user static route, o - ODR
  P - periodic downloaded static route

Gateway of last resort is not set

  192.168.1.0/24 is variably subnetted, 8 subnets, 2 masks
C    192.168.1.0/27 is directly connected, GigabitEthernet0/0
L    192.168.1.1/32 is directly connected, GigabitEthernet0/0
D    192.168.1.32/27 [90/2172416] via 192.168.1.99, 00:12:48,
Serial0/0/0
D    192.168.1.64/27 [90/2172416] via 192.168.1.131, 00:13:12,
Serial0/0/1
C    192.168.1.96/27 is directly connected, Serial0/0/0
L    192.168.1.98/32 is directly connected, Serial0/0/0
C    192.168.1.128/27 is directly connected, Serial0/0/1
L    192.168.1.130/32 is directly connected, Serial0/0/1

Router#
Router#
  
```

MEDELLIN

The screenshot shows the CLI interface of a router named MEDELLIN. The 'CLI' tab is active, displaying the following routing table information:

```

Router#
Router#
Router#
Router#
Router#show ip rou
Router#show ip route
Codes: L - local, C - connected, S - static, R - RIP, M - mobile, B - BGP
       D - EIGRP, EX - EIGRP external, O - OSPF, IA - OSPF inter area
       N1 - OSPF NSSA external type 1, N2 - OSPF NSSA external type 2
       E1 - OSPF external type 1, E2 - OSPF external type 2, E - EGP
       i - IS-IS, L1 - IS-IS level-1, L2 - IS-IS level-2, ia - IS-IS inter area
       * - candidate default, U - per-user static route, o - ODR
       P - periodic downloaded static route

Gateway of last resort is not set

  192.168.1.0/24 is variably subnetted, 7 subnets, 2 masks
D    192.168.1.0/27 [90/2172416] via 192.168.1.98, 00:13:24, Serial0/0/0
C    192.168.1.32/27 is directly connected, GigabitEthernet0/0
L    192.168.1.33/32 is directly connected, GigabitEthernet0/0
D    192.168.1.64/27 [90/2684416] via 192.168.1.98, 00:13:24, Serial0/0/0
C    192.168.1.96/27 is directly connected, Serial0/0/0
L    192.168.1.99/32 is directly connected, Serial0/0/0
D    192.168.1.128/27 [90/2681856] via 192.168.1.98, 00:13:24, Serial0/0/0

Router#
Router#
  
```

CALI

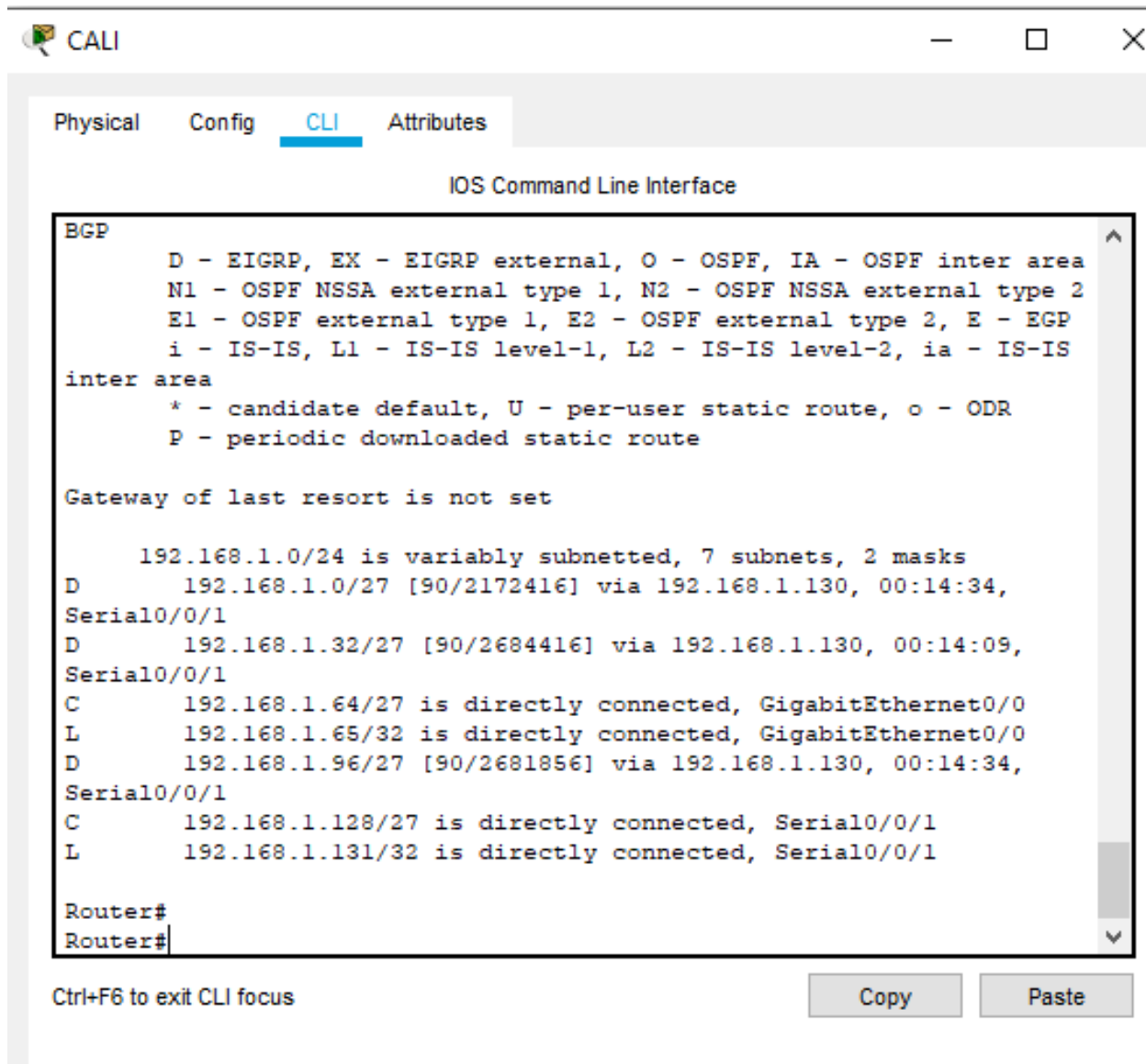

The screenshot shows the CALI CLI interface with the following content:

```

BGP
  D - EIGRP, EX - EIGRP external, O - OSPF, IA - OSPF inter area
  N1 - OSPF NSSA external type 1, N2 - OSPF NSSA external type 2
  E1 - OSPF external type 1, E2 - OSPF external type 2, E - EGP
  i - IS-IS, L1 - IS-IS level-1, L2 - IS-IS level-2, ia - IS-IS
inter area
  * - candidate default, U - per-user static route, o - ODR
  P - periodic downloaded static route

Gateway of last resort is not set

    192.168.1.0/24 is variably subnetted, 7 subnets, 2 masks
D       192.168.1.0/27 [90/2172416] via 192.168.1.130, 00:14:34,
Serial0/0/1
D       192.168.1.32/27 [90/2684416] via 192.168.1.130, 00:14:09,
Serial0/0/1
C       192.168.1.64/27 is directly connected, GigabitEthernet0/0
L       192.168.1.65/32 is directly connected, GigabitEthernet0/0
D       192.168.1.96/27 [90/2681856] via 192.168.1.130, 00:14:34,
Serial0/0/1
C       192.168.1.128/27 is directly connected, Serial0/0/1
L       192.168.1.131/32 is directly connected, Serial0/0/1

Router#
Router#
  
```

Below the terminal window, there is a status bar with the text "Ctrl+F6 to exit CLI focus" and two buttons: "Copy" and "Paste".

c. Realizar un diagnóstico para comprobar que cada uno de los puntos de la red se puedan ver y tengan conectividad entre sí. Realizar esta prueba desde un host de la red LAN del router CALI, primero a la red de MEDELLIN y luego al servidor.

PC1

Physical Config **Desktop** Programming Attributes

```

Command Prompt
Pinging 192.168.1.34 with 32 bytes of data:

Reply from 192.168.1.34: bytes=32 time=2ms TTL=125
Reply from 192.168.1.34: bytes=32 time=11ms TTL=125
Reply from 192.168.1.34: bytes=32 time=2ms TTL=125
Reply from 192.168.1.34: bytes=32 time=13ms TTL=125

Ping statistics for 192.168.1.34:
    Packets: Sent = 4, Received = 4, Lost = 0 (0% loss),
    Approximate round trip times in milli-seconds:
        Minimum = 2ms, Maximum = 13ms, Average = 7ms

C:\>ping 192.168.1.2

Pinging 192.168.1.2 with 32 bytes of data:

Request timed out.
Reply from 192.168.1.2: bytes=32 time=1ms TTL=126
Reply from 192.168.1.2: bytes=32 time=11ms TTL=126
Reply from 192.168.1.2: bytes=32 time=1ms TTL=126

Ping statistics for 192.168.1.2:
    Packets: Sent = 4, Received = 3, Lost = 1 (25% loss),
    Approximate round trip times in milli-seconds:
        Minimum = 1ms, Maximum = 11ms, Average = 4ms

C:\>
  
```

Top

Parte 4: Configuración de las listas de Control de Acceso.

En este momento cualquier usuario de la red tiene acceso a todos sus dispositivos y estaciones de trabajo. El jefe de redes le solicita implementar seguridad en la red. Para esta labor se decide configurar listas de control de acceso (ACL) a los routers.



Las condiciones para crear las ACL son las siguientes:

- a. Cada router debe estar habilitado para establecer conexiones Telnet con los demás routers y tener acceso a cualquier dispositivo en la red.
- b. El equipo WS1 y el servidor se encuentran en la subred de administración. Solo el servidor de la subred de administración debe tener acceso a cualquier otro dispositivo en cualquier parte de la red.
- c. Las estaciones de trabajo en las LAN de MEDELLIN y CALI no deben tener acceso a ningún dispositivo fuera de su subred, excepto para interconectar con el servidor.

Parte 5: Comprobación de la red instalada.

- a. Se debe probar que la configuración de las listas de acceso fue exitosa.
- b. Comprobar y Completar la siguiente tabla de condiciones de prueba para confirmar el óptimo funcionamiento de la red e.

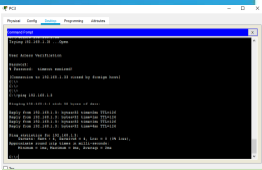
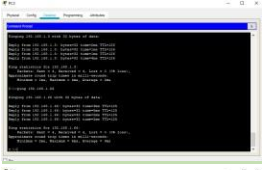
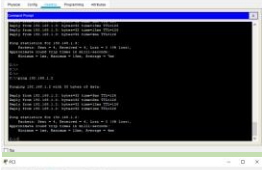
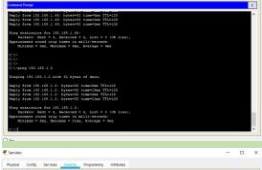
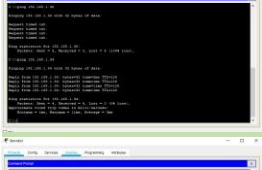
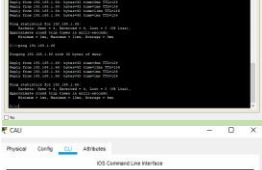
	ORIGEN	DESTINO	RESULTADO
TELNET	Router MEDELLIN	Router CALI	
	WS_1	Router BOGOTA	
	Servidor	Router CALI	
	Servidor	Router MEDELLIN	
TELNET	LAN del Router MEDELLIN	Router CALI	
	LAN del Router CALI	Router CALI	
	LAN del Router MEDELLIN	Router MEDELLIN	
	LAN del Router CALI	Router MEDELLIN	
PING	LAN del Router CALI	WS_1	

	LAN del Router MEDELLIN	WS_1	
	LAN del Router MEDELLIN	LAN del Router CALI	
PING	LAN del Router CALI	Servidor	
	LAN del Router MEDELLIN	Servidor	
	Servidor	LAN del Router MEDELLIN	
	Servidor	LAN del Router CALI	
	Router CALI	LAN del Router MEDELLIN	
	Router MEDELLIN	LAN del Router CALI	

ESCENARIO 2

Una empresa tiene la conexión a internet en una red Ethernet, lo cual deben adaptarlo para facilitar que sus routers y las redes que incluyen puedan, por esa vía, conectarse a internet, pero empleando las direcciones de la red LAN original.

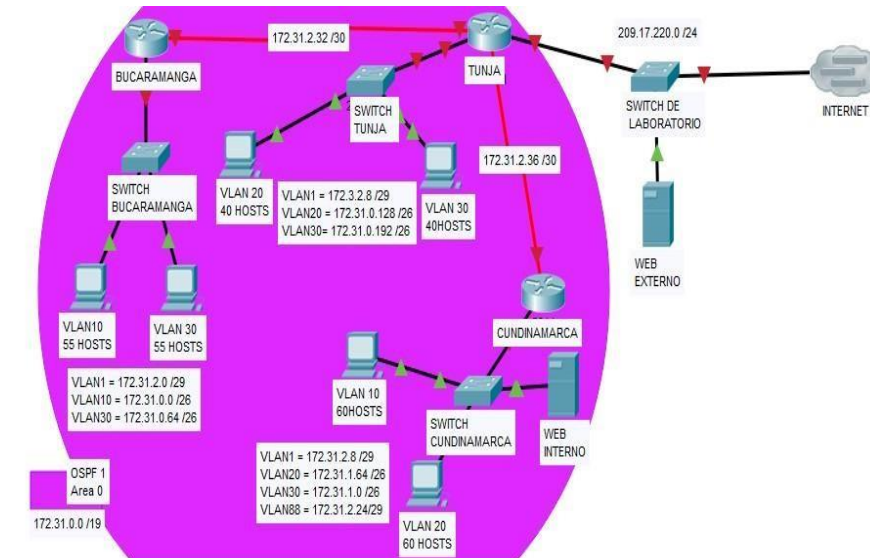

Desarrollo

Los siguientes son los requerimientos necesarios:

1. Todos los routers deberán tener los siguiente:
 - Configuración básica.
 - Autenticación local con AAA.
 - Cifrado de contraseñas.
 - Un máximo de internos para acceder al router.
 - Máximo tiempo de acceso al detectar ataques.
 - Establezca un servidor TFTP y almacene todos los archivos necesarios de los routers.

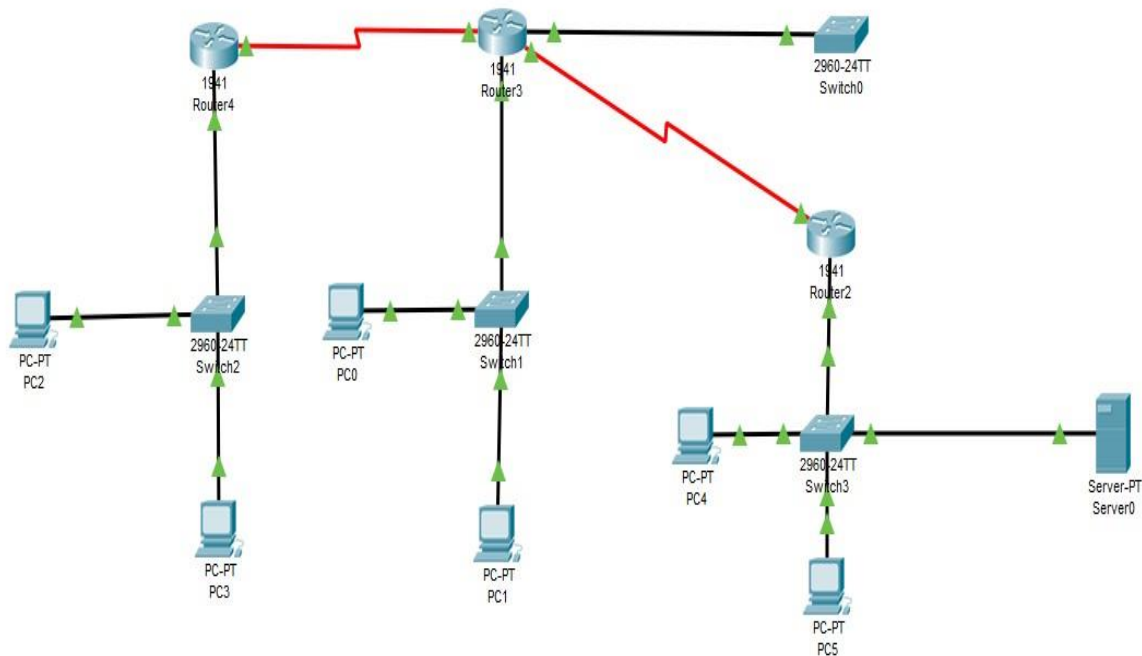

2. El DHCP deberá proporcionar solo direcciones a los hosts de Bucaramanga y Cundinamarca
3. El web server deberá tener NAT estático y el resto de los equipos de la topología emplearan NAT de sobrecarga (PAT).
4. El enrutamiento deberá tener autenticación.
5. Listas de control de acceso:
 - Los hosts de VLAN 20 en Cundinamarca no acceden a internet, solo a la red interna de Tunja.
 - Los hosts de VLAN 10 en Cundinamarca si acceden a internet y no a la red interna de Tunja.
 - Los hosts de VLAN 30 en Tunja solo acceden a servidores web y ftp de internet.
 - Los hosts de VLAN 20 en Tunja solo acceden a la VLAN 20 de Cundinamarca y VLAN 10 de Bucaramanga.
 - Los hosts de VLAN 30 de Bucaramanga acceden a internet y a cualquier equipo de VLAN 10.
 - Los hosts de VLAN 10 en Bucaramanga acceden a la red de Cundinamarca (VLAN 20) y Tunja (VLAN 20), no internet.
 - Los hosts de una VLAN no pueden acceder a los de otra VLAN en una ciudad.
 - Solo los hosts de las VLAN administrativas y de la VLAN de servidores tienen acceso a los routers e internet.
6. VLSM: utilizar la dirección 172.31.0.0 /18 para el direccionamiento.

Cisco Packet Tracer - C Users\Michael\Desktop\praxecto 2.pkt
 FM Ed Owns Ye ToOB Vensone Heb

Logical Physical x: 300, y: 32 [Root] 05:38:00

Port	Link	VLAN	IP Address	IPv6 Address	MAC Address
GigabitEthernet0/0	Up	--	<not set>	<not set>	00E0.BC22.5A01
GigabitEthernet0/0.10	Up	--	172.31.0.1/30	<not set>	00E0.BC22.5A01
GigabitEthernet0/0.30	Up	--	172.31.0.65/30	<not set>	00E0.BC22.5A01
GigabitEthernet0/1	Down	--	<not set>	<not set>	00E0.BC22.5A02
Serial0/0/0	Up	--	172.31.2.34/30	<not set>	<not set>
Serial0/0/1	Down	--	<not set>	<not set>	<not set>
Vlan1	Down	1	<not set>	<not set>	0030.A30E.7E83

Physical Location: Intercity, Home City, Corporate Office, Main Wiring Closet

Time: 01:46:54 Realtime Simulation

Copper Straight-Through

Ed* Otons Ve* TeoB lemons HeQ ?

Logical Physical x: 653, y: 24 [Root] 07:05:00

Port	Link	VLAN	IP Address	IPv6 Address	MAC Address
GigabitEthernet0/0	Down	--	<not set>	<not set>	00D0.BAC7.3301
GigabitEthernet0/1	Up	--	<not set>	<not set>	00D0.BAC7.3302
FastEthernet0/0/0	Up	--	<not set>	<not set>	00DA.419A.BC01
FastEthernet0/0/1	Up	1	--	<not set>	00DA.419A.BC02
FastEthernet0/0/2	Up	1	--	<not set>	00DA.419A.BC03
FastEthernet0/0/3	Up	1	--	<not set>	00DA.419A.BC04
Serial0/1/0	Up	--	172.31.2.38/30	<not set>	<not set>
Serial0/1/1	Up	--	172.31.2.33/30	<not set>	<not set>
Vlan1	Down	1	<not set>	<not set>	00D0.9755.AD65
Vlan20	Down	20	<not set>	<not set>	00D0.9755.AD01

Physical Location: Intercity, Home City, Corporate Office, Main Wiring Closet

Time: 01:49:48 Realtime Simulation

Copper Straight-Through



s 4n -

BOXU!âiE%i& @*OriSiE'iE

Realtime Simulation

Copper Straight-Through

Table of port status:

Port	Link	VLAN	IP Address	MAC Address
FastEthernet0/1	Up	--	--	0090.2BA9.0901
FastEthernet0/2	Up	10	--	0090.2BA9.0902
FastEthernet0/3	Up	30	--	0090.2BA9.0903
FastEthernet0/4	Down	1	--	0090.2BA9.0904
FastEthernet0/5	Down	1	--	0090.2BA9.0905
FastEthernet0/6	Down	1	--	0090.2BA9.0906
FastEthernet0/7	Down	1	--	0090.2BA9.0907
FastEthernet0/8	Down	1	--	0090.2BA9.0908
FastEthernet0/9	Down	1	--	0090.2BA9.0909
FastEthernet0/10	Down	1	--	0090.2BA9.090A
FastEthernet0/11	Down	1	--	0090.2BA9.090B
FastEthernet0/12	Down	1	--	0090.2BA9.090C
FastEthernet0/13	Down	1	--	0090.2BA9.090D
FastEthernet0/14	Down	1	--	0090.2BA9.090E
FastEthernet0/15	Down	1	--	0090.2BA9.090F
FastEthernet0/16	Down	1	--	0090.2BA9.0910
FastEthernet0/17	Down	1	--	0090.2BA9.0911
FastEthernet0/18	Down	1	--	0090.2BA9.0912
FastEthernet0/19	Down	1	--	0090.2BA9.0913
FastEthernet0/20	Down	1	--	0090.2BA9.0914
FastEthernet0/21	Down	1	--	0090.2BA9.0915
FastEthernet0/22	Down	1	--	0090.2BA9.0916
FastEthernet0/23	Down	1	--	0090.2BA9.0917
FastEthernet0/24	Down	1	--	0090.2BA9.0918
GigabitEthernet0/1	Down	1	--	0090.2BA9.0919
GigabitEthernet0/2	Down	1	--	0090.2BA9.091A
Vlan10	Down	1	<not set>	0030.A3C0.8B9C
Vlan30	Up	30	172.31.0.1/26	0030.A3C0.8B01
Vlan90	Up	90	172.31.0.65/30	0030.A3C0.8B02

Physical Location: Intercity, Home City, Corporate Office, Main Wiring Closet

Cisco Packet Tracer - C:\Users\Michael\Desktop\projecto-2.pkt

File Edit Options View Tools Extensions Help

Logical Physical x 205, y 210

Port	Link	VLAN	IP Address	MAC Address
FastEthernet0/1	Up	--	--	000C.CFED.3601
FastEthernet0/2	Up	20	--	000C.CFED.3602
FastEthernet0/3	Up	30	--	000C.CFED.3603
FastEthernet0/4	Down	1	--	000C.CFED.3604
FastEthernet0/5	Down	1	--	000C.CFED.3605
FastEthernet0/6	Down	1	--	000C.CFED.3606
FastEthernet0/7	Down	1	--	000C.CFED.3607
FastEthernet0/8	Down	1	--	000C.CFED.3608
FastEthernet0/9	Down	1	--	000C.CFED.3609
FastEthernet0/10	Down	1	--	000C.CFED.360A
FastEthernet0/11	Down	1	--	000C.CFED.360B
FastEthernet0/12	Down	1	--	000C.CFED.360C
FastEthernet0/13	Down	1	--	000C.CFED.360D
FastEthernet0/14	Down	1	--	000C.CFED.360E
FastEthernet0/15	Down	1	--	000C.CFED.360F
FastEthernet0/16	Down	1	--	000C.CFED.3610
FastEthernet0/17	Down	1	--	000C.CFED.3611
FastEthernet0/18	Down	1	--	000C.CFED.3612
FastEthernet0/19	Down	1	--	000C.CFED.3613
FastEthernet0/20	Down	1	--	000C.CFED.3614
FastEthernet0/21	Down	1	--	000C.CFED.3615
FastEthernet0/22	Down	1	--	000C.CFED.3616
FastEthernet0/23	Down	1	--	000C.CFED.3617
FastEthernet0/24	Down	1	--	000C.CFED.3618
GigabitEthernet0/1	Down	1	--	000C.CFED.3619
Vlan1	Down	--	<not set>	00E0.B0DD.7168
Vlan20	Up	20	172.31.0.129/26	00E0.B0DD.7101
Vlan30	Up	30	172.31.0.193/30	00E0.B0DD.7102

Physical Location: Intercity, Home City, Corporate Office, Main Wiring Closet

Time: 01:47:27

Realtime Simulation

Copper Straight-Through

Cisco Packet Tracer - C:\Users\Michael\Desktop\proy

File Edit Options View Tools Extensions Help

Logical Physical x 303, y 231

Port	Link	VLAN	IP Address	MAC Address
FastEthernet0/1	Up	1	--	00D0.BA58.CB01
FastEthernet0/2	Up	10	--	00D0.BA58.CB02
FastEthernet0/3	Up	20	--	00D0.BA58.CB03
FastEthernet0/4	Down	1	--	00D0.BA58.CB04
FastEthernet0/5	Down	1	--	00D0.BA58.CB05
FastEthernet0/6	Down	1	--	00D0.BA58.CB06
FastEthernet0/7	Down	1	--	00D0.BA58.CB07
FastEthernet0/8	Down	1	--	00D0.BA58.CB08
FastEthernet0/9	Down	1	--	00D0.BA58.CB09
FastEthernet0/10	Down	1	--	00D0.BA58.CB0A
FastEthernet0/11	Down	1	--	00D0.BA58.CB0B
FastEthernet0/12	Down	1	--	00D0.BA58.CB0C
FastEthernet0/13	Down	1	--	00D0.BA58.CB0D
FastEthernet0/14	Down	1	--	00D0.BA58.CB0E
FastEthernet0/15	Down	1	--	00D0.BA58.CB0F
FastEthernet0/16	Down	1	--	00D0.BA58.CB10
FastEthernet0/17	Down	1	--	00D0.BA58.CB11
FastEthernet0/18	Down	1	--	00D0.BA58.CB12
FastEthernet0/19	Down	1	--	00D0.BA58.CB13
FastEthernet0/20	Down	1	--	00D0.BA58.CB14
FastEthernet0/21	Down	1	--	00D0.BA58.CB15
FastEthernet0/22	Down	1	--	00D0.BA58.CB16
FastEthernet0/23	Down	1	--	00D0.BA58.CB17
FastEthernet0/24	Down	1	--	00D0.BA58.CB18
GigabitEthernet0/1	Up	--	--	00D0.BA58.CB19
GigabitEthernet0/2	Down	1	--	00D0.BA58.CB1A
Vlan1	Down	--	<not set>	0009.7C94.CB98
Vlan20	Up	20	172.31.1.65/30	0009.7C94.CB01

Physical Location: Intercity, Home City, Corporate Office, Main Wiring Closet

Time: 01:48:02

Realtime Simulation

Copper Straight-Through

CONCLUSIONES

Como resultado de la actividad desarrollada, se puede concluir que los conceptos básicos son fundamentales y cumplen un papel fundamental para el desarrollo y análisis de las actividades propuestas para el periodo académico.

La socialización de las actividades desarrolladas por cada integrante del grupo en el entorno de trabajo colaborativo nos permite conocer las opiniones y demás observaciones constructivas en pos al mejoramiento individual.

BIBLIOGRAFIA

Cisco Networking Academy Builds IT Skills & Education For Future Careers. (2019). Retrieved December 2019, from <https://www.netacad.com/es>