

DIPLOMADO DE PROFUNDIZACION CISCO CCNP
SOLUCIÓN DE DOS ESCENARIOS PRESENTES EN ENTORNOS
CORPORATIVOS BAJO EL USO DE TECNOLOGÍA CISCO

LUCERO MUÑOZ CAMPUZANO

UNIVERSIDAD NACIONAL ABIERTA Y A DISTANCIA - UNAD
ESCUELA DE CIENCIAS BASICAS, TECNOLOGIA E INGENIERIA - ECBTI
INGENIERIA DE TELECOMUNICACIONES
SANTIAGO DE CALI
2020

DIPLOMADO DE PROFUNDIZACION CISCO CCNP
SOLUCIÓN DE DOS ESCENARIOS PRESENTES EN ENTORNOS
CORPORATIVOS BAJO EL USO DE TECNOLOGÍA CISCO

LUCERO MUÑOZ CAMPUZANO

Diplomado de opción de grado presentado para optar por el
título de INGENIERA EN TELECOMUNICACIONES

DIRECTOR
GERARDO GRANADOS ACUÑA

UNIVERSIDAD NACIONAL ABIERTA Y A DISTANCIA - UNAD
ESCUELA DE CIENCIAS BASICAS, TECNOLOGIA E INGENIERIA - ECBTI
INGENIERIA DE TELECOMUNICACIONES
SANTIAGO DE CALI
2020

NOTA DE ACEPTACIÓN:

Presidente del Jurado

Jurado

Jurado

Santiago de Cali, 20 de noviembre de 2020

AGRADECIMIENTOS

El presente trabajo es gracias a las bendiciones recibidas cada día, que permitieron que hoy estuviera a un paso de llegar a la meta.

Dios como principal motor de mi vida, quien me dio esperanzas, fe y las fuerzas necesarias, para luchar día a día, en la realización de mis proyectos.

A mi tía Esperanza Muñoz, por ser ese apoyo constante, por darme esa energía en noches en vela, cuando mis fuerzas físicas decaían, siempre estaba para brindarme ese aire de confianza y ese soporte para continuar.

Un agradecimiento enorme, a aquellas personas que contribuyeron en este proyecto, tutores, compañeros, y demás allegados que jugaron un papel importante en el proceso, hoy ya estoy a unos pasos de la etapa final.

Gracias por acompañarme en la travesía de este sueño, que es el resultado del esfuerzo y dedicación de nuestros tutores, compañeros que con sus experiencias y enseñanzas enriquecieron nuestros conocimientos.

TABLA DE CONTENIDO

LISTA DE FIGURAS	7
GLOSARIO.....	10
RESUMEN.....	11
ABSTRACT	12
INTRODUCCIÓN.....	13
Escenario 1 Routing.....	14
Escenario laboratorio 1	14
Paso 1. Aplique las configuraciones iniciales y los protocolos de enrutamiento.....	15
Paso 2. Cree cuatro nuevas interfaces de Loopback en R1.....	20
Paso 3. Cree cuatro nuevas interfaces de Loopback en R5.....	21
Paso 4. Analice la tabla de enrutamiento de R3.....	22
Paso 5. Configure R3 para redistribuir las rutas EIGRP en.....	23
Paso 6. Verifique en R1 y R5 que las rutas del sistema autónomo opuesto existen..	24
Prueba Escenario 1 Routing	26
Escenario 2 Switching	28
Escenario laboratorio 2	28
Parte 1: Configurar la red de acuerdo con las especificaciones.	29
Parte 2: conectividad de red de prueba y las opciones configuradas.	76
CONCLUSIONES.....	87
BIBLIOGRAFÍA.....	88
ANEXOS	89
Script Routers Escenario 1	89
Router 1	89
Router 2	90
Router 3	90
Router 4	91

Router 5	91
Script Routers Escenario 2	93
Switch DLS1	93
Switch DLS2	97
Switch ALS1	101
Switch ALS2	103

LISTA DE FIGURAS

Figura 1. Escenario 1 Routing.....	14
Figura 2. Paso 1 en Router 1	15
Figura 3. Paso 1 en Router 2	16
Figura 4. Paso 1 en Router 3	17
Figura 5. Paso 1 en Router 4	18
Figura 6. Paso 1 en Router 5	19
Figura 7. Paso 2 en Router 1	20
Figura 8. Paso 3 en Router 5	21
Figura 9. Show ip route en R3	22
Figura 10. Redistribución Protocolos en R3	23
Figura 11. Show Ip Route en R1	24
Figura 12. Show Ip Route en R5	25
Figura 13. Prueba de Ping y Traza desde R1 a R5	26
Figura 14. Prueba de Ping y Traza desde R5 a R1	27
Figura 15. Escenario Switching.....	28
Figura 16. Interfaces apagadas en DLS1	29
Figura 17. Interfaces apagadas en DLS2	30
Figura 18. Interfaces apagadas en ALS1.....	31
Figura 19. Interfaces apagadas en ALS2.....	32
Figura 20. Interfaces apagadas en DLS1	33
Figura 21. Interfaces apagadas en DLS2	34
Figura 22. Interfaces apagadas en ALS1.....	34
Figura 23. Interfaces apagadas en ALS2.....	35
Figura 24. Etherchannel LACP Capa-3 en DLS1	36
Figura 25. Etherchannel LACP Capa-3 en DLS2	37
Figura 26. Configuración Etherchannel LACP Capa-3 en DLS1.....	38
Figura 27. Configuración Etherchannel LACP Capa-3 en DLS2.....	39
Figura 28. Enlace troncal Etherchannel 1 en DLS1	39
Figura 29. Enlace troncal Etherchannel Po2 en DLS2	40
Figura 30. Enlace troncal Etherchannel Po1 en ALS1	41
Figura 31. Enlace troncal Etherchannel Po1 en ALS2	41
Figura 32. Enlace troncal Etherchannel en DLS1	42
Figura 33. Etherchannel capa2 Po1 en DLS1.....	42
Figura 34. Enlace troncal Etherchannel Po2 en DLS2	43
Figura 35. Etherchannel capa2 Po2 en DLS2.....	43
Figura 36. Enlace troncal Etherchannel Po2 en ALS1 & Etherchannel capa2 Po2 en ALS1	44
Figura 37. Enlace troncal Etherchannel Po2 en ALS2 & Etherchannel capa2 Po2 en ALS2	44
Figura 38. Enlace troncal Etherchannel Po4 en DLS1	45
Figura 39. Enlace troncal Etherchannel Po3 en DLS2	46
Figura 40. Enlace troncal Etherchannel Po3 en ALS1	46
Figura 41. Enlace troncal Etherchannel Po4 en ALS2	47
Figura 42. Enlace troncal Etherchannel Po4 en DLS1	47

Figura 43. Etherchannel capa2 Po4 en DLS1.....	48
Figura 44. Enlace troncal Etherchannel Po3 en DLS2	48
Figura 45. Etherchannel capa2 Po3 en DLS2.....	49
Figura 46. Enlace troncal Etherchannel Po3 en ALS1	49
Figura 47. Etherchannel capa2 Po3 en ALS1.....	50
Figura 48. Enlace troncal Etherchannel Po4 en ALS2	50
Figura 49. Etherchannel capa2 Po4 en ALS2.....	51
Figura 50. VLAN 500 seteada en puertos troncales sw DLS1.....	52
Figura 51. VLAN 500 seteada en puertos troncales sw DLS2.....	53
Figura 52. VLAN 500 seteada en puertos troncales sw ALS1.....	54
Figura 53. VLAN 500 seteada en puertos troncales sw ALS2.....	54
Figura 54. Configuración VTP en DLS1	55
Figura 55. Configuración VTP modo cliente en ALS1	56
Figura 56. Configuración VTP modo cliente en ALS2	56
Figura 57. Estado configuración VTP en DLS1.....	57
Figura 58. Estado Configuración VTP en ALS1	57
Figura 59. Estado Configuración VTP en ALS2	57
Figura 60. Configuración VLANs en servidor principal.....	58
Figura 61. Estado configuración VLANs en servidor principal	59
Figura 62. Configuración VLANs 434 suspendida en DLS1.....	60
Figura 63. Estado VLANs 434 suspendida en DLS1	60
Figura 64. Configuración VLANs en DLS2.....	61
Figura 65. Estado configuración VLANs en DLS2.....	61
Figura 66. Configuración VLANs 434 suspendida en DLS2.....	62
Figura 67. Estado VLANs en DLS2.....	62
Figura 68. Configuración VLANs 567 en DLS2	63
Figura 69. Estado configuración VLANs en DLS2.....	63
Figura 70. Configuración Spanning tree root en DLS1	64
Figura 71. Estado Configuración STP DLS1.....	64
Figura 72. Estado Configuración STP DLS1.....	65
Figura 73. Estado Configuración STP DLS1.....	65
Figura 74. Estado Configuración STP DLS1.....	66
Figura 75. Configuración Spanning tree root en DLS2	66
Figura 76. Estado Configuración STP DLS2.....	67
Figura 77. Estado Configuración STP DLS2.....	67
Figura 78. Estado Configuración STP DLS2.....	68
Figura 79. Estado Configuración STP DLS2.....	69
Figura 80. Estado Configuración STP DLS2.....	69
Figura 81. Configuración VLANs permitidas en DLS1.....	70
Figura 82. Estado VLANs en DLS1.....	71
Figura 83. Configuración VLANs permitidas en DLS2.....	71
Figura 84. Estado VLANs en DLS2.....	72
Figura 85. Configuración VLANs permitidas en ALS1.....	73
Figura 86. Configuración VLANs permitidas en ALS2.....	73

Figura 87. Estado VLANs en ALS1.....	74
Figura 88. Estado VLANs en ALS2.....	74
Figura 89. Configuración puertos de acceso en DLS1.....	75
Figura 90. Configuración puertos de acceso en DLS2.....	75
Figura 91. Configuración puertos de acceso en ALS1.....	76
Figura 92. Configuración puertos de acceso en ALS2.....	76
Figura 93. VLAN creadas en DLS1.....	77
Figura 94. Verificación enlaces troncales y VLAN configurados en DLS1.....	77
Figura 95. VLAN creadas en DLS2.....	78
Figura 96. Verificación enlaces troncales y VLAN configurados en DLS2.....	78
Figura 97. VLAN creadas en ALS1.....	79
Figura 98. Verificación enlaces troncales y VLAN configurados en ALS1.....	79
Figura 99. VLAN creadas en ALS2.....	80
Figura 100. Verificación enlaces troncales y VLAN configurados en ALS2.....	80
Figura 101. Verificación configuración grupos etherchannel en DLS1.....	81
Figura 102. Verificación configuración grupos etherchannel en ALS1.....	81
Figura 103. Verificación configuración grupos etherchannel en DLS1.....	82
Figura 104. Verificación configuración grupos etherchannel en ALS1.....	82
Figura 105. Verificación configuración STP VLAN 500 en DLS1.....	83
Figura 106. Verificación configuración STP VLAN 12, 234 en DLS1.....	83
Figura 107. Verificación configuración STP VLAN 1111 en DLS1.....	84
Figura 108. Verificación configuración STP VLAN 123, 1010 en DLS1.....	84
Figura 109. Verificación configuración STP VLAN 500, 12 en DLS2.....	85
Figura 110. Verificación configuración STP VLAN 234, 1111 en DLS2.....	85
Figura 111. Verificación configuración STP VLAN 123, 1010 en DLS2.....	86
Figura 112. Verificación configuración STP VLAN 3456 en DLS2.....	86

GLOSARIO

CISCO: Cisco es el nombre de una compañía estadounidense dedicada al desarrollo de sistemas de comunicaciones por conmutación de paquetes, protocolos y más. Cisco se ha dedicado a lo largo de su trayectoria a implementar soluciones en dispositivos enrutadores, conmutadores, zonas inalámbricas, dispositivos ópticos, entre otros.

CCNP: Es una de las certificaciones que ofrece Cisco System, para entrenar a personal que desee conocer la tecnología actual y la forma de configurarlo de la mejor manera, ajustando al requerimiento particular de cada red cliente y ser capaz de resolver cualquier inconveniente que se presente.

Packet Tracert: Es una plataforma simuladora de ambientes de implementación de redes. Se encarga de ofrecer la oportunidad de crear una red, configurar dispositivos, implementar protocolos de enrutamiento y vivir la experiencia de dar marcha a una solución en ambiente práctico. Este software es de gran utilidad para quienes se están entrenando y no cuentan con un laboratorio real.

Networking: comúnmente se le conoce a la red de trabajo que cuenta con dos o más dispositivos de red que ofrecen servicios a clientes y a su vez reciben de otra red externa. Se trata básicamente de enfocar el tráfico de información por redes de telecomunicaciones que requieren tener un orden y estructura para su funcionamiento adecuado.

Switching: Switching se le llama al manejo y soporte en dispositivos de conmutación, que en ocasiones contienen funciones de enrutamiento pero que esencialmente son multiplexores para conexión de varios dispositivos hacia un solo concentrador para tratamiento en uso del enlace.

Direccionamiento IP: El direccionamiento IP es una identificación que se entrega a los terminales o host cliente de los servicios de red. IP se rige bajo protocolo de internet, se compone de dos versiones como son la IP versión 4, que cuenta con 4 octetos decimales con límite al número 255. La versión 6 de IP, se trata del aumento de la cantidad de octetos a 8, bajo número en sistema hexadecimal, su número máximo en cada octeto es el número FFFF.

Protocolos de enrutamiento: Los protocolos son una serie de pasos ordenados que se deben cumplir en un orden específico, no se pueden cambiar. Dichos pasos tratan de establecer las rutas de comunicación de acuerdo con el protocolo elegido que puede ser, enviar información por el camino más corto, o por el que esté disponible sin importar la cantidad de dispositivos en medio que deba atravesar.

RESUMEN

La intención con el presente trabajo práctico es demostrar las habilidades para enfrentar escenarios con requerimientos particulares definidos, de esa manera enfocar los esfuerzos y conocimientos para dar solución a lo planteado. Adicionalmente, se espera que con la realización de la presente prueba de habilidades en tecnología Cisco, se pueda realizar adecuadamente los pasos necesarios para cumplir con las expectativas del curso y las personales como futuros profesionales.

La prueba de habilidades cuenta con el escenario de enrutamiento, que se basa en 5 enrutadores interconectados por enlaces seriales, se forma un área de enrutamiento bajo protocolo OSPF en 3 enrutadores el 1, 2 y 3, como área 5, los siguientes equipos son los enrutadores 4 y 5 que se rigen bajo protocolo EIGRP con AS 15.

La intención de este escenario es tener conectividad lógica entre el enrutador 1 (inicial) y el enrutador 5(final).

La prueba de habilidades se realiza para dar cumplimiento al diplomado de profundización en Cisco CCNP de la Unad.

En cuanto al escenario 2, se presenta una solicitud para la formalización de una topología presentada, la cual debe ser configurada para su debida administración. Se compone de cuatro conmutadores o switch, interconectados de tal manera que se establezcan enlaces troncales y complementarios para garantizar un flujo de información constante con alta disponibilidad y redundancia. Dichos enlaces tendrán protocolos de conectividad como LACP y PAgP sobre sus etherchannel.

También se deben agregar Vlans para segmentar las áreas de red propuestas para fines particulares, esto para no combinar los tráficos y en escenario real, permitir fraccionar los fallos de red.

Palabras clave: Unad, CCNP, EIGRP, OSPF, Enrutador, Protocolos, Diplomado.

ABSTRACT

The intention with this practical work is to demonstrate the skills in real scenarios with defined particular requirements, in this way focus the efforts and knowledge to solve the problem. Additionally, it is expected that with the completion of this Cisco technology skills test, the necessary steps to meet the expectations of the course and personal expectations as future professionals can be adequately carried out.

The skills test has the routing scenario, which is based on 5 routers interconnected by serial links, a routing area is formed under the OSPF protocol in 3 routers on 1, 2 and 3, as area 5, the following equipment is the routers 4 and 5 operating under the EIGRP protocol with AS 15.

The objective of this scenario is to have logical connectivity between router 1 (initial) and router 5 (final).

The skills test is carried out to comply with the in-depth diploma in Cisco CCNP of the Unad.

About of scenario 2, a request is presented for the formalization of a presented topology, which must be configured for its own administration. It is made up of four switches, interconnected in such a way that backbones and complementary links are established to guarantee a constant flow of information with high availability and redundancy. These links will have connectivity protocols such as LACP and PAgP on their etherchannel.

Vlans must also be added to segment the network areas proposed for particular purposes, this in order not to combine the traffics and in a real scenario, allow network failures to be divided.

Keywords: Unad, CCNP, EIGRP, OSPF, Router, Protocols, Diploma.

INTRODUCCIÓN

La universidad Nacional Abierta y a Distancia, Unad, ha permitido tener como opción de grado, el curso de aprobación del diplomado de profundización en CCNP Cisco, con el fin de cumplir los requisitos académicos y legales para otorgamiento de título profesional. Es así como se presenta en este informe, dos escenarios de requisito establecidos para desarrollar la solución de enrutamiento.

Lo que vamos a observar en el primer escenario es la cadena de enrutadores que no presentan configuración alguna y que debemos aprovisionar para tener el resultado final esperado que es tener conectividad entre nuestras loopback de nuestro enrutador inicial R1 y las interfaces loopback del enrutador final R5.

Se demostrará mediante imágenes y resumen de las acciones realizadas para llegar a cumplir el objetivo.

Seguido del escenario de enrutamiento, se tiene previsto la configuración de un segundo escenario donde se incluyen cuatro switch de los cuales van a ser tratados para un fin en especial.

En este escenario se establecerán enlaces troncales bajo protocolos como LACP y PAgP, etherchannel. Se agregaron algunas vlan que nos permiten segmentar los grupos de trabajo necesarios, indicando sus respectivos nombres y descripciones para luego ser evidenciados en el funcionamiento de este.

Escenario 1 Routing

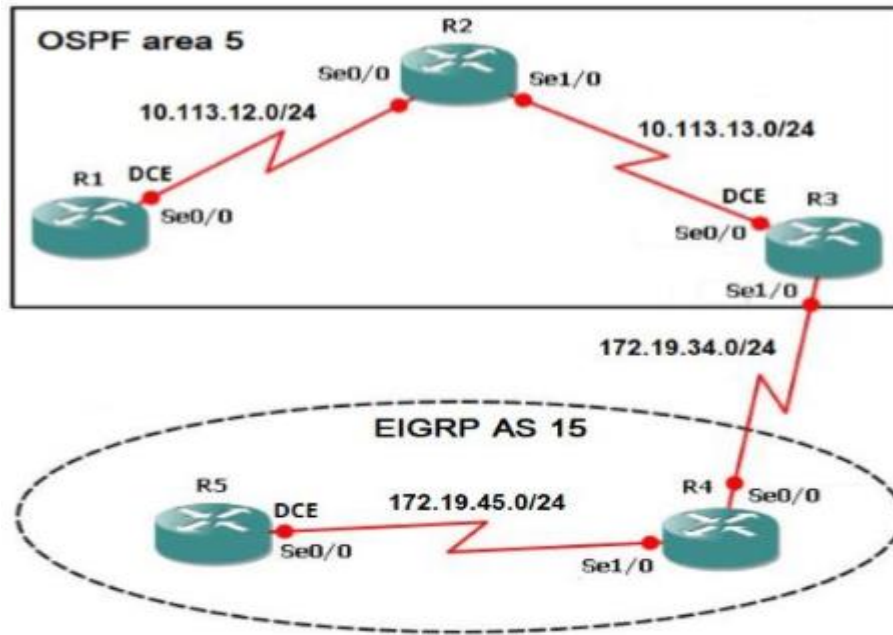

Escenario laboratorio 1

El siguiente grafico es la propuesta en Packet Tracer de acuerdo con lo solicitado.

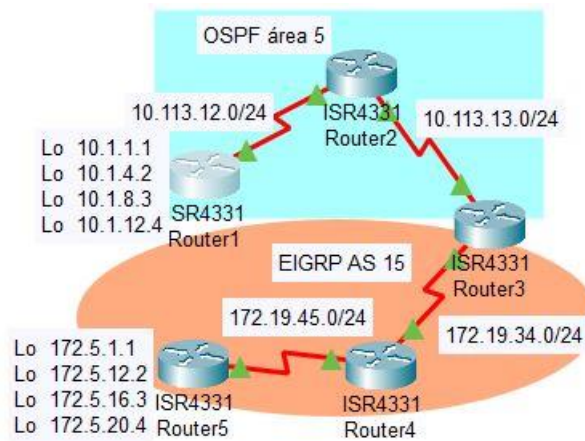

LUCERO MUÑOZ - CCNP - UNAD 2020

Figura 1. Escenario 1 Routing

Paso 1. Aplique las configuraciones iniciales y los protocolos de enrutamiento para los routers R1, R2, R3, R4 y R5 según el diagrama. No asigne passwords en los routers. Configurar las interfaces con las direcciones que se muestran en la topología de red.

Aunque en las descripciones de configuración no se contempla mayor detalle, solo configurar interfaces, lo que realizamos adicional es adicionar un Hostname para identificar cada router.

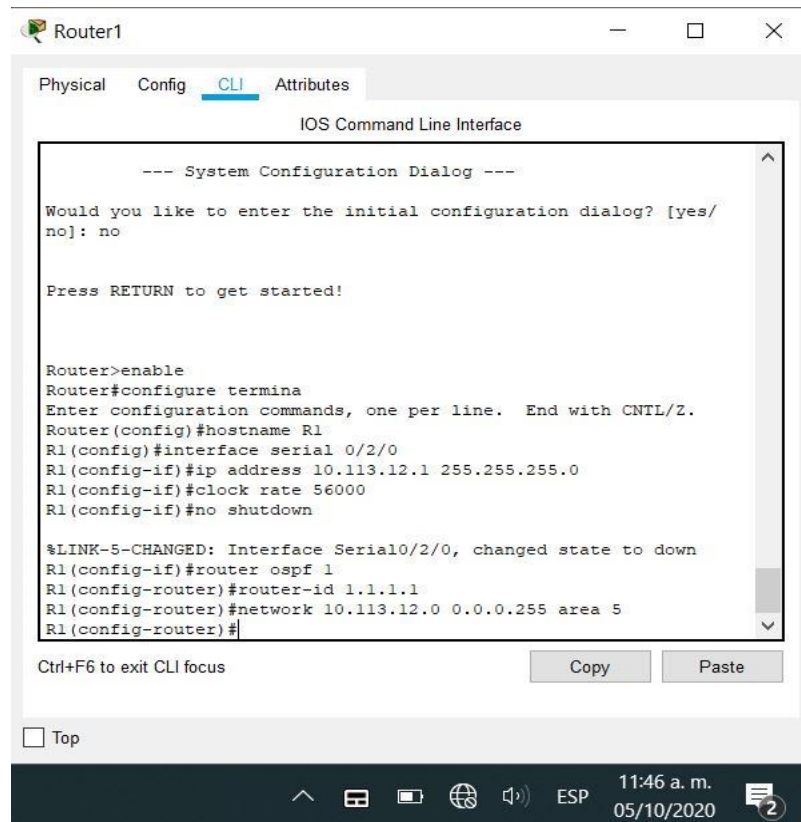

```
Router1
Physical Config CLI Attributes
IOS Command Line Interface

--- System Configuration Dialog ---
Would you like to enter the initial configuration dialog? [yes/no]: no
Press RETURN to get started!

Router>enable
Router#configure termina
Enter configuration commands, one per line. End with CNTL/Z.
Router(config)#hostname R1
R1(config)#interface serial 0/2/0
R1(config-if)#ip address 10.113.12.1 255.255.255.0
R1(config-if)#clock rate 56000
R1(config-if)#no shutdown

%LINK-5-CHANGED: Interface Serial0/2/0, changed state to down
R1(config-if)#router ospf 1
R1(config-router)#router-id 1.1.1.1
R1(config-router)#network 10.113.12.0 0.0.0.255 area 5
R1(config-router)#
```

Figura 2. Paso 1 en Router 1

Se puede observar que el primer router se configura el hostname como R1, en su enlace serial se configura la IP correspondiente, la máscara de red es /24 por lo cual es 255.255.255.0, se anexa un clock rate ya que esta interface será la DCE. Se puede observar que el router en la propuesta, el router 1 se encuentra en el proceso OSPF con área 5. El proceso OSPF lo llamamos 1 con un ID 1.1.1.1 anexamos la dirección de red con la wildcard respectiva.

```
Router2
Physical Config CLI Attributes
IOS Command Line Interface
Router#conf t
Enter configuration commands, one per line. End with CNTL/Z.
Router(config)#hostname R2
R2(config)#interface serial 0/2/0
R2(config-if)#ip address 10.113.12.2 255.255.255.0
R2(config-if)#no shutdown

R2(config-if)#
R2(config-if)#interface serial 0/2/1
R2(config-if)#ip address 10.113.13.1 255.255.255.0
R2(config-if)#no shutdown
%LINK-5-CHANGED: Interface Serial0/2/0, changed state to up

%LINK-5-CHANGED: Interface Serial0/2/1, changed state to down
R2(config-if)#
%LINEPROTO-5-UPDOWN: Line protocol on Interface Serial0/2/0,
changed state to up

R2(config-if)#router ospf 1
R2(config-router)#router-id 2.2.2.2
R2(config-router)#network 10.113.12.0 0.0.0.255 area 5
R2(config-router)#network 10.113.13.0 0.0.0.255 area 5
R2(config-router)#
00:09:21: %OSPF-5-ADJCHG: Process 1, Nbr 1.1.1.1 on Serial0/2/0

Ctrl+F6 to exit CLI focus Copy Paste
Top
```

Figura 3. Paso 1 en Router 2

En el router 2, se configuraron las interfaces seriales, no se anexa clock rate, el reloj configura en las interfaces DCE y este router no las debe tener, se indica un hostname como R2. Se configura también el protocolo OSPF en proceso 1 con las redes existentes en su configuración y las respectivas wildcard. Tener en cuenta que como es un router diferente se coloca un id diferente en este caso un 2.2.2.2.

```
Router3
Physical Config CLI Attributes
IOS Command Line Interface
Router#conf t
Enter configuration commands, one per line. End with CNTL/Z.
Router(config)#hostname R3
R3(config)#interface serial 0/2/0
R3(config-if)#ip address 10.113.13.2 255.255.255.0
R3(config-if)#clock rate 56000
R3(config-if)#no shutdown

R3(config-if)#
R3(config-if)#interface serial 0/2/1
R3(config-if)#ip address 172.19.34.1 255.255.255.0
R3(config-if)#no shutdown

%LINK-5-CHANGED: Interface Serial0/2/1, changed state to down
R3(config-if)#
R3(config-if)#router ospf 1
R3(config-router)#router-id 3.3.3.3
R3(config-router)#network 10.113.13.0 0.0.0.255 area 5
%LINK-5-CHANGED: Interface Serial0/2/0, changed state to up

%LINEPROTO-5-UPDOWN: Line protocol on Interface Serial0/2/0,
changed state to up

R3(config-router)#
00:02:10: %OSPF-5-ADJCHG: Process 1, Nbr 2.2.2.2 on Serial0/2/0
from LOADING to FULL, Loading Done

Ctrl+F6 to exit CLI focus
Copy Paste
Top
11:54 a.m.
05/10/2020
```

Figura 4. Paso 1 en Router 3

En el router 3, se configura de igual manera un hostname como R2, las interfaces seriales una con el clock rate para comunicación con R2, la interface serial que comunica hacia R4 no se especifica cuál de ellas sería el DCE por lo que no se configura en este equipo. El router también hace parte del protocolo OSPF 1, se anexan las redes correspondientes y sus respectivas wildcard.

```
Router4
Physical Config CLI Attributes
IOS Command Line Interface
Router#conf t
Enter configuration commands, one per line. End with CNTL/Z.
Router(config)#hostname R4
R4(config)#interface serial 0/2/0
R4(config-if)#ip address 172.19.34.2 255.255.255.0
R4(config-if)#clock rate 56000
R4(config-if)#no shutdown

R4(config-if)#
R4(config-if)#interface serial 0/2/1
R4(config-if)#ip address 172.19.45.1 255.255.255.0
R4(config-if)#no shutdown

%LINK-5-CHANGED: Interface Serial0/2/1, changed state to down
R4(config-if)#
R4(config-if)#router eigrp 15
R4(config-router)#network 172.19.45.0
%LINK-5-CHANGED: Interface Serial0/2/0, changed state to up

R4(config-router)#
%LINEPROTO-5-UPDOWN: Line protocol on Interface Serial0/2/0,
changed state to up

%LINK-5-CHANGED: Interface Serial0/2/1, changed state to up
%LINEPROTO-5-UPDOWN: Line protocol on Interface Serial0/2/1,
changed state to up

Ctrl+F6 to exit CLI focus
Copy Paste
Top
```

Figura 5. Paso 1 en Router 4

En el router 4, se configuran las interfaces de acuerdo con el diseño original, en la interface serial que comunica con R3 se configura clock rate dando acción de DCE, en la interface serial que comunica a R5 no se anexa reloj, no tiene interfaces Lan o Loopback. Se configura protocolo EIGRP con AS 15 y se agregan las dos redes que hacen parte de las interfaces seriales con sus respectivas wildcard y no es necesario indicar un ID de router.



Figura 6. Paso 1 en Router 5

En este router se configuró el hostname para identificar R5, se indica a una sola interface serial la IP correspondiente con el clock rate para identificarla como DCE, se configura proceso EIGRP 15 con la dirección de red correspondiente, podemos ver que inmediatamente se genera adyacencia.

Paso 2. Cree cuatro nuevas interfaces de Loopback en R1 utilizando la asignación de direcciones 10.1.0.0/22 y configure esas interfaces para participar en el área 5 de OSPF.

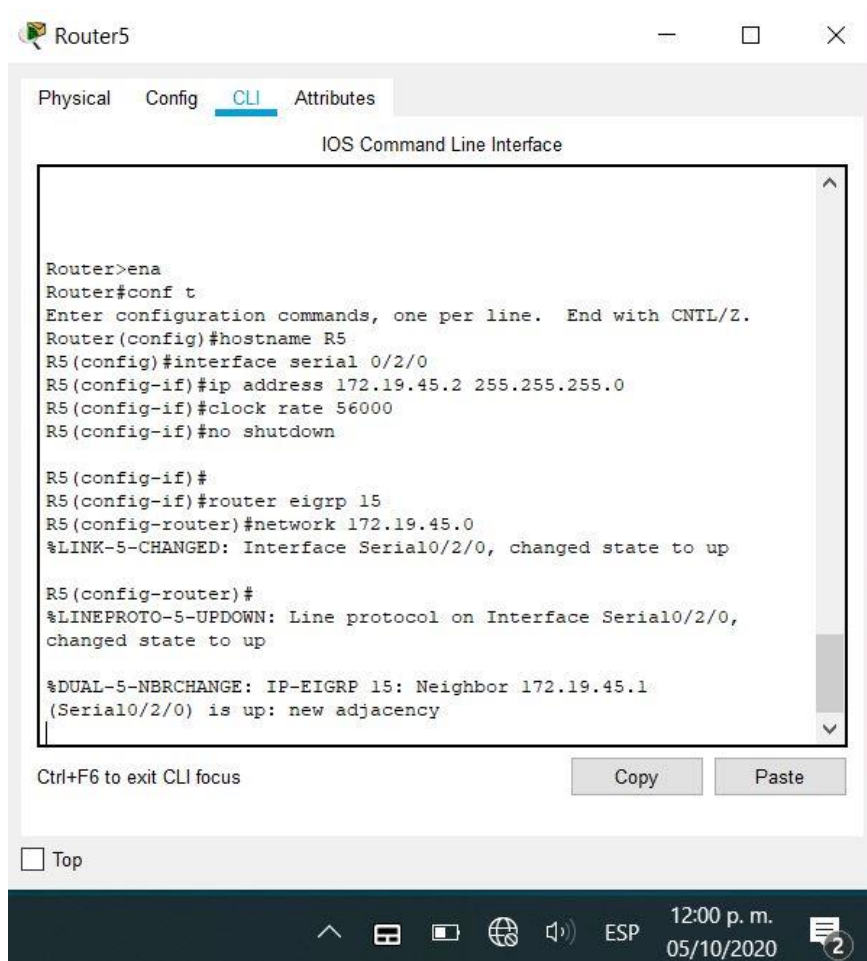
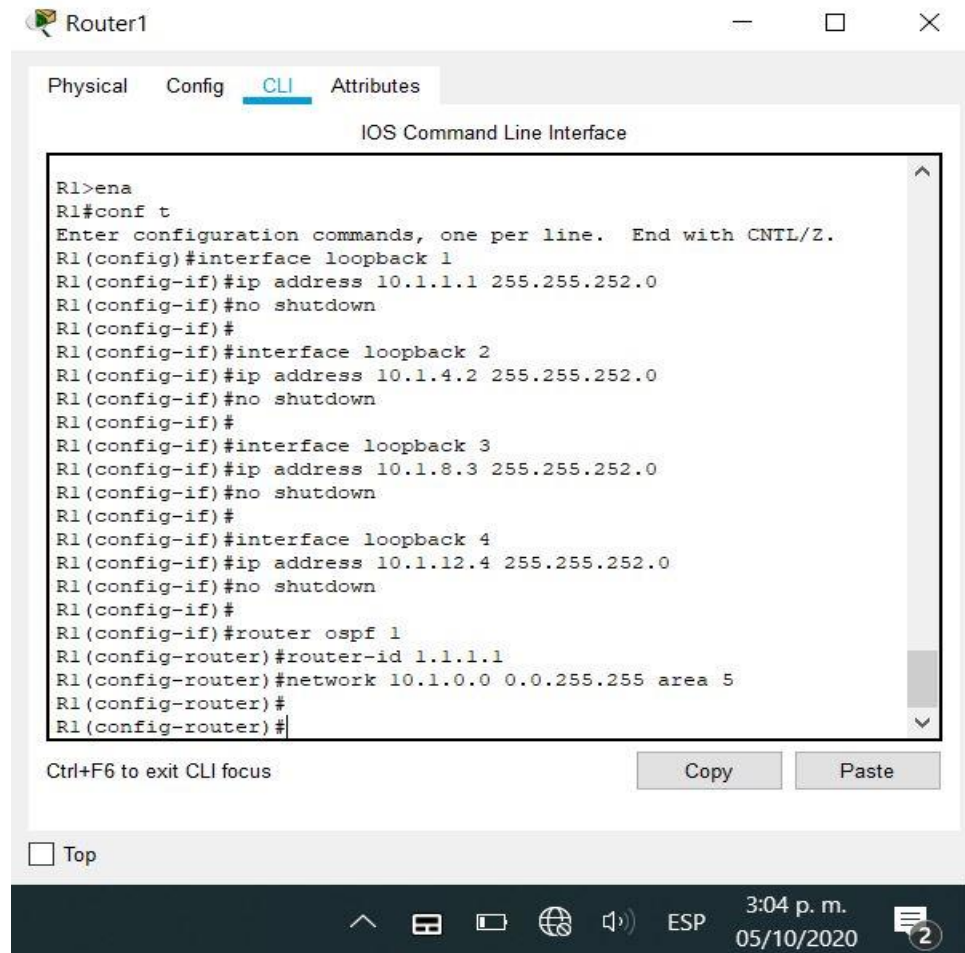

```
R1>ena
R1#conf t
Enter configuration commands, one per line. End with CNTL/Z.
R1(config)#interface loopback 1
R1(config-if)#ip address 10.1.1.1 255.255.252.0
R1(config-if)#no shutdown
R1(config-if)#
R1(config-if)#interface loopback 2
R1(config-if)#ip address 10.1.4.2 255.255.252.0
R1(config-if)#no shutdown
R1(config-if)#
R1(config-if)#interface loopback 3
R1(config-if)#ip address 10.1.8.3 255.255.252.0
R1(config-if)#no shutdown
R1(config-if)#
R1(config-if)#interface loopback 4
R1(config-if)#ip address 10.1.12.4 255.255.252.0
R1(config-if)#no shutdown
R1(config-if)#
R1(config-if)#router ospf 1
R1(config-router)#router-id 1.1.1.1
R1(config-router)#network 10.1.0.0 0.0.255.255 area 5
R1(config-router)#
R1(config-router)#
```

Ctrl+F6 to exit CLI focus

Copy Paste

Top

3:04 p. m. 05/10/2020

Figura 7. Paso 2 en Router 1

Para el paso 2 en el router R1, agregamos las interfaces Loopback de la misma manera como lo haríamos con una interface física. Indicamos la IP Address, y su respectiva mascara de subred. En este caso como se solicita una 10.1.0.0/22, a cada una de las loopback se asigna una ip de diferente rango para evitar solapamiento, además se agregan al proceso de enrutamiento OSPF área 5.

Paso 3. Cree cuatro nuevas interfaces de Loopback en R5 utilizando la asignación de direcciones 172.5.0.0/22 y configure esas interfaces para participar en el Sistema Autónomo EIGRP 15.

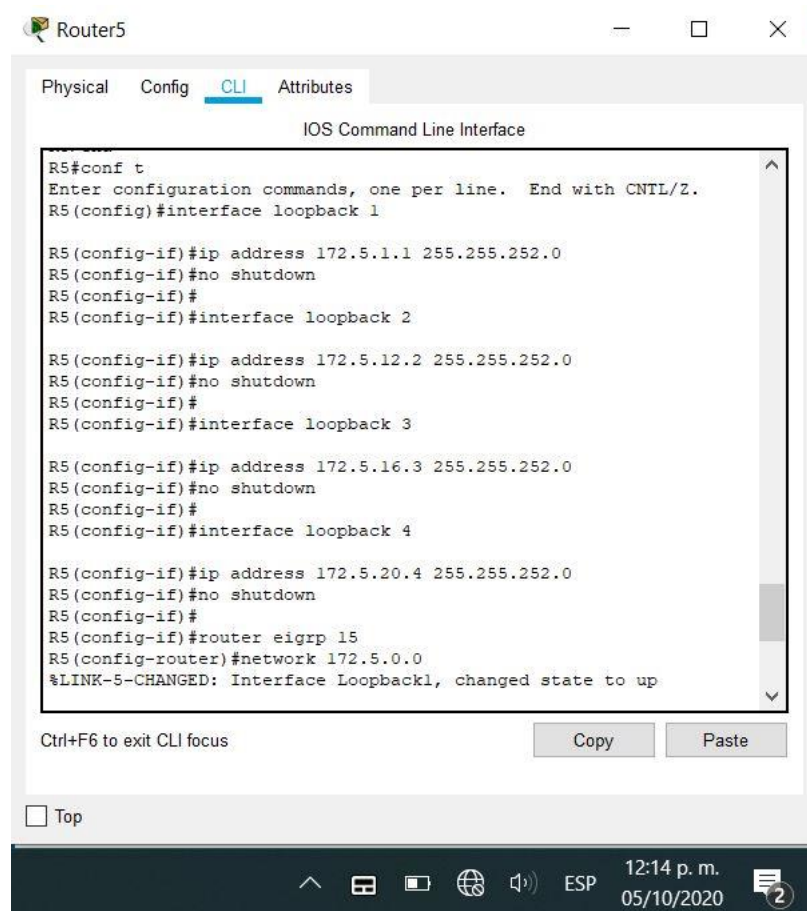

```
R5#conf t
Enter configuration commands, one per line. End with CNTL/Z.
R5(config)#interface loopback 1

R5(config-if)#ip address 172.5.1.1 255.255.252.0
R5(config-if)#no shutdown
R5(config-if)#
R5(config-if)#interface loopback 2

R5(config-if)#ip address 172.5.12.2 255.255.252.0
R5(config-if)#no shutdown
R5(config-if)#
R5(config-if)#interface loopback 3

R5(config-if)#ip address 172.5.16.3 255.255.252.0
R5(config-if)#no shutdown
R5(config-if)#
R5(config-if)#interface loopback 4

R5(config-if)#ip address 172.5.20.4 255.255.252.0
R5(config-if)#no shutdown
R5(config-if)#
R5(config-if)#router eigrp 15
R5(config-router)#network 172.5.0.0
%LINK-5-CHANGED: Interface Loopback1, changed state to up
```

Ctrl+F6 to exit CLI focus

Copy Paste

Top

12:14 p. m. 05/10/2020

Figura 8. Paso 3 en Router 5

En el router R5, de igual manera como se realizó en el R1, se agregan las interfaces Loopback, también con direcciones IP de diferentes rangos sobre la red 172.5.0.0/22 para evitar que se solapen y se agrega esa red al proceso EIGRP en curso para poder acceder a ellas más adelante, en EIGRP no necesitamos Wildcard.

Paso 4. Analice la tabla de enrutamiento de R3 y verifique que R3 está aprendiendo las nuevas interfaces de Loopback mediante el comando show ip route.

```
Router3
Physical Config CLI Attributes
IOS Command Line Interface
IS-IS inter area
* - candidate default, U - per-user static route, o - ODR
P - periodic downloaded static route
Gateway of last resort is not set
10.0.0.0/8 is variably subnetted, 7 subnets, 2 masks
O 10.1.1.1/32 [110/129] via 10.113.13.1, 00:03:55,
Serial0/2/0
O 10.1.4.2/32 [110/129] via 10.113.13.1, 00:03:55,
Serial0/2/0
O 10.1.8.3/32 [110/129] via 10.113.13.1, 00:03:55,
Serial0/2/0
O 10.1.12.4/32 [110/129] via 10.113.13.1, 00:03:55,
Serial0/2/0
O 10.113.12.0/24 [110/128] via 10.113.13.1, 00:04:05,
Serial0/2/0
C 10.113.13.0/24 is directly connected, Serial0/2/0
L 10.113.13.2/32 is directly connected, Serial0/2/0
172.5.0.0/22 is subnetted, 4 subnets
D 172.5.0.0/22 [90/2809856] via 172.19.34.2, 00:04:12,
Serial0/2/1
D 172.5.12.0/22 [90/2809856] via 172.19.34.2, 00:04:12,
Serial0/2/1
D 172.5.16.0/22 [90/2809856] via 172.19.34.2, 00:04:12,
Serial0/2/1
D 172.5.20.0/22 [90/2809856] via 172.19.34.2, 00:04:12,
Serial0/2/1
172.19.0.0/16 is variably subnetted, 3 subnets, 2 masks
C 172.19.34.0/24 is directly connected, Serial0/2/1
L 172.19.34.1/32 is directly connected, Serial0/2/1
D 172.19.45.0/24 [90/2681856] via 172.19.34.2, 00:04:12,
Serial0/2/1
R3#
```

Figura 9. Show ip route en R3

En este paso se requiere saber que redes son accesibles o se han actualizado en la tabla de enrutamiento del enrutador, por lo cual se aplica el código “Show ip route” para conocer que redes están aprendidas hasta el momento. Se observa que la red de las loopback en R1 con la letra O como OSPF y las loopback de R5 como D de EIGRP.

Paso 5. Configure R3 para redistribuir las rutas EIGRP en OSPF usando el costo de 50000 y luego redistribuya las rutas OSPF en EIGRP usando un ancho de banda T1 y 20,000 microsegundos de retardo.

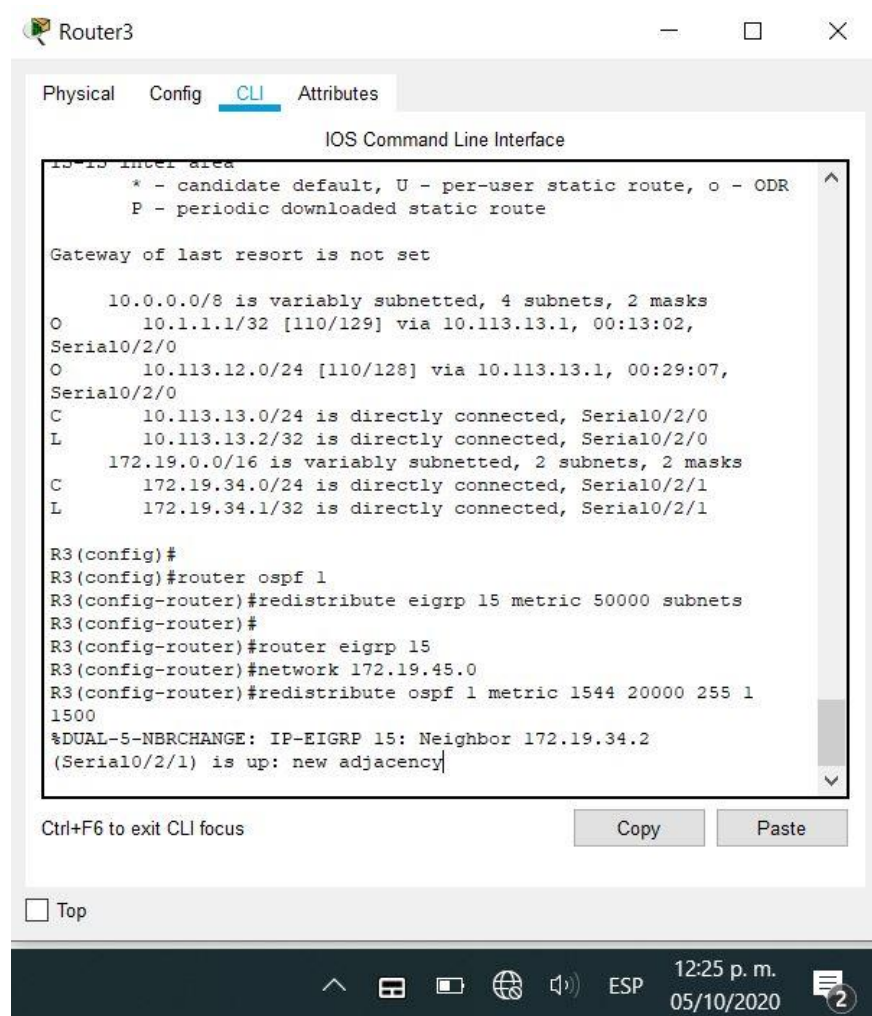

```
Router3
Physical Config CLI Attributes
IOS Command Line Interface
R3-15 inter area
* - candidate default, U - per-user static route, o - ODR
P - periodic downloaded static route

Gateway of last resort is not set

10.0.0.0/8 is variably subnetted, 4 subnets, 2 masks
O 10.1.1.1/32 [110/129] via 10.113.13.1, 00:13:02,
Serial0/2/0
O 10.113.12.0/24 [110/128] via 10.113.13.1, 00:29:07,
Serial0/2/0
C 10.113.13.0/24 is directly connected, Serial0/2/0
L 10.113.13.2/32 is directly connected, Serial0/2/0
172.19.0.0/16 is variably subnetted, 2 subnets, 2 masks
C 172.19.34.0/24 is directly connected, Serial0/2/1
L 172.19.34.1/32 is directly connected, Serial0/2/1

R3(config)#
R3(config)#router ospf 1
R3(config-router)#redistribute eigrp 15 metric 50000 subnets
R3(config-router)#
R3(config-router)#router eigrp 15
R3(config-router)#network 172.19.45.0
R3(config-router)#redistribute ospf 1 metric 1544 20000 255 1
1500
%DUAL-5-NBRCHANGE: IP-EIGRP 15: Neighbor 172.19.34.2
(Serial0/2/1) is up: new adjacency

Ctrl+F6 to exit CLI focus
Copy Paste
Top
```

Figura 10. Redistribución Protocolos en R3

Para realizar la redistribución, lo que se realizó en primera medida fue incorporar el R3 al proceso EIGRP sobre la interface que comunica hacia R4, con ello el equipo cuenta con los dos procesos junto con OSPF. Lo que se realiza es agregar la redistribución de EIGRP en OSPF, se agrega un redistribute eigrp con cantidad de saltos 15, métrica de 50.000. En EIGRP se redistribuye OSPF con métrica de 1544 un T1, retardo de 20.000.

Paso 6. Verifique en R1 y R5 que las rutas del sistema autónomo opuesto existen en su tabla de enrutamiento mediante el comando show ip route.

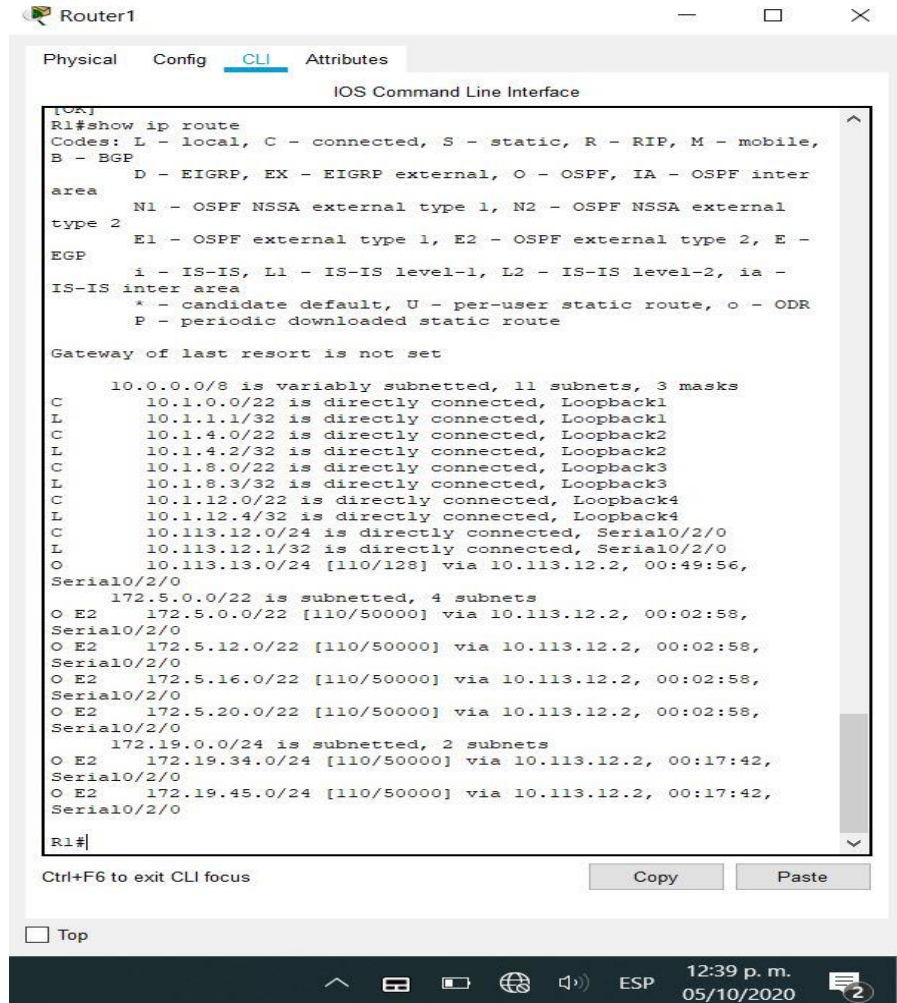

```
Router1
Physical Config CLI Attributes
IOS Command Line Interface
[OK]
R1#show ip route
Codes: L - local, C - connected, S - static, R - RIP, M - mobile,
B - BGP
D - EIGRP, EX - EIGRP external, O - OSPF, IA - OSPF inter
area
N1 - OSPF NSSA external type 1, N2 - OSPF NSSA external
type 2
E1 - OSPF external type 1, E2 - OSPF external type 2, E -
EGP
i - IS-IS, L1 - IS-IS level-1, L2 - IS-IS level-2, ia -
IS-IS inter area
* - candidate default, U - per-user static route, o - ODR
P - periodic downloaded static route

Gateway of last resort is not set

10.0.0.0/8 is variably subnetted, 11 subnets, 3 masks
C 10.1.0.0/22 is directly connected, Loopback1
L 10.1.1.1/32 is directly connected, Loopback1
C 10.1.4.0/22 is directly connected, Loopback2
L 10.1.4.2/32 is directly connected, Loopback2
C 10.1.8.0/22 is directly connected, Loopback3
L 10.1.8.3/32 is directly connected, Loopback3
C 10.1.12.0/22 is directly connected, Loopback4
L 10.1.12.4/32 is directly connected, Loopback4
C 10.113.12.0/24 is directly connected, Serial0/2/0
L 10.113.12.1/32 is directly connected, Serial0/2/0
O 10.113.13.0/24 [110/128] via 10.113.12.2, 00:49:56,
Serial0/2/0
172.5.0.0/22 is subnetted, 4 subnets
O E2 172.5.0.0/22 [110/50000] via 10.113.12.2, 00:02:58,
Serial0/2/0
O E2 172.5.12.0/22 [110/50000] via 10.113.12.2, 00:02:58,
Serial0/2/0
O E2 172.5.16.0/22 [110/50000] via 10.113.12.2, 00:02:58,
Serial0/2/0
O E2 172.5.20.0/22 [110/50000] via 10.113.12.2, 00:02:58,
Serial0/2/0
172.19.0.0/24 is subnetted, 2 subnets
O E2 172.19.34.0/24 [110/50000] via 10.113.12.2, 00:17:42,
Serial0/2/0
O E2 172.19.45.0/24 [110/50000] via 10.113.12.2, 00:17:42,
Serial0/2/0
R1#
```

Figura 11. Show Ip Route en R1

En el R1 se hace un Show ip Route para conocer las redes que se encuentran aprendidas, observamos las direcciones loopback en el equipo como L o local, que se encuentran directamente conectadas. También observamos las redes que conforman los enlaces seriales y en la parte baja vemos con la letra O y E2 que nos indican que esas redes las conocen de manera externa a OSPF, pertenecen al proceso EIGRP loopback en R5.

```
R5#sh ip route
Codes: L - local, C - connected, S - static, R - RIP, M - mobile,
B - BGP
       D - EIGRP, EX - EIGRP external, O - OSPF, IA - OSPF inter
area
       N1 - OSPF NSSA external type 1, N2 - OSPF NSSA external
type 2
       E1 - OSPF external type 1, E2 - OSPF external type 2, E -
EGP
       i - IS-IS, L1 - IS-IS level-1, L2 - IS-IS level-2, ia -
IS-IS inter area
       * - candidate default, U - per-user static route, o - ODR
       P - periodic downloaded static route

Gateway of last resort is not set

  10.0.0.0/8 is variably subnetted, 6 subnets, 2 masks
D EX   10.1.1.1/32 [170/7801856] via 172.19.45.1, 00:13:49,
Serial0/2/0
D EX   10.1.4.2/32 [170/7801856] via 172.19.45.1, 00:11:02,
Serial0/2/0
D EX   10.1.8.3/32 [170/7801856] via 172.19.45.1, 00:11:02,
Serial0/2/0
D EX   10.1.12.4/32 [170/7801856] via 172.19.45.1, 00:10:53,
Serial0/2/0
D EX   10.113.12.0/24 [170/7801856] via 172.19.45.1, 00:13:59,
Serial0/2/0
D EX   10.113.13.0/24 [170/7801856] via 172.19.45.1, 00:55:56,
Serial0/2/0
  172.5.0.0/16 is variably subnetted, 8 subnets, 2 masks
C       172.5.0.0/22 is directly connected, Loopback1
L       172.5.1.1/32 is directly connected, Loopback1
C       172.5.12.0/22 is directly connected, Loopback2
L       172.5.12.2/32 is directly connected, Loopback2
C       172.5.16.0/22 is directly connected, Loopback3
L       172.5.16.3/32 is directly connected, Loopback3
C       172.5.20.0/22 is directly connected, Loopback4
L       172.5.20.4/32 is directly connected, Loopback4
  172.19.0.0/16 is variably subnetted, 3 subnets, 2 masks
D       172.19.34.0/24 [90/2681856] via 172.19.45.1, 00:55:56,
Serial0/2/0
C       172.19.45.0/24 is directly connected, Serial0/2/0
L       172.19.45.2/32 is directly connected, Serial0/2/0

R5#
```

Figura 12. Show Ip Route en R5

En el router 5, aplicando el show ip route, podemos verificar en la parte superior, que vemos algunas direcciones iniciando con la letra D EX, dichas direcciones son las redes que se aprendieron externamente al proceso EIGRP, entre ellas están las loopback del R1 y los enlaces inmersos en el proceso. En la parte baja vemos las redes que están de manera local como los seriales y las loopback de R5.

Prueba Escenario 1 Routing

En este punto realizamos una prueba desde el enrutador 1 para verificar conectividad con IP loopback en R5. También se realiza una prueba de traza para verificar que se tiene acceso hacia otra de las IP loopback y que es exitoso.

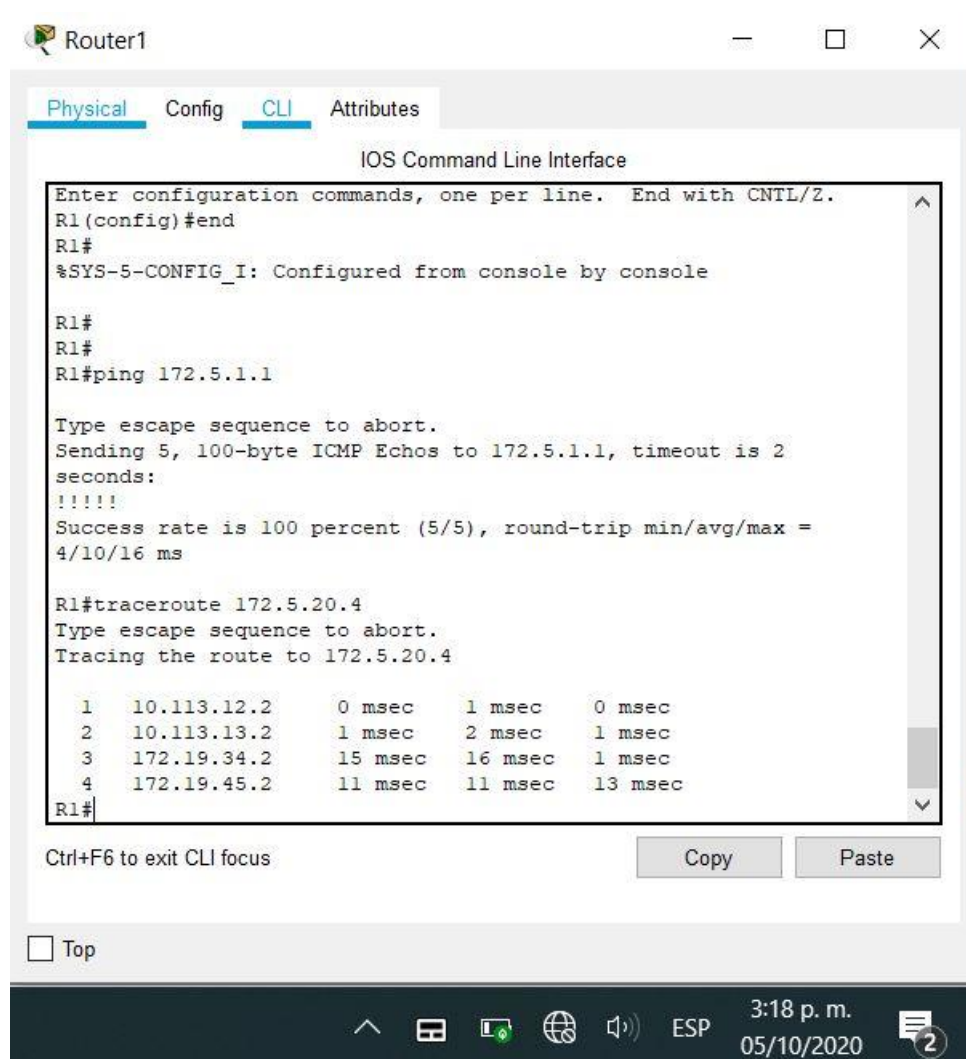

The screenshot shows the CLI of Router1 with the following text:

```
Enter configuration commands, one per line. End with CNTL/Z.
R1(config)#end
R1#
%SYS-5-CONFIG_I: Configured from console by console

R1#
R1#
R1#ping 172.5.1.1

Type escape sequence to abort.
Sending 5, 100-byte ICMP Echos to 172.5.1.1, timeout is 2
seconds:
!!!!
Success rate is 100 percent (5/5), round-trip min/avg/max =
4/10/16 ms

R1#traceroute 172.5.20.4
Type escape sequence to abort.
Tracing the route to 172.5.20.4

 1  10.113.12.2      0 msec    1 msec    0 msec
 2  10.113.13.2      1 msec    2 msec    1 msec
 3  172.19.34.2     15 msec   16 msec    1 msec
 4  172.19.45.2     11 msec   11 msec   13 msec

R1#
```

Below the terminal window, there are buttons for 'Copy' and 'Paste', and a 'Top' button. The system tray at the bottom shows the time as 3:18 p.m. on 05/10/2020.

Figura 13. Prueba de Ping y Traza desde R1 a R5

Nuevamente se realiza prueba de ping desde R5 hacia una IP loopback en R1 y una traza para verificar que se tiene llegada a otra IP loopback en el mismo R1 pasando por todas las interfaces seriales de distintos protocolos.

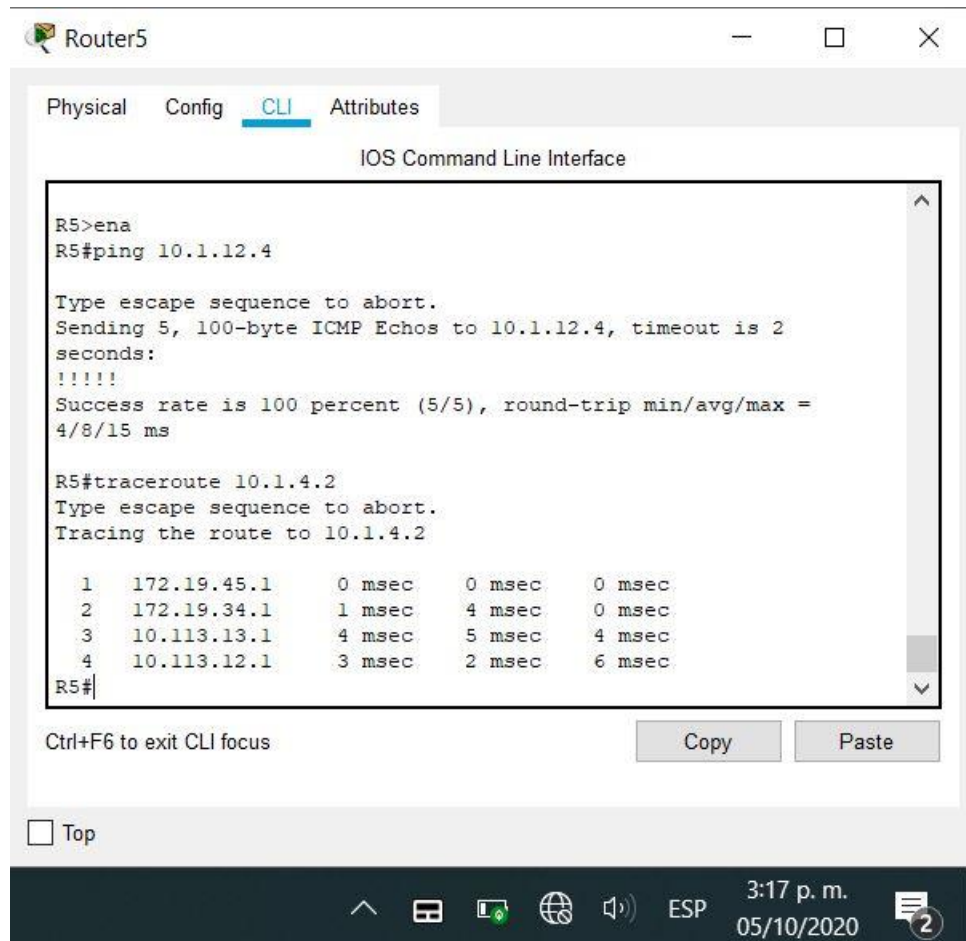

The screenshot shows the CLI of Router5. The user has entered the command `ping 10.1.12.4` and received a success rate of 100 percent (5/5) with a round-trip time of 4/8/15 ms. The user then entered the command `traceroute 10.1.4.2` and received the following output:

```
R5#traceroute 10.1.4.2
Type escape sequence to abort.
Tracing the route to 10.1.4.2

 0  172.19.45.1      0 msec  0 msec  0 msec
 1  172.19.34.1      1 msec  4 msec  0 msec
 2  10.113.13.1     4 msec  5 msec  4 msec
 3  10.113.12.1     3 msec  2 msec  6 msec
```

The output shows a path of four hops: 172.19.45.1, 172.19.34.1, 10.113.13.1, and 10.113.12.1. The round-trip times for each hop are 0 msec, 4 msec, 5 msec, and 2 msec respectively. The final destination is 10.1.4.2.

Figura 14. Prueba de Ping y Traza desde R5 a R1

Escenario 2 Switching

Una empresa de comunicaciones presenta una estructura Core acorde a la topología de red, en donde el estudiante será el administrador de la red, el cual deberá configurar e interconectar entre sí cada uno de los dispositivos que forman parte del escenario, acorde con los lineamientos establecidos para el direccionamiento IP, etherchannels, VLANs y demás aspectos que forman parte del escenario propuesto.

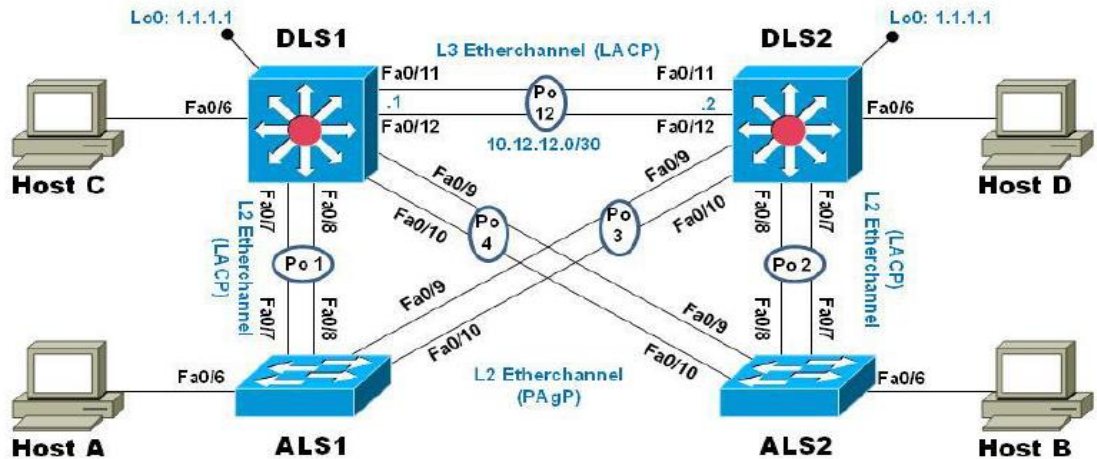

Escenario laboratorio 2



Figura 15. Escenario Switching

Parte 1: Configurar la red de acuerdo con las especificaciones.

- Apagar todas las interfaces en cada switch. Asignar un nombre a cada switch acorde con el escenario establecido.

En este punto realizamos el apagado de las interfaces en su totalidad, ya que los SW por defecto los tiene habilitados, este proceso se realiza en los 4 SW presentes en el escenario. Por otro lado, el hostname, no se aplica comando, dado que desde el escenario en gns3, se realiza cambio de nombre de cada switch.

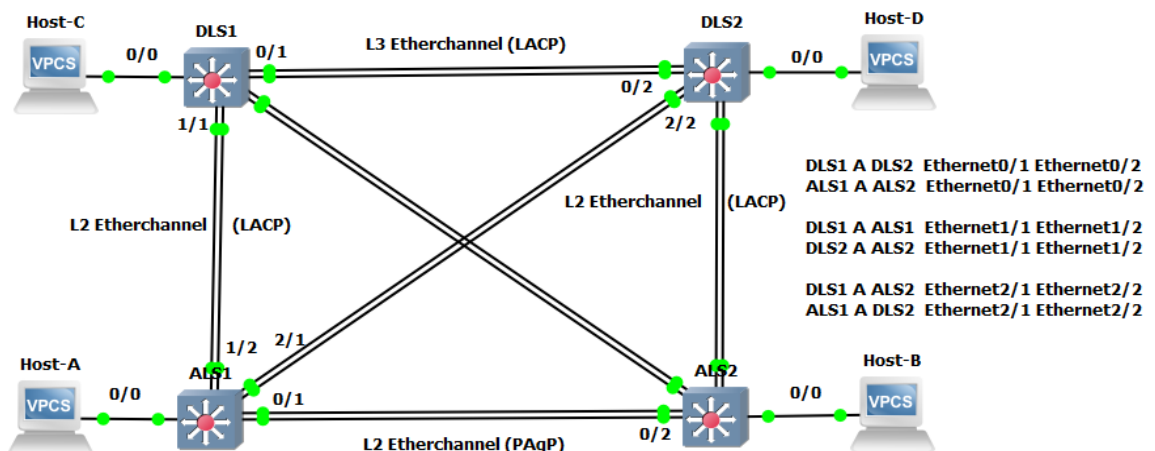
Switch DLS1

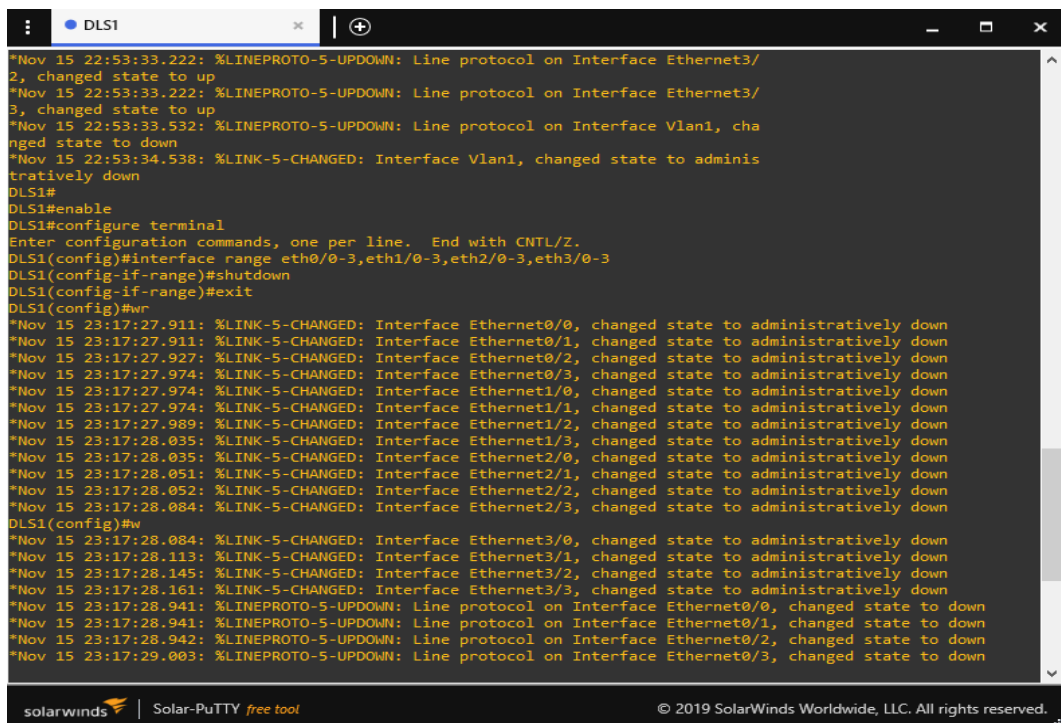

```
DLS1
*Nov 15 22:53:33.222: %LINEPROTO-5-UPDOWN: Line protocol on Interface Ethernet3/
2, changed state to up
*Nov 15 22:53:33.222: %LINEPROTO-5-UPDOWN: Line protocol on Interface Ethernet3/
3, changed state to up
*Nov 15 22:53:33.532: %LINEPROTO-5-UPDOWN: Line protocol on Interface Vlan1, cha
nged state to down
*Nov 15 22:53:34.538: %LINK-5-CHANGED: Interface Vlan1, changed state to adminis
tratively down
DLS1#
DLS1#enable
DLS1#configure terminal
Enter configuration commands, one per line. End with CNTL/Z.
DLS1(config)#interface range eth0/0-3,eth1/0-3,eth2/0-3,eth3/0-3
DLS1(config-if-range)#shutdown
DLS1(config-if-range)#exit
DLS1(config)#wr
*Nov 15 23:17:27.911: %LINK-5-CHANGED: Interface Ethernet0/0, changed state to administratively down
*Nov 15 23:17:27.911: %LINK-5-CHANGED: Interface Ethernet0/1, changed state to administratively down
*Nov 15 23:17:27.927: %LINK-5-CHANGED: Interface Ethernet0/2, changed state to administratively down
*Nov 15 23:17:27.974: %LINK-5-CHANGED: Interface Ethernet0/3, changed state to administratively down
*Nov 15 23:17:27.974: %LINK-5-CHANGED: Interface Ethernet1/0, changed state to administratively down
*Nov 15 23:17:27.974: %LINK-5-CHANGED: Interface Ethernet1/1, changed state to administratively down
*Nov 15 23:17:27.989: %LINK-5-CHANGED: Interface Ethernet1/2, changed state to administratively down
*Nov 15 23:17:28.035: %LINK-5-CHANGED: Interface Ethernet1/3, changed state to administratively down
*Nov 15 23:17:28.035: %LINK-5-CHANGED: Interface Ethernet2/0, changed state to administratively down
*Nov 15 23:17:28.051: %LINK-5-CHANGED: Interface Ethernet2/1, changed state to administratively down
*Nov 15 23:17:28.052: %LINK-5-CHANGED: Interface Ethernet2/2, changed state to administratively down
*Nov 15 23:17:28.084: %LINK-5-CHANGED: Interface Ethernet2/3, changed state to administratively down
DLS1(config)#w
*Nov 15 23:17:28.084: %LINK-5-CHANGED: Interface Ethernet3/0, changed state to administratively down
*Nov 15 23:17:28.113: %LINK-5-CHANGED: Interface Ethernet3/1, changed state to administratively down
*Nov 15 23:17:28.145: %LINK-5-CHANGED: Interface Ethernet3/2, changed state to administratively down
*Nov 15 23:17:28.161: %LINK-5-CHANGED: Interface Ethernet3/3, changed state to administratively down
*Nov 15 23:17:28.941: %LINEPROTO-5-UPDOWN: Line protocol on Interface Ethernet0/0, changed state to down
*Nov 15 23:17:28.941: %LINEPROTO-5-UPDOWN: Line protocol on Interface Ethernet0/1, changed state to down
*Nov 15 23:17:28.942: %LINEPROTO-5-UPDOWN: Line protocol on Interface Ethernet0/2, changed state to down
*Nov 15 23:17:29.003: %LINEPROTO-5-UPDOWN: Line protocol on Interface Ethernet0/3, changed state to down
```

Figura 16. Interfaces apagadas en DLS1

Comandos

```
enable
configure terminal
interface range eth0/0-3,eth1/0-3,eth2/0-3,eth3/0-3
shutdown
end
wr
```

Switch DLS2

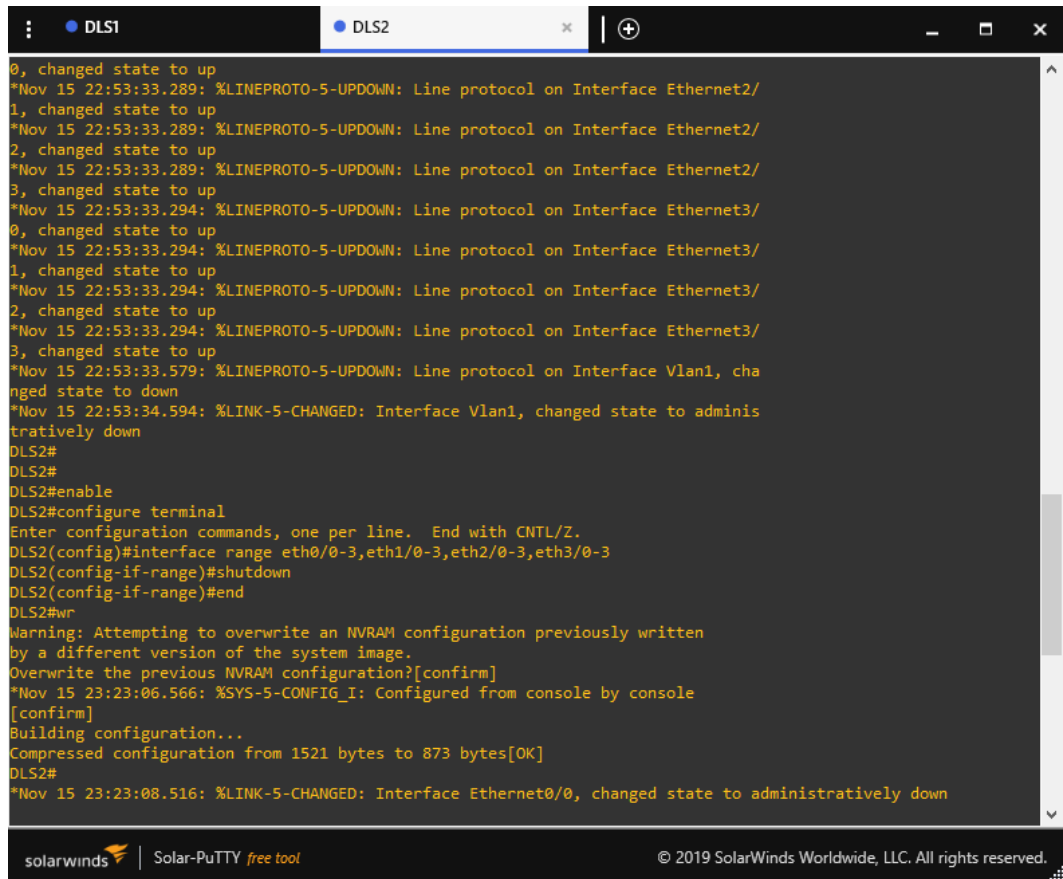

```
DLS1
DLS2
0, changed state to up
*Nov 15 22:53:33.289: %LINEPROTO-5-UPDOWN: Line protocol on Interface Ethernet2/
1, changed state to up
*Nov 15 22:53:33.289: %LINEPROTO-5-UPDOWN: Line protocol on Interface Ethernet2/
2, changed state to up
*Nov 15 22:53:33.289: %LINEPROTO-5-UPDOWN: Line protocol on Interface Ethernet2/
3, changed state to up
*Nov 15 22:53:33.294: %LINEPROTO-5-UPDOWN: Line protocol on Interface Ethernet3/
0, changed state to up
*Nov 15 22:53:33.294: %LINEPROTO-5-UPDOWN: Line protocol on Interface Ethernet3/
1, changed state to up
*Nov 15 22:53:33.294: %LINEPROTO-5-UPDOWN: Line protocol on Interface Ethernet3/
2, changed state to up
*Nov 15 22:53:33.294: %LINEPROTO-5-UPDOWN: Line protocol on Interface Ethernet3/
3, changed state to up
*Nov 15 22:53:33.579: %LINEPROTO-5-UPDOWN: Line protocol on Interface Vlan1, cha
nged state to down
*Nov 15 22:53:34.594: %LINK-5-CHANGED: Interface Vlan1, changed state to adminis
tratively down
DLS2#
DLS2#
DLS2#enable
DLS2#configure terminal
Enter configuration commands, one per line. End with CNTL/Z.
DLS2(config)#interface range eth0/0-3,eth1/0-3,eth2/0-3,eth3/0-3
DLS2(config-if-range)#shutdown
DLS2(config-if-range)#end
DLS2#wr
Warning: Attempting to overwrite an NVRAM configuration previously written
by a different version of the system image.
Overwrite the previous NVRAM configuration?[confirm]
*Nov 15 23:23:06.566: %SYS-5-CONFIG_I: Configured from console by console
[confirm]
Building configuration...
Compressed configuration from 1521 bytes to 873 bytes[OK]
DLS2#
*Nov 15 23:23:08.516: %LINK-5-CHANGED: Interface Ethernet0/0, changed state to administratively down
```

Figura 17. Interfaces apagadas en DLS2

Comandos

```
enable
configure terminal
interface range eth0/0-3,eth1/0-3,eth2/0-3,eth3/0-3
shutdown
end
wr
```

Switch ALS1

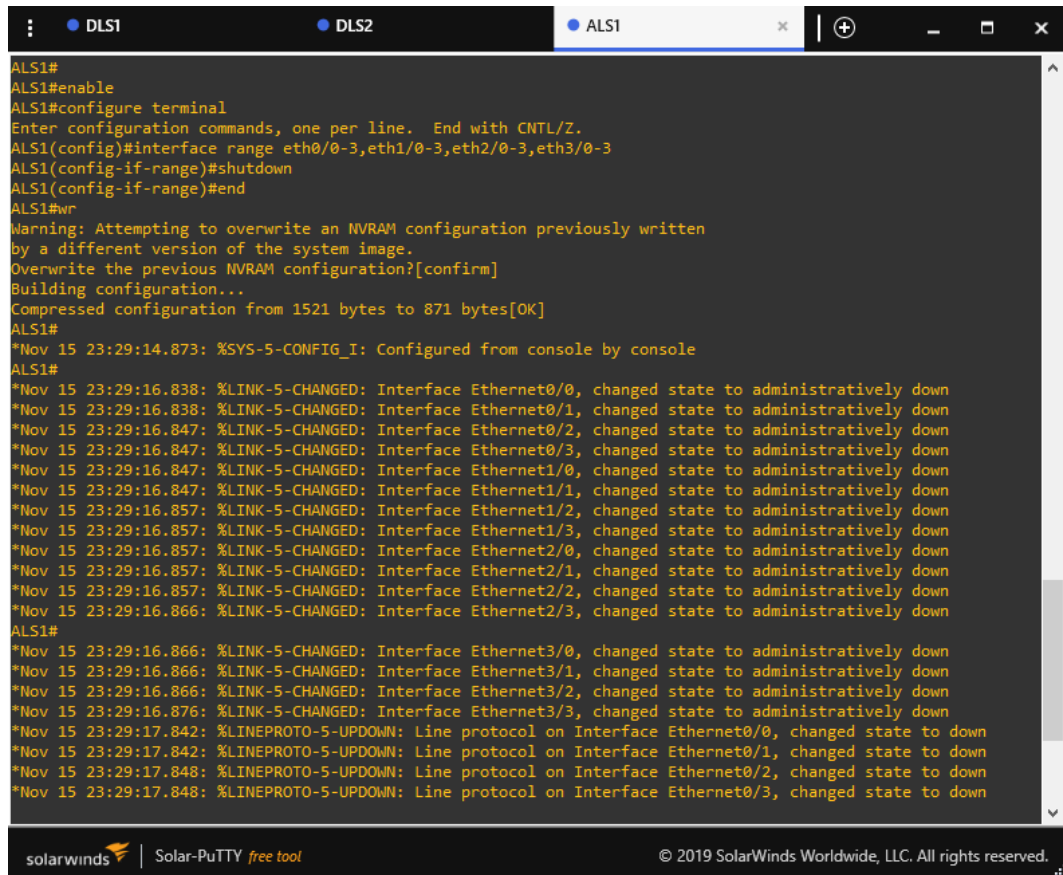

```
ALS1#
ALS1#enable
ALS1#configure terminal
Enter configuration commands, one per line. End with CNTL/Z.
ALS1(config)#interface range eth0/0-3,eth1/0-3,eth2/0-3,eth3/0-3
ALS1(config-if-range)#shutdown
ALS1(config-if-range)#end
ALS1#wr
Warning: Attempting to overwrite an NVRAM configuration previously written
by a different version of the system image.
Overwrite the previous NVRAM configuration?[confirm]
Building configuration...
Compressed configuration from 1521 bytes to 871 bytes[OK]
ALS1#
*Nov 15 23:29:14.873: %SYS-5-CONFIG_I: Configured from console by console
ALS1#
*Nov 15 23:29:16.838: %LINK-5-CHANGED: Interface Ethernet0/0, changed state to administratively down
*Nov 15 23:29:16.838: %LINK-5-CHANGED: Interface Ethernet0/1, changed state to administratively down
*Nov 15 23:29:16.847: %LINK-5-CHANGED: Interface Ethernet0/2, changed state to administratively down
*Nov 15 23:29:16.847: %LINK-5-CHANGED: Interface Ethernet0/3, changed state to administratively down
*Nov 15 23:29:16.847: %LINK-5-CHANGED: Interface Ethernet1/0, changed state to administratively down
*Nov 15 23:29:16.847: %LINK-5-CHANGED: Interface Ethernet1/1, changed state to administratively down
*Nov 15 23:29:16.857: %LINK-5-CHANGED: Interface Ethernet1/2, changed state to administratively down
*Nov 15 23:29:16.857: %LINK-5-CHANGED: Interface Ethernet1/3, changed state to administratively down
*Nov 15 23:29:16.857: %LINK-5-CHANGED: Interface Ethernet2/0, changed state to administratively down
*Nov 15 23:29:16.857: %LINK-5-CHANGED: Interface Ethernet2/1, changed state to administratively down
*Nov 15 23:29:16.857: %LINK-5-CHANGED: Interface Ethernet2/2, changed state to administratively down
*Nov 15 23:29:16.866: %LINK-5-CHANGED: Interface Ethernet2/3, changed state to administratively down
ALS1#
*Nov 15 23:29:16.866: %LINK-5-CHANGED: Interface Ethernet3/0, changed state to administratively down
*Nov 15 23:29:16.866: %LINK-5-CHANGED: Interface Ethernet3/1, changed state to administratively down
*Nov 15 23:29:16.876: %LINK-5-CHANGED: Interface Ethernet3/2, changed state to administratively down
*Nov 15 23:29:16.876: %LINK-5-CHANGED: Interface Ethernet3/3, changed state to administratively down
*Nov 15 23:29:17.842: %LINEPROTO-5-UPDOWN: Line protocol on Interface Ethernet0/0, changed state to down
*Nov 15 23:29:17.842: %LINEPROTO-5-UPDOWN: Line protocol on Interface Ethernet0/1, changed state to down
*Nov 15 23:29:17.848: %LINEPROTO-5-UPDOWN: Line protocol on Interface Ethernet0/2, changed state to down
*Nov 15 23:29:17.848: %LINEPROTO-5-UPDOWN: Line protocol on Interface Ethernet0/3, changed state to down
```

Figura 18. Interfaces apagadas en ALS1

Comandos

```
enable
configure terminal
interface range eth0/0-3,eth1/0-3,eth2/0-3,eth3/0-3
shutdown
end
wr
```

Switch ALS2

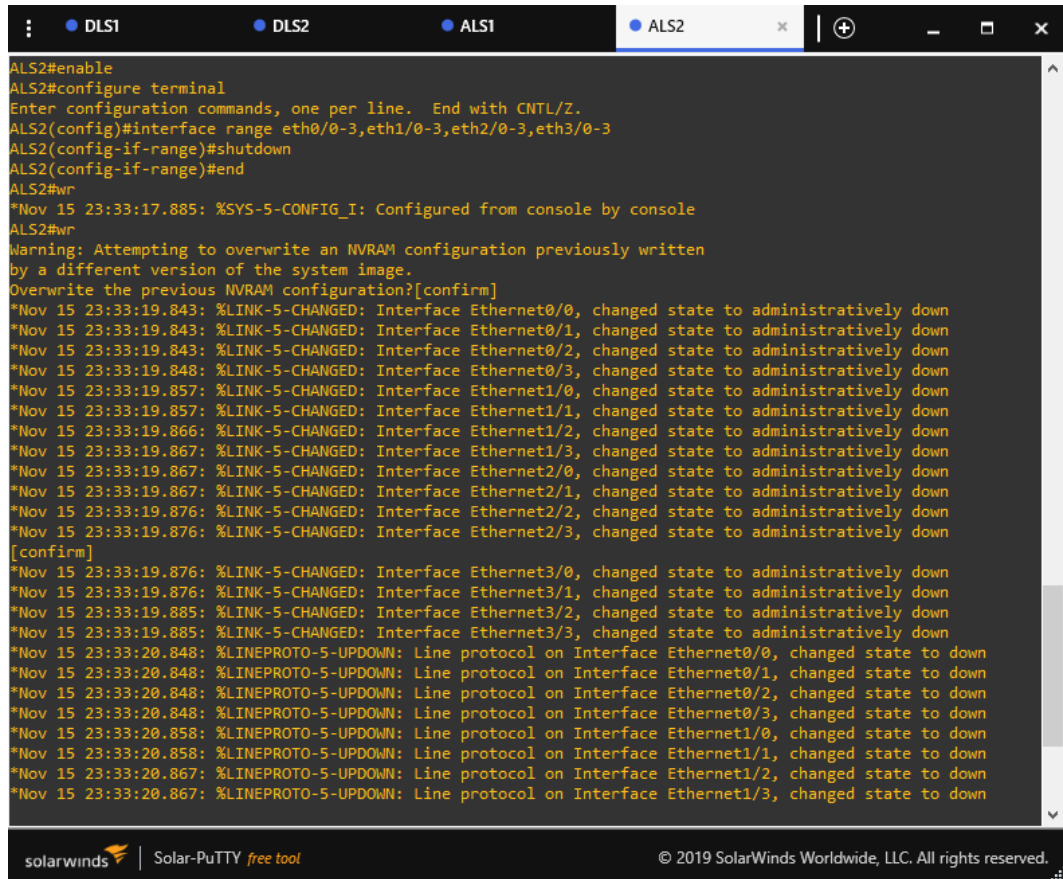

```
ALS2#enable
ALS2#configure terminal
Enter configuration commands, one per line. End with CNTL/Z.
ALS2(config)#interface range eth0/0-3,eth1/0-3,eth2/0-3,eth3/0-3
ALS2(config-if-range)#shutdown
ALS2(config-if-range)#end
ALS2#wr
*Nov 15 23:33:17.885: %SYS-5-CONFIG_I: Configured from console by console
ALS2#wr
Warning: Attempting to overwrite an NVRAM configuration previously written
by a different version of the system image.
Overwrite the previous NVRAM configuration?[confirm]
*Nov 15 23:33:19.843: %LINK-5-CHANGED: Interface Ethernet0/0, changed state to administratively down
*Nov 15 23:33:19.843: %LINK-5-CHANGED: Interface Ethernet0/1, changed state to administratively down
*Nov 15 23:33:19.843: %LINK-5-CHANGED: Interface Ethernet0/2, changed state to administratively down
*Nov 15 23:33:19.848: %LINK-5-CHANGED: Interface Ethernet0/3, changed state to administratively down
*Nov 15 23:33:19.857: %LINK-5-CHANGED: Interface Ethernet1/0, changed state to administratively down
*Nov 15 23:33:19.857: %LINK-5-CHANGED: Interface Ethernet1/1, changed state to administratively down
*Nov 15 23:33:19.866: %LINK-5-CHANGED: Interface Ethernet1/2, changed state to administratively down
*Nov 15 23:33:19.867: %LINK-5-CHANGED: Interface Ethernet1/3, changed state to administratively down
*Nov 15 23:33:19.867: %LINK-5-CHANGED: Interface Ethernet2/0, changed state to administratively down
*Nov 15 23:33:19.867: %LINK-5-CHANGED: Interface Ethernet2/1, changed state to administratively down
*Nov 15 23:33:19.876: %LINK-5-CHANGED: Interface Ethernet2/2, changed state to administratively down
*Nov 15 23:33:19.876: %LINK-5-CHANGED: Interface Ethernet2/3, changed state to administratively down
[confirm]
*Nov 15 23:33:19.876: %LINK-5-CHANGED: Interface Ethernet3/0, changed state to administratively down
*Nov 15 23:33:19.876: %LINK-5-CHANGED: Interface Ethernet3/1, changed state to administratively down
*Nov 15 23:33:19.885: %LINK-5-CHANGED: Interface Ethernet3/2, changed state to administratively down
*Nov 15 23:33:19.885: %LINK-5-CHANGED: Interface Ethernet3/3, changed state to administratively down
*Nov 15 23:33:20.848: %LINEPROTO-5-UPDOWN: Line protocol on Interface Ethernet0/0, changed state to down
*Nov 15 23:33:20.848: %LINEPROTO-5-UPDOWN: Line protocol on Interface Ethernet0/1, changed state to down
*Nov 15 23:33:20.848: %LINEPROTO-5-UPDOWN: Line protocol on Interface Ethernet0/2, changed state to down
*Nov 15 23:33:20.848: %LINEPROTO-5-UPDOWN: Line protocol on Interface Ethernet0/3, changed state to down
*Nov 15 23:33:20.858: %LINEPROTO-5-UPDOWN: Line protocol on Interface Ethernet1/0, changed state to down
*Nov 15 23:33:20.858: %LINEPROTO-5-UPDOWN: Line protocol on Interface Ethernet1/1, changed state to down
*Nov 15 23:33:20.867: %LINEPROTO-5-UPDOWN: Line protocol on Interface Ethernet1/2, changed state to down
*Nov 15 23:33:20.867: %LINEPROTO-5-UPDOWN: Line protocol on Interface Ethernet1/3, changed state to down
```

Figura 19. Interfaces apagadas en ALS2

Comandos

```
enable
configure terminal
interface range eth0/0-3,eth1/0-3,eth2/0-3,eth3/0-3
shutdown
end
wr
```

Con el comando show ip interface brief, verificamos que efectivamente las interfaces se encuentran apagadas en cada switch.

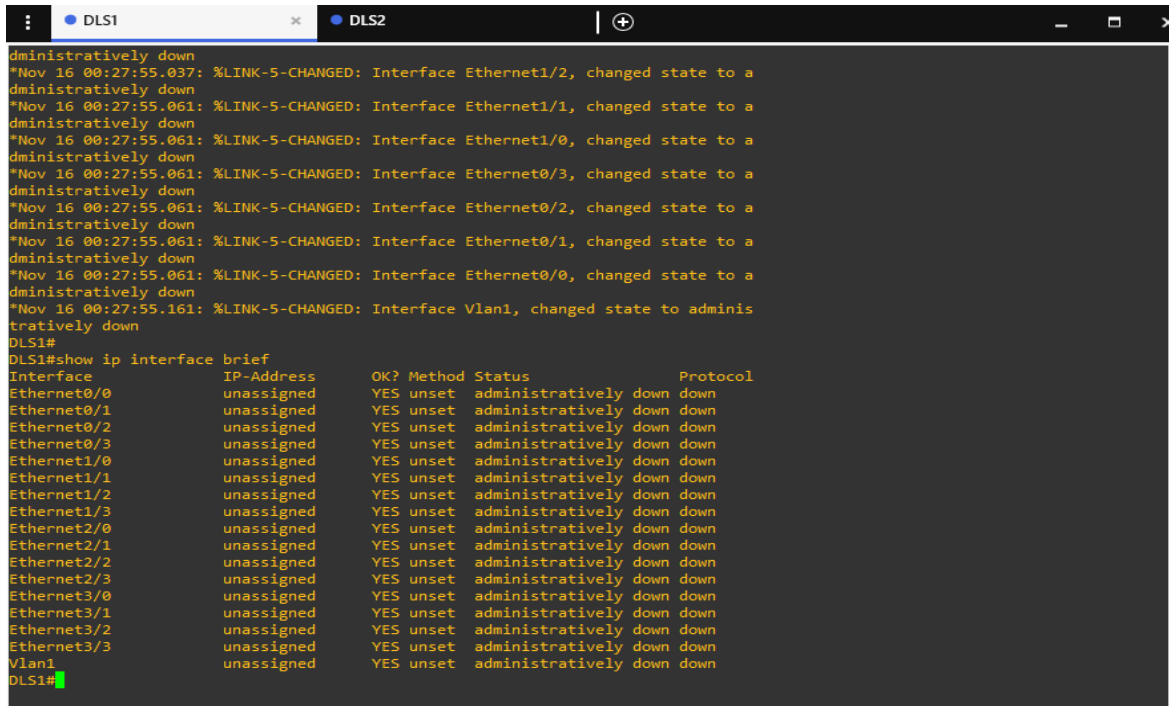

```
DLS1#
*Nov 16 00:27:55.037: %LINK-5-CHANGED: Interface Ethernet1/2, changed state to a
administratively down
*Nov 16 00:27:55.061: %LINK-5-CHANGED: Interface Ethernet1/1, changed state to a
administratively down
*Nov 16 00:27:55.061: %LINK-5-CHANGED: Interface Ethernet1/0, changed state to a
administratively down
*Nov 16 00:27:55.061: %LINK-5-CHANGED: Interface Ethernet0/3, changed state to a
administratively down
*Nov 16 00:27:55.061: %LINK-5-CHANGED: Interface Ethernet0/2, changed state to a
administratively down
*Nov 16 00:27:55.061: %LINK-5-CHANGED: Interface Ethernet0/1, changed state to a
administratively down
*Nov 16 00:27:55.061: %LINK-5-CHANGED: Interface Ethernet0/0, changed state to a
administratively down
*Nov 16 00:27:55.161: %LINK-5-CHANGED: Interface Vlan1, changed state to adminis
tratively down
DLS1#
DLS1#show ip interface brief
Interface          IP-Address      OK? Method Status          Protocol
Ethernet0/0        unassigned     YES unset    administratively down down
Ethernet0/1        unassigned     YES unset    administratively down down
Ethernet0/2        unassigned     YES unset    administratively down down
Ethernet0/3        unassigned     YES unset    administratively down down
Ethernet1/0        unassigned     YES unset    administratively down down
Ethernet1/1        unassigned     YES unset    administratively down down
Ethernet1/2        unassigned     YES unset    administratively down down
Ethernet1/3        unassigned     YES unset    administratively down down
Ethernet2/0        unassigned     YES unset    administratively down down
Ethernet2/1        unassigned     YES unset    administratively down down
Ethernet2/2        unassigned     YES unset    administratively down down
Ethernet2/3        unassigned     YES unset    administratively down down
Ethernet3/0        unassigned     YES unset    administratively down down
Ethernet3/1        unassigned     YES unset    administratively down down
Ethernet3/2        unassigned     YES unset    administratively down down
Ethernet3/3        unassigned     YES unset    administratively down down
Vlan1              unassigned     YES unset    administratively down down
DLS1#
```

Figura 20. Interfaces apagadas en DLS1

```

DLS1
DLS2
administratively down
*Nov 16 00:27:55.060: %LINK-5-CHANGED: Interface Ethernet1/2, changed state to a
administratively down
*Nov 16 00:27:55.060: %LINK-5-CHANGED: Interface Ethernet1/1, changed state to a
administratively down
*Nov 16 00:27:55.060: %LINK-5-CHANGED: Interface Ethernet1/0, changed state to a
administratively down
*Nov 16 00:27:55.060: %LINK-5-CHANGED: Interface Ethernet0/3, changed state to a
administratively down
*Nov 16 00:27:55.060: %LINK-5-CHANGED: Interface Ethernet0/2, changed state to a
administratively down
*Nov 16 00:27:55.060: %LINK-5-CHANGED: Interface Ethernet0/1, changed state to a
administratively down
*Nov 16 00:27:55.060: %LINK-5-CHANGED: Interface Ethernet0/0, changed state to a
administratively down
*Nov 16 00:27:55.188: %LINK-5-CHANGED: Interface Vlan1, changed state to adminis
tratively down
DLS2#
DLS2#show ip interface brief
Interface      IP-Address      OK? Method Status          Protocol
Ethernet0/0    unassigned      YES unset  administratively down down
Ethernet0/1    unassigned      YES unset  administratively down down
Ethernet0/2    unassigned      YES unset  administratively down down
Ethernet0/3    unassigned      YES unset  administratively down down
Ethernet1/0    unassigned      YES unset  administratively down down
Ethernet1/1    unassigned      YES unset  administratively down down
Ethernet1/2    unassigned      YES unset  administratively down down
Ethernet1/3    unassigned      YES unset  administratively down down
Ethernet2/0    unassigned      YES unset  administratively down down
Ethernet2/1    unassigned      YES unset  administratively down down
Ethernet2/2    unassigned      YES unset  administratively down down
Ethernet2/3    unassigned      YES unset  administratively down down
Ethernet3/0    unassigned      YES unset  administratively down down
Ethernet3/1    unassigned      YES unset  administratively down down
Ethernet3/2    unassigned      YES unset  administratively down down
Ethernet3/3    unassigned      YES unset  administratively down down
Vlan1          unassigned      YES unset  administratively down down
DLS2#

```

Figura 21. Interfaces apagadas en DLS2

```

DLS1
DLS2
ALS1
administratively down
*Nov 16 00:27:55.065: %LINK-5-CHANGED: Interface Ethernet1/2, changed state to a
administratively down
*Nov 16 00:27:55.065: %LINK-5-CHANGED: Interface Ethernet1/1, changed state to a
administratively down
*Nov 16 00:27:55.065: %LINK-5-CHANGED: Interface Ethernet1/0, changed state to a
administratively down
*Nov 16 00:27:55.065: %LINK-5-CHANGED: Interface Ethernet0/3, changed state to a
administratively down
*Nov 16 00:27:55.065: %LINK-5-CHANGED: Interface Ethernet0/2, changed state to a
administratively down
*Nov 16 00:27:55.065: %LINK-5-CHANGED: Interface Ethernet0/1, changed state to a
administratively down
*Nov 16 00:27:55.065: %LINK-5-CHANGED: Interface Ethernet0/0, changed state to a
administratively down
*Nov 16 00:27:55.170: %LINK-5-CHANGED: Interface Vlan1, changed state to adminis
tratively down
ALS1#
ALS1#show ip interface brief
Interface      IP-Address      OK? Method Status          Protocol
Ethernet0/0    unassigned      YES unset  administratively down down
Ethernet0/1    unassigned      YES unset  administratively down down
Ethernet0/2    unassigned      YES unset  administratively down down
Ethernet0/3    unassigned      YES unset  administratively down down
Ethernet1/0    unassigned      YES unset  administratively down down
Ethernet1/1    unassigned      YES unset  administratively down down
Ethernet1/2    unassigned      YES unset  administratively down down
Ethernet1/3    unassigned      YES unset  administratively down down
Ethernet2/0    unassigned      YES unset  administratively down down
Ethernet2/1    unassigned      YES unset  administratively down down
Ethernet2/2    unassigned      YES unset  administratively down down
Ethernet2/3    unassigned      YES unset  administratively down down
Ethernet3/0    unassigned      YES unset  administratively down down
Ethernet3/1    unassigned      YES unset  administratively down down
Ethernet3/2    unassigned      YES unset  administratively down down
Ethernet3/3    unassigned      YES unset  administratively down down
Vlan1          unassigned      YES unset  administratively down down
ALS1#

```

Figura 22. Interfaces apagadas en ALS1

```

DLS1 DLS2 ALS1 ALS2
administratively down
*Nov 16 00:27:55.065: %LINK-5-CHANGED: Interface Ethernet1/2, changed state to a
administratively down
*Nov 16 00:27:55.065: %LINK-5-CHANGED: Interface Ethernet1/1, changed state to a
administratively down
*Nov 16 00:27:55.065: %LINK-5-CHANGED: Interface Ethernet1/0, changed state to a
administratively down
*Nov 16 00:27:55.065: %LINK-5-CHANGED: Interface Ethernet0/3, changed state to a
administratively down
*Nov 16 00:27:55.065: %LINK-5-CHANGED: Interface Ethernet0/2, changed state to a
administratively down
*Nov 16 00:27:55.065: %LINK-5-CHANGED: Interface Ethernet0/1, changed state to a
administratively down
*Nov 16 00:27:55.065: %LINK-5-CHANGED: Interface Ethernet0/0, changed state to a
administratively down
*Nov 16 00:27:55.179: %LINK-5-CHANGED: Interface Vlan1, changed state to adminis
tratively down
ALS2#
ALS2#show ip interface brief
Interface IP-Address OK? Method Status Protocol
Ethernet0/0 unassigned YES unset administratively down down
Ethernet0/1 unassigned YES unset administratively down down
Ethernet0/2 unassigned YES unset administratively down down
Ethernet0/3 unassigned YES unset administratively down down
Ethernet1/0 unassigned YES unset administratively down down
Ethernet1/1 unassigned YES unset administratively down down
Ethernet1/2 unassigned YES unset administratively down down
Ethernet1/3 unassigned YES unset administratively down down
Ethernet2/0 unassigned YES unset administratively down down
Ethernet2/1 unassigned YES unset administratively down down
Ethernet2/2 unassigned YES unset administratively down down
Ethernet2/3 unassigned YES unset administratively down down
Ethernet3/0 unassigned YES unset administratively down down
Ethernet3/1 unassigned YES unset administratively down down
Ethernet3/2 unassigned YES unset administratively down down
Ethernet3/3 unassigned YES unset administratively down down
Vlan1 unassigned YES unset administratively down down
ALS2#

```

Figura 23. Interfaces apagadas en ALS2

- b. Configurar los puertos troncales y Port-channels tal como se muestra en el diagrama.

La conexión entre DLS1 y DLS2 será un EtherChannel capa-3 utilizando LACP. Para DLS1 se utilizará la dirección IP 10.12.12.1/30 y para DLS2 utilizará 10.12.12.2/30.

Punto 1.

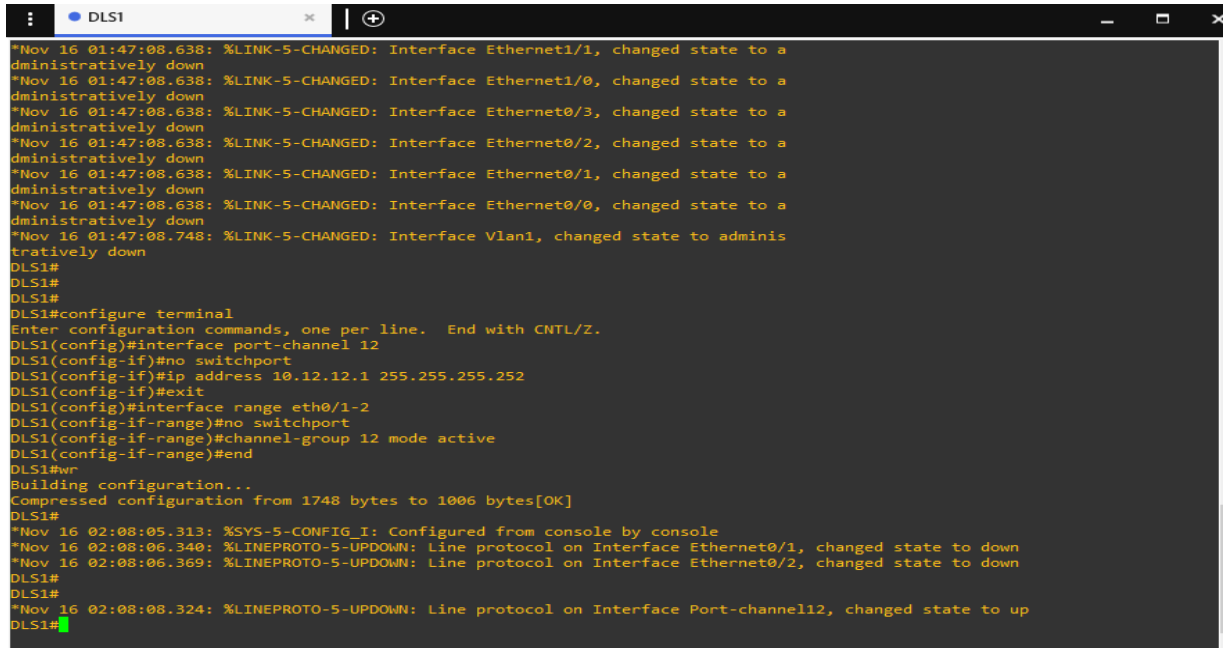

```
DLS1
*Nov 16 01:47:08.638: %LINK-5-CHANGED: Interface Ethernet1/1, changed state to a
dministratively down
*Nov 16 01:47:08.638: %LINK-5-CHANGED: Interface Ethernet1/0, changed state to a
dministratively down
*Nov 16 01:47:08.638: %LINK-5-CHANGED: Interface Ethernet0/3, changed state to a
dministratively down
*Nov 16 01:47:08.638: %LINK-5-CHANGED: Interface Ethernet0/2, changed state to a
dministratively down
*Nov 16 01:47:08.638: %LINK-5-CHANGED: Interface Ethernet0/1, changed state to a
dministratively down
*Nov 16 01:47:08.638: %LINK-5-CHANGED: Interface Ethernet0/0, changed state to a
dministratively down
*Nov 16 01:47:08.748: %LINK-5-CHANGED: Interface Vlan1, changed state to adminis
tratively down
DLS1#
DLS1#
DLS1#
DLS1#configure terminal
Enter configuration commands, one per line. End with CNTL/Z.
DLS1(config)#interface port-channel 12
DLS1(config-if)#no switchport
DLS1(config-if)#ip address 10.12.12.1 255.255.255.252
DLS1(config-if)#exit
DLS1(config)#interface range eth0/1-2
DLS1(config-if-range)#no switchport
DLS1(config-if-range)#channel-group 12 mode active
DLS1(config-if-range)#end
DLS1#wr
Building configuration...
Compressed configuration from 1748 bytes to 1006 bytes[OK]
DLS1#
*Nov 16 02:08:05.313: %SYS-5-CONFIG_I: Configured from console by console
*Nov 16 02:08:06.340: %LINEPROTO-5-UPDOWN: Line protocol on Interface Ethernet0/1, changed state to down
*Nov 16 02:08:06.369: %LINEPROTO-5-UPDOWN: Line protocol on Interface Ethernet0/2, changed state to down
DLS1#
DLS1#
*Nov 16 02:08:08.324: %LINEPROTO-5-UPDOWN: Line protocol on Interface Port-channel12, changed state to up
DLS1#
```

Figura 24. Etherchannel LACP Capa-3 en DLS1

Comandos

```
configure terminal
interface port-channel 12
no switchport
ip address 10.12.12.1 255.255.255.252
exit
interface range eth0/1-2
no switchport
channel-group 12 mode active
end
```

```
DLS2
administratively down
*Nov 16 02:38:46.286: %LINK-5-CHANGED: Interface Ethernet1/1, changed state to a
administratively down
*Nov 16 02:38:46.287: %LINK-5-CHANGED: Interface Ethernet1/0, changed state to a
administratively down
*Nov 16 02:38:46.287: %LINK-5-CHANGED: Interface Ethernet0/3, changed state to a
administratively down
*Nov 16 02:38:46.287: %LINK-5-CHANGED: Interface Ethernet0/2, changed state to a
administratively down
*Nov 16 02:38:46.287: %LINK-5-CHANGED: Interface Ethernet0/1, changed state to a
administratively down
*Nov 16 02:38:46.287: %LINK-5-CHANGED: Interface Ethernet0/0, changed state to a
administratively down
*Nov 16 02:38:46.613: %LINK-5-CHANGED: Interface Vlan1, changed state to adminis
tratively down
DLS2#
DLS2#
DLS2#
DLS2#configure terminal
Enter configuration commands, one per line. End with CNTL/Z.
DLS2(config)#interface port-channel 12
DLS2(config-if)#no switchport
DLS2(config-if)#ip address 10.12.12.2 255.255.255.252
DLS2(config-if)#exit
DLS2(config)#interface range eth0/1-2
DLS2(config-if-range)#no switchport
DLS2(config-if-range)#channel-group 12 mode active
DLS2(config-if-range)#end
DLS2#wr
Building configuration...
Compressed configuration from 1748 bytes to 1007 bytes[OK]
DLS2#
*Nov 16 02:40:28.550: %SYS-5-CONFIG I: Configured from console by console
*Nov 16 02:40:29.577: %LINEPROTO-5-UPDOWN: Line protocol on Interface Ethernet0/1, changed state to down
*Nov 16 02:40:29.577: %LINEPROTO-5-UPDOWN: Line protocol on Interface Ethernet0/2, changed state to down
DLS2#
*Nov 16 02:40:31.522: %LINEPROTO-5-UPDOWN: Line protocol on Interface Port-channel12, changed state to up
DLS2#
```

Figura 25. Etherchannel LACP Capa-3 en DLS2

Comandos

```
configure terminal
interface port-channel 12
no switchport
ip address 10.12.12.2 255.255.255.252
exit
interface range eth0/1-2
no switchport
channel-group 12 mode active
end
wr
```

Con el comando `show etherchannel summary`, verificamos configuración etherchannel capa-3 en DLS1 y DLS2.

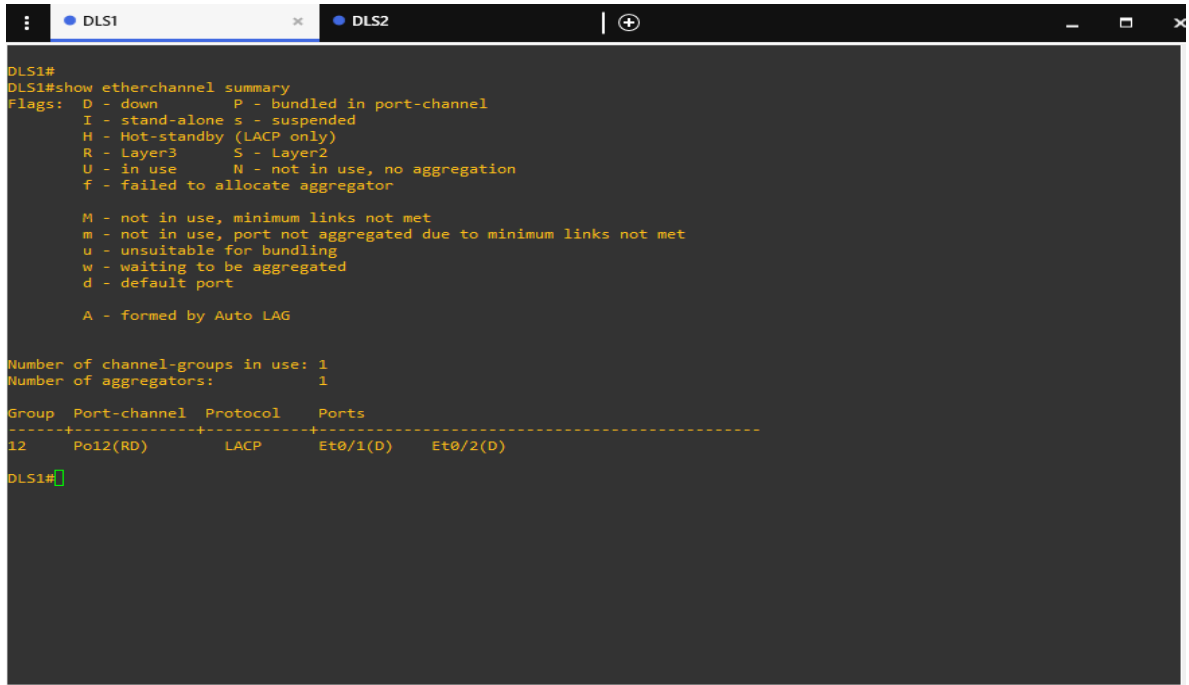

```
DLS1#
DLS1#show etherchannel summary
Flags: D - down          P - bundled in port-channel
       I - stand-alone  s - suspended
       H - Hot-standby (LACP only)
       R - Layer3       S - Layer2
       U - in use       N - not in use, no aggregation
       f - failed to allocate aggregator

       M - not in use, minimum links not met
       m - not in use, port not aggregated due to minimum links not met
       u - unsuitable for bundling
       w - waiting to be aggregated
       d - default port

       A - formed by Auto LAG

Number of channel-groups in use: 1
Number of aggregators:          1

Group  Port-channel  Protocol    Ports
-----+-----+-----+-----
12     Po12(RD)       LACP        Et0/1(D)  Et0/2(D)
DLS1#
```

Figura 26. Configuración Etherchannel LACP Capa-3 en DLS1

```
DLS2#show etherchannel summary
Flags: D - down          P - bundled in port-channel
       I - stand-alone  S - suspended
       H - Hot-standby (LACP only)
       R - Layer3       S - Layer2
       U - in use       N - not in use, no aggregation
       f - failed to allocate aggregator

       M - not in use, minimum links not met
       m - not in use, port not aggregated due to minimum links not met
       u - unsuitable for bundling
       w - waiting to be aggregated
       d - default port

       A - formed by Auto LAG

Number of channel-groups in use: 1
Number of aggregators:          1

Group  Port-channel  Protocol    Ports
-----+-----+-----+-----
12     Po12(RD)        LACP        Et0/1(D)  Et0/2(D)

DLS2#
```

Figura 27. Configuración Etherchannel LACP Capa-3 en DLS2

Los Port-channels en las interfaces Fa1/1 y Fa1/2 utilizarán LACP.

```
DLS1#
DLS1#configure terminal
Enter configuration commands, one per line. End with CNTL/Z.
DLS1(config)#interface range eth1/1,eth1/2
DLS1(config-if-range)#switchport trunk encapsulation dot1q
DLS1(config-if-range)#switchport mode trunk
DLS1(config-if-range)#channel-group 1 mode active
DLS1(config-if-range)#no shutdown
DLS1(config-if-range)#exit
DLS1(config)#end
DLS1#wr
Building configuration...
Compressed configuration from 1934 bytes to 1107 bytes[OK]
DLS1#
*Nov 16 03:14:31.098: %SYS-5-CONFIG_I: Configured from console by console
DLS1#
```

Figura 28. Enlace troncal Etherchannel 1 en DLS1

```
DLS1
DLS2
administratively down
*Nov 16 03:24:41.906: %LINK-5-CHANGED: Interface Ethernet0/3, changed state to a
administratively down
*Nov 16 03:24:41.906: %LINK-5-CHANGED: Interface Ethernet0/0, changed state to a
administratively down
*Nov 16 03:24:42.301: %LINK-5-CHANGED: Interface Vlan1, changed state to adminis
tratively down
*Nov 16 03:24:43.186: %LINEPROTO-5-UPDOWN: Line protocol on Interface Port-chann
el12, changed state to up
*Nov 16 03:24:43.218: %LINEPROTO-5-UPDOWN: Line protocol on Interface Ethernet0/
1, changed state to down
*Nov 16 03:24:43.241: %LINEPROTO-5-UPDOWN: Line protocol on Interface Ethernet0/
2, changed state to down
DLS2#
DLS2#
DLS2#
DLS2#configure terminal
Enter configuration commands, one per line. End with CNTL/Z.
DLS2(config)#interface range eth1/1,eth1/2
DLS2(config-if-range)#switchport trunk encapsulation dot1q
DLS2(config-if-range)#switchport mode trunk
DLS2(config-if-range)#channel-group 2 mode active
Creating a port-channel interface Port-channel 2

DLS2(config-if-range)#no shutdown
DLS2(config-if-range)#end
DLS2#wr
*Nov 16 03:25:24.637: %SYS-5-CONFIG_I: Configured from console by console
DLS2#wr
Building configuration...
Compressed configuration from 1934 bytes to 1109 bytes[OK]
DLS2#
*Nov 16 03:25:26.640: %LINK-3-UPDOWN: Interface Ethernet1/1, changed state to up
*Nov 16 03:25:26.640: %LINK-3-UPDOWN: Interface Ethernet1/2, changed state to up
DLS2#
*Nov 16 03:25:35.534: %EC-5-L3DONTBNDL2: Et1/1 suspended: LACP currently not enabled on the remote port.
*Nov 16 03:25:35.905: %EC-5-L3DONTBNDL2: Et1/2 suspended: LACP currently not enabled on the remote port.
DLS2#
```

Figura 29. Enlace troncal Etherchannel Po2 en DLS2

```
administratively down
*Nov 16 03:24:41.873: %LINK-5-CHANGED: Interface Ethernet0/3, changed state to a
administratively down
*Nov 16 03:24:41.873: %LINK-5-CHANGED: Interface Ethernet0/2, changed state to a
administratively down
*Nov 16 03:24:41.873: %LINK-5-CHANGED: Interface Ethernet0/1, changed state to a
administratively down
*Nov 16 03:24:41.873: %LINK-5-CHANGED: Interface Ethernet0/0, changed state to a
administratively down
*Nov 16 03:24:42.186: %LINK-5-CHANGED: Interface Vlan1, changed state to adminis
tratively down
ALS1#
ALS1#
ALS1#
ALS1#configure terminal
Enter configuration commands, one per line. End with CNTL/Z.
ALS1(config)#interface range eth1/1,eth1/2
ALS1(config-if-range)#switchport trunk encapsulation dot1q
ALS1(config-if-range)#switchport mode trunk
ALS1(config-if-range)#channel-group 1 mode active
Creating a port-channel interface Port-channel 1

ALS1(config-if-range)#no shutdown
ALS1(config-if-range)#end
ALS1#wr
*Nov 16 03:33:55.739: %SYS-5-CONFIG_I: Configured from console by console
ALS1#wr
Building configuration...
Compressed configuration from 1707 bytes to 984 bytes[OK]
ALS1#
*Nov 16 03:33:57.763: %LINK-3-UPDOWN: Interface Ethernet1/1, changed state to up
*Nov 16 03:33:57.763: %LINK-3-UPDOWN: Interface Ethernet1/2, changed state to up
*Nov 16 03:33:58.770: %LINEPROTO-5-UPDOWN: Line protocol on Interface Ethernet1/1, changed state to up
*Nov 16 03:33:58.770: %LINEPROTO-5-UPDOWN: Line protocol on Interface Ethernet1/2, changed state to up
ALS1#
*Nov 16 03:34:05.496: %LINEPROTO-5-UPDOWN: Line protocol on Interface Port-channel1, changed state to up
ALS1#
ALS1#
```

Figura 30. Enlace troncal Etherchannel Po1 en ALS1

```
ALS2#configure terminal
Enter configuration commands, one per line. End with CNTL/Z.
ALS2(config)#interface range eth1/1,eth1/2
ALS2(config-if-range)#switchport trunk encapsulation dot1q
ALS2(config-if-range)#switchport mode trunk
ALS2(config-if-range)#channel-group 2 mode active
Creating a port-channel interface Port-channel 2

ALS2(config-if-range)#no shutdown
ALS2(config-if-range)#end
ALS2#wr
Building configuration...
Compressed configuration from 1707 bytes to 985 bytes[OK]
ALS2#
*Nov 16 03:35:36.181: %SYS-5-CONFIG_I: Configured from console by console
ALS2#
*Nov 16 03:35:38.189: %LINK-3-UPDOWN: Interface Ethernet1/1, changed state to up
*Nov 16 03:35:38.191: %LINK-3-UPDOWN: Interface Ethernet1/2, changed state to up
ALS2#
*Nov 16 03:35:40.210: %LINEPROTO-5-UPDOWN: Line protocol on Interface Ethernet1/1, changed state to up
*Nov 16 03:35:40.211: %LINEPROTO-5-UPDOWN: Line protocol on Interface Ethernet1/2, changed state to up
ALS2#
*Nov 16 03:35:45.891: %LINEPROTO-5-UPDOWN: Line protocol on Interface Port-channel2, changed state to up
ALS2#
```

Figura 31. Enlace troncal Etherchannel Po1 en ALS2

Con los comandos show interfaces trunk y show etherchannel summary, verificamos configuración enlace troncal etherchannel en cada uno de los switch.

```
DLS1#
DLS1#show interfaces trunk

Port      Mode           Encapsulation  Status        Native vlan
Po1       on             802.1q         trunking      1

Port      Vlans allowed on trunk
Po1       1-4094

Port      Vlans allowed and active in management domain
Po1       1

Port      Vlans in spanning tree forwarding state and not pruned
Po1       1
DLS1#
```

Figura 32. Enlace troncal Etherchannel en DLS1

```
DLS1#
DLS1#show etherchannel summary
Flags: D - down          P - bundled in port-channel
       I - stand-alone  s - suspended
       H - Hot-standby (LACP only)
       R - Layer3       S - Layer2
       U - in use       N - not in use, no aggregation
       f - failed to allocate aggregator

       M - not in use, minimum links not met
       m - not in use, port not aggregated due to minimum links not met
       u - unsuitable for bundling
       w - waiting to be aggregated
       d - default port

       A - formed by Auto LAG

Number of channel-groups in use: 2
Number of aggregators:          2

Group  Port-channel  Protocol    Ports
-----+-----+-----+-----
1      Po1(SU)       LACP        Et1/1(P)  Et1/2(P)
12     Po12(RD)      LACP        Et0/1(D)  Et0/2(D)

DLS1#
```

solarwinds | Solar-PuTTY free tool | © 2019 SolarWinds Worldwide, LLC. All rights reserved.

Figura 33. Etherchannel capa2 Po1 en DLS1

```

DLS2#
*Nov 16 03:35:45.876: %LINEPROTO-5-UPDOWN: Line protocol on Interface Port-channel12, changed state to up
DLS2#
DLS2#show interfaces trunk

Port      Mode           Encapsulation  Status        Native vlan
Po2       on             802.1q         trunking      1

Port      Vlans allowed on trunk
Po2       1-4094

Port      Vlans allowed and active in management domain
Po2       1

Port      Vlans in spanning tree forwarding state and not pruned
Po2       1
DLS2#

```

Figura 34. Enlace troncal Etherchannel Po2 en DLS2

```

DLS2#
DLS2#show etherchannel summary
Flags: D - down          P - bundled in port-channel
       I - stand-alone s - suspended
       H - Hot-standby (LACP only)
       R - Layer3        S - Layer2
       U - in use        N - not in use, no aggregation
       f - failed to allocate aggregator

       M - not in use, minimum links not met
       m - not in use, port not aggregated due to minimum links not met
       u - unsuitable for bundling
       w - waiting to be aggregated
       d - default port

       A - formed by Auto LAG

Number of channel-groups in use: 2
Number of aggregators:          2

Group  Port-channel  Protocol    Ports
-----+-----+-----+-----
2      Po2(SU)       LACP        Et1/1(P)  Et1/2(P)
12     Po12(RD)      LACP        Et0/1(D)  Et0/2(D)
DLS2#

```

Figura 35. Etherchannel capa2 Po2 en DLS2

```

ALS1#show interfaces trunk

Port      Mode           Encapsulation  Status        Native vlan
Po1       on             802.1q         trunking      1

Port      Vlans allowed on trunk
Po1       1-4094

Port      Vlans allowed and active in management domain
Po1       1

Port      Vlans in spanning tree forwarding state and not pruned
Po1       1
ALS1#show etherchannel summary
Flags: D - down          P - bundled in port-channel
       I - stand-alone   s - suspended
       H - Hot-standby (LACP only)
       R - Layer3       S - Layer2
       U - in use       N - not in use, no aggregation
       f - failed to allocate aggregator

       M - not in use, minimum links not met
       m - not in use, port not aggregated due to minimum links not met
       u - unsuitable for bundling
       w - waiting to be aggregated
       d - default port

       A - formed by Auto LAG

Number of channel-groups in use: 1
Number of aggregators:          1

Group  Port-channel  Protocol    Ports
-----+-----+-----+-----
1      Po1(SU)       LACP        Et1/1(P)  Et1/2(P)

ALS1#

```

Figura 36. Enlace troncal Etherchannel Po2 en ALS1 & Etherchannel capa2 Po2 en ALS1

```

ALS2#show interfaces trunk

Port      Mode           Encapsulation  Status        Native vlan
Po2       on             802.1q         trunking      1

Port      Vlans allowed on trunk
Po2       1-4094

Port      Vlans allowed and active in management domain
Po2       1

Port      Vlans in spanning tree forwarding state and not pruned
Po2       1
ALS2#show etherchannel summary
Flags: D - down          P - bundled in port-channel
       I - stand-alone   s - suspended
       H - Hot-standby (LACP only)
       R - Layer3       S - Layer2
       U - in use       N - not in use, no aggregation
       f - failed to allocate aggregator

       M - not in use, minimum links not met
       m - not in use, port not aggregated due to minimum links not met
       u - unsuitable for bundling
       w - waiting to be aggregated
       d - default port

       A - formed by Auto LAG

Number of channel-groups in use: 1
Number of aggregators:          1

Group  Port-channel  Protocol    Ports
-----+-----+-----+-----
2      Po2(SU)       LACP        Et1/1(P)  Et1/2(P)

ALS2#

```

Figura 37. Enlace troncal Etherchannel Po2 en ALS2 & Etherchannel capa2 Po2 en ALS2

Los Port-channels en las interfaces F0/9 y fa0/10 utilizará PAgP.

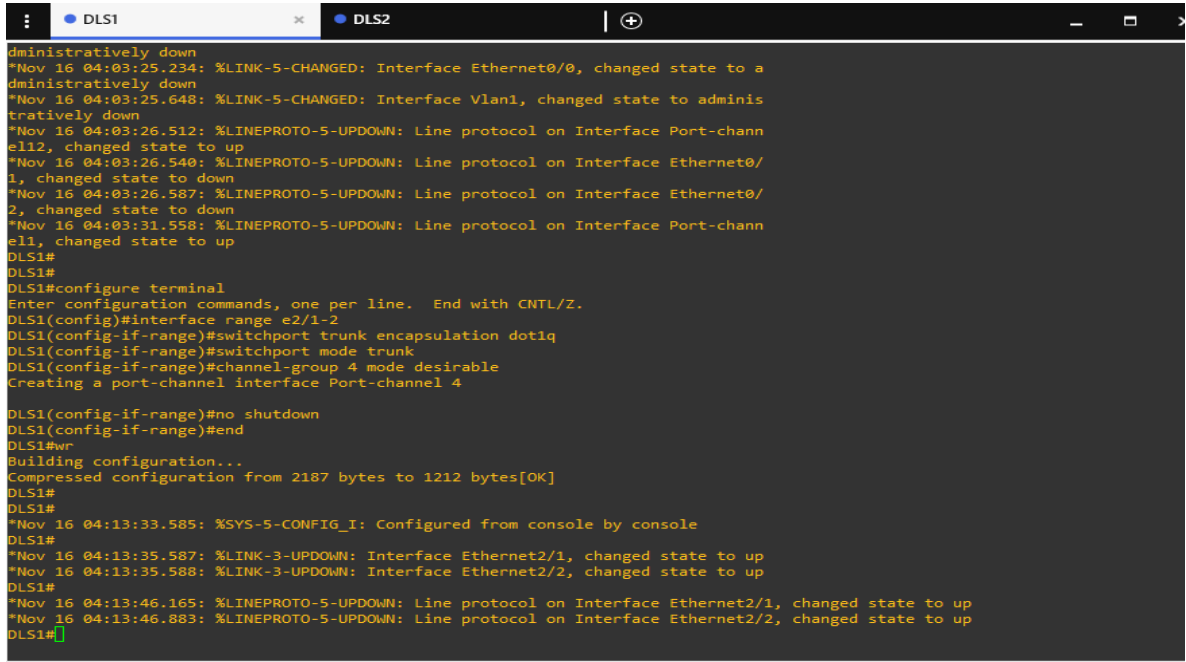

```
administratively down
*Nov 16 04:03:25.234: %LINK-5-CHANGED: Interface Ethernet0/0, changed state to a
administratively down
*Nov 16 04:03:25.648: %LINK-5-CHANGED: Interface Vlan1, changed state to adminis
tratively down
*Nov 16 04:03:26.512: %LINEPROTO-5-UPDOWN: Line protocol on Interface Port-chann
el12, changed state to up
*Nov 16 04:03:26.540: %LINEPROTO-5-UPDOWN: Line protocol on Interface Ethernet0/
1, changed state to down
*Nov 16 04:03:26.587: %LINEPROTO-5-UPDOWN: Line protocol on Interface Ethernet0/
2, changed state to down
*Nov 16 04:03:31.558: %LINEPROTO-5-UPDOWN: Line protocol on Interface Port-chann
el11, changed state to up
DLS1#
DLS1#
DLS1#configure terminal
Enter configuration commands, one per line. End with CNTL/Z.
DLS1(config)#interface range e2/1-2
DLS1(config-if-range)#switchport trunk encapsulation dot1q
DLS1(config-if-range)#switchport mode trunk
DLS1(config-if-range)#channel-group 4 mode desirable
Creating a port-channel interface Port-channel 4

DLS1(config-if-range)#no shutdown
DLS1(config-if-range)#end
DLS1#wr
Building configuration...
Compressed configuration from 2187 bytes to 1212 bytes[OK]
DLS1#
DLS1#
*Nov 16 04:13:33.585: %SYS-5-CONFIG_I: Configured from console by console
DLS1#
*Nov 16 04:13:35.587: %LINK-3-UPDOWN: Interface Ethernet2/1, changed state to up
*Nov 16 04:13:35.588: %LINK-3-UPDOWN: Interface Ethernet2/2, changed state to up
DLS1#
*Nov 16 04:13:46.165: %LINEPROTO-5-UPDOWN: Line protocol on Interface Ethernet2/1, changed state to up
*Nov 16 04:13:46.883: %LINEPROTO-5-UPDOWN: Line protocol on Interface Ethernet2/2, changed state to up
DLS1#
```

Figura 38. Enlace troncal Etherchannel Po4 en DLS1

```
DLS1
DLS2
DLS2#
administratively down
*Nov 16 04:03:25.252: %LINK-5-CHANGED: Interface Ethernet0/3, changed state to a
administratively down
*Nov 16 04:03:25.252: %LINK-5-CHANGED: Interface Ethernet0/0, changed state to a
administratively down
*Nov 16 04:03:25.669: %LINK-5-CHANGED: Interface Vlan1, changed state to adminis
tratively down
*Nov 16 04:03:26.537: %LINEPROTO-5-UPDOWN: Line protocol on Interface Port-chann
el12, changed state to up
*Nov 16 04:03:26.565: %LINEPROTO-5-UPDOWN: Line protocol on Interface Ethernet0/
1, changed state to down
*Nov 16 04:03:26.601: %LINEPROTO-5-UPDOWN: Line protocol on Interface Ethernet0/
2, changed state to down
*Nov 16 04:03:31.583: %LINEPROTO-5-UPDOWN: Line protocol on Interface Port-chann
el2, changed state to up
DLS2#
DLS2#configure terminal
Enter configuration commands, one per line. End with CNTL/Z.
DLS2(config)#interface range e2/1-2
DLS2(config-if-range)#switchport trunk encapsulation dot1q
DLS2(config-if-range)#switchport mode trunk
DLS2(config-if-range)#channel-group 3 mode desirable
Creating a port-channel interface Port-channel 3

DLS2(config-if-range)#no shutdown
DLS2(config-if-range)#end
DLS2#wr
Building configuration...
Compressed configuration from 2187 bytes to 1209 bytes[OK]
DLS2#
*Nov 16 04:13:44.274: %SYS-5-CONFIG_I: Configured from console by console
DLS2#
*Nov 16 04:13:46.277: %LINK-3-UPDOWN: Interface Ethernet2/1, changed state to up
*Nov 16 04:13:46.277: %LINK-3-UPDOWN: Interface Ethernet2/2, changed state to up
DLS2#
*Nov 16 04:13:56.920: %LINEPROTO-5-UPDOWN: Line protocol on Interface Ethernet2/2, changed state to up
*Nov 16 04:13:57.328: %LINEPROTO-5-UPDOWN: Line protocol on Interface Ethernet2/1, changed state to up
DLS2#
```

Figura 39. Enlace troncal Etherchannel Po3 en DLS2

```
DLS1
DLS2
ALS1
ALS2
*Nov 16 04:03:25.219: %LINK-5-CHANGED: Interface Ethernet1/3, changed state to a
administratively down
*Nov 16 04:03:25.232: %LINK-5-CHANGED: Interface Ethernet1/0, changed state to a
administratively down
*Nov 16 04:03:25.232: %LINK-5-CHANGED: Interface Ethernet0/3, changed state to a
administratively down
*Nov 16 04:03:25.232: %LINK-5-CHANGED: Interface Ethernet0/2, changed state to a
administratively down
*Nov 16 04:03:25.232: %LINK-5-CHANGED: Interface Ethernet0/1, changed state to a
administratively down
*Nov 16 04:03:25.232: %LINK-5-CHANGED: Interface Ethernet0/0, changed state to a
administratively down
*Nov 16 04:03:25.567: %LINK-5-CHANGED: Interface Vlan1, changed state to adminis
tratively down
*Nov 16 04:03:31.558: %LINEPROTO-5-UPDOWN: Line protocol on Interface Port-chann
el1, changed state to up
ALS1#
ALS1#
ALS1#configure terminal
Enter configuration commands, one per line. End with CNTL/Z.
ALS1(config)#interface range e1/1-2
ALS1(config-if-range)#switchport trunk encapsulation dot1q
ALS1(config-if-range)#switchport mode trunk
ALS1(config-if-range)#channel-group 3 mode desirable
Creating a port-channel interface Port-channel 3

ALS1(config-if-range)#no shutdown
ALS1(config-if-range)#end
ALS1#wr
Building configuration...
Compressed configuration from 1800 bytes to 1028 bytes[OK]
ALS1#
ALS1#
*Nov 16 04:18:28.246: %SYS-5-CONFIG_I: Configured from console by console
ALS1#
*Nov 16 04:18:30.244: %LINK-3-UPDOWN: Interface Port-channel1, changed state to down
*Nov 16 04:18:31.252: %LINEPROTO-5-UPDOWN: Line protocol on Interface Port-chann
el1, changed state to down
ALS1#
```

Figura 40. Enlace troncal Etherchannel Po3 en ALS1

```
ALS2#
ALS2#configure terminal
Enter configuration commands, one per line. End with CNTL/Z.
ALS2(config)#interface range e1/1-2
ALS2(config-if-range)#switchport trunk encapsulation dot1q
ALS2(config-if-range)#switchport mode trunk
ALS2(config-if-range)#channel-group 4 mode desirable
Creating a port-channel interface Port-channel 4

ALS2(config-if-range)#no shutdown
ALS2(config-if-range)#end
ALS2#wr
Building configuration...
Compressed configuration from 1800 bytes to 1033 bytes[OK]
ALS2#
ALS2#
*Nov 16 04:18:37.255: %SYS-5-CONFIG_I: Configured from console by console
ALS2#
*Nov 16 04:18:39.255: %LINK-3-UPDOWN: Interface Port-channel2, changed state to down
*Nov 16 04:18:40.259: %LINEPROTO-5-UPDOWN: Line protocol on Interface Port-channel2, changed state to down
ALS2#
```

Figura 41. Enlace troncal Etherchannel Po4 en ALS2

Con los comandos show interfaces trunk y show etherchannel summary, verificamos configuración enlace troncal etherchannel en cada uno de los switch.

```
5 minute output rate 0 bits/sec, 0 packets/sec
0 packets input, 0 bytes, 0 no buffer
Received 0 broadcasts (0 IP multicasts)
0 runts, 0 giants, 0 throttles
0 input errors, 0 CRC, 0 frame, 0 overrun, 0 ignored
0 packets output, 0 bytes, 0 underruns
0 output errors, 0 interface resets
0 unknown protocol drops
0 output buffer failures, 0 output buffers swapped out
DLS1#
DLS1#show interfaces trunk

Port      Mode           Encapsulation  Status        Native vlan
Et1/1     on             802.1q         trunking     1
Et1/2     on             802.1q         trunking     1
Et2/1     on             802.1q         trunking     1
Et2/2     on             802.1q         trunking     1

Port      Vlans allowed on trunk
Et1/1     none
Et1/2     none
Et2/1     1-4094
Et2/2     1-4094

Port      Vlans allowed and active in management domain
Et1/1     none
Et1/2     none
Et2/1     1
Et2/2     1

Port      Vlans in spanning tree forwarding state and not pruned
Et1/1     none
Et1/2     none
Et2/1     1

Port      Vlans in spanning tree forwarding state and not pruned
Et2/2     1
DLS1#
```

Figura 42. Enlace troncal Etherchannel Po4 en DLS1

```

DLS1
DLS2
ALS1
ALS2

Flags: D - down          P - bundled in port-channel
       I - stand-alone  s - suspended
       H - Hot-standby (LACP only)
       R - Layer3      S - Layer2
       U - in use      N - not in use, no aggregation
       f - failed to allocate aggregator

       M - not in use, minimum links not met
       m - not in use, port not aggregated due to minimum links not met
       u - unsuitable for bundling
       w - waiting to be aggregated
       d - default port

       A - formed by Auto LAG

Number of channel-groups in use: 3
Number of aggregators:          3

Group  Port-channel  Protocol    Ports
-----+-----+-----+-----+-----
 1     Po1(SD)       LACP        Et1/1(s)   Et1/2(s)
 4     Po4(SD)       PAgP        Et2/1(I)   Et2/2(I)
12     Po12(RD)      LACP        Et0/1(D)   Et0/2(D)

DLS1#

```

Figura 43. Etherchannel capa2 Po4 en DLS1

```

DLS1
DLS2
ALS1
ALS2

*Nov 16 04:18:39.245: %LINK-3-UPDOWN: Interface Port-channel2, changed state to down
*Nov 16 04:18:40.245: %LINEPROTO-5-UPDOWN: Line protocol on Interface Port-channel2, changed state to down
DLS2#
*Nov 16 04:18:42.595: %EC-5-L3DONTBNDL2: Et1/1 suspended: LACP currently not enabled on the remote port.
*Nov 16 04:18:42.860: %EC-5-L3DONTBNDL2: Et1/2 suspended: LACP currently not enabled on the remote port.
DLS2#
*Nov 16 04:20:00.596: %EC-5-L3DONTBNDL2: Et1/1 suspended: LACP currently not enabled on the remote port.
DLS2#
*Nov 16 04:20:12.069: %EC-5-L3DONTBNDL2: Et1/2 suspended: LACP currently not enabled on the remote port.
DLS2#
DLS2#show interfaces trunk

Port      Mode          Encapsulation  Status        Native vlan
Et1/1     on            802.1q         trunking      1
Et1/2     on            802.1q         trunking      1
Et2/1     on            802.1q         trunking      1
Et2/2     on            802.1q         trunking      1

Port      Vlans allowed on trunk
Et1/1     none
Et1/2     none
Et2/1     1-4094
Et2/2     1-4094

Port      Vlans allowed and active in management domain
Et1/1     none
Et1/2     none
Et2/1     1
Et2/2     1

Port      Vlans in spanning tree forwarding state and not pruned
Et1/1     none
Et1/2     none
Et2/1     1

Port      Vlans in spanning tree forwarding state and not pruned
Et2/2     1
DLS2#

```

Figura 44. Enlace troncal Etherchannel Po3 en DLS2

```

DLS2#show etherchannel summary
Flags: D - down          P - bundled in port-channel
       I - stand-alone  S - suspended
       H - Hot-standby (LACP only)
       R - Layer3       S - Layer2
       U - in use       N - not in use, no aggregation
       f - failed to allocate aggregator

       M - not in use, minimum links not met
       m - not in use, port not aggregated due to minimum links not met
       u - unsuitable for bundling
       w - waiting to be aggregated
       d - default port

       A - formed by Auto LAG

Number of channel-groups in use: 3
Number of aggregators:          3

Group  Port-channel  Protocol    Ports
-----+-----+-----+-----
 2     Po2(SD)       LACP        Et1/1(s)  Et1/2(s)
 3     Po3(SD)       PAGP        Et2/1(I)  Et2/2(I)
12     Po12(RD)      LACP        Et0/1(D)  Et0/2(D)

DLS2#

```

Figura 45. Etherchannel capa2 Po3 en DLS2

```

ALS1#configure terminal
Enter configuration commands, one per line. End with CNTL/Z.
ALS1(config)#interface range e1/1-2
ALS1(config-if-range)#switchport trunk encapsulation dot1q
ALS1(config-if-range)#switchport mode trunk
ALS1(config-if-range)#channel-group 3 mode desirable
Creating a port-channel interface Port-channel 3

ALS1(config-if-range)#no shutdown
ALS1(config-if-range)#end
ALS1#wr
Building configuration...
Compressed configuration from 1800 bytes to 1028 bytes[OK]
ALS1#
ALS1#
*Nov 16 04:18:28.246: %SYS-5-CONFIG_I: Configured from console by console
ALS1#
*Nov 16 04:18:30.244: %LINK-3-UPDOWN: Interface Port-channel1, changed state to down
*Nov 16 04:18:31.252: %LINEPROTO-5-UPDOWN: Line protocol on Interface Port-channel1, changed state to down
ALS1#
ALS1#show interfaces trunk

Port        Mode           Encapsulation  Status        Native vlan
Et1/1       on             802.1q         trunking      1
Et1/2       on             802.1q         trunking      1

Port        Vlans allowed on trunk
Et1/1       1-4094
Et1/2       1-4094

Port        Vlans allowed and active in management domain
Et1/1       1
Et1/2       1

Port        Vlans in spanning tree forwarding state and not pruned
Et1/1       1
Et1/2       1
ALS1#

```

Figura 46. Enlace troncal Etherchannel Po3 en ALS1

```

ALS1#show etherchannel summary
Flags: D - down          P - bundled in port-channel
       I - stand-alone  S - suspended
       H - Hot-standby (LACP only)
       R - Layer3       S - Layer2
       U - in use       N - not in use, no aggregation
       f - failed to allocate aggregator

       M - not in use, minimum links not met
       m - not in use, port not aggregated due to minimum links not met
       u - unsuitable for bundling
       w - waiting to be aggregated
       d - default port

       A - formed by Auto LAG

Number of channel-groups in use: 2
Number of aggregators:          2

Group  Port-channel  Protocol    Ports
-----
1      Po1(SD)         -           Et1/1(I)  Et1/2(I)
3      Po3(SD)         PAgP       Et1/1(I)  Et1/2(I)
ALS1#

```

Figura 47. Etherchannel capa2 Po3 en ALS1

```

ALS2#configure terminal
Enter configuration commands, one per line. End with CNTL/Z.
ALS2(config)#interface range e1/1-2
ALS2(config-if-range)#switchport trunk encapsulation dot1q
ALS2(config-if-range)#switchport mode trunk
ALS2(config-if-range)#channel-group 4 mode desirable
Creating a port-channel interface Port-channel 4

ALS2(config-if-range)#no shutdown
ALS2(config-if-range)#end
ALS2#wr
Building configuration...
Compressed configuration from 1800 bytes to 1033 bytes[OK]
ALS2#
ALS2#
*Nov 16 04:18:37.255: %SYS-5-CONFIG_I: Configured from console by console
ALS2#
*Nov 16 04:18:39.255: %LINK-3-UPDOWN: Interface Port-channel2, changed state to down
*Nov 16 04:18:40.259: %LINEPROTO-5-UPDOWN: Line protocol on Interface Port-channel2, changed state to down
ALS2#
ALS2#show interfaces trunk

Port      Mode           Encapsulation  Status        Native vlan
Et1/1    on             802.1q         trunking     1
Et1/2    on             802.1q         trunking     1

Port      Vlans allowed on trunk
Et1/1    1-4094
Et1/2    1-4094

Port      Vlans allowed and active in management domain
Et1/1    1
Et1/2    1

Port      Vlans in spanning tree forwarding state and not pruned
Et1/1    1
Et1/2    1
ALS2#

```

Figura 48. Enlace troncal Etherchannel Po4 en ALS2

```
Port      Vlans allowed on trunk
Et1/1    1-4094
Et1/2    1-4094

Port      Vlans allowed and active in management domain
Et1/1    1
Et1/2    1

Port      Vlans in spanning tree forwarding state and not pruned
Et1/1    1
Et1/2    1
ALS2#show etherchannel summary
Flags: D - down          P - bundled in port-channel
       I - stand-alone   s - suspended
       H - Hot-standby (LACP only)
       R - Layer3        S - Layer2
       U - in use       N - not in use, no aggregation
       f - failed to allocate aggregator

       M - not in use, minimum links not met
       m - not in use, port not aggregated due to minimum links not met
       u - unsuitable for bundling
       w - waiting to be aggregated
       d - default port

       A - formed by Auto LAG

Number of channel-groups in use: 2
Number of aggregators:          2

Group  Port-channel  Protocol    Ports
-----+-----+-----+-----
2      Po2(SD)        -           Et1/1(I)  Et1/2(I)
4      Po4(SD)        PAgP       Et1/1(I)  Et1/2(I)
ALS2#
```

Figura 49. Etherchannel capa2 Po4 en ALS2

Todos los puertos troncales serán asignados a la VLAN 500 como la VLAN nativa.

Para el switch DLS1, se realizara la configuración de la vlan nativa (500), en los puertos troncales Eth1/1-2,Eth2/1-2, que van hacia ALS1 y 2. Sin embargo no se aplicara esta configuración Eth0/1-2 que van a DLS2, puesto que estos fueron seteados, como puertos de capa 3.

```
*Nov 16 14:33:50.384: %SYS-5-CONFIG_I: Configured from console by console
DLS1#
DLS1#
DLS1#
DLS1#configure terminal
Enter configuration commands, one per line. End with CNTL/Z.
DLS1(config)#vlan 500
DLS1(config-vlan)#name nativa
DLS1(config-vlan)#exit
DLS1(config)#interface range Eth1/1-2,Eth2/1-2
DLS1(config-if-range)#switchport trunk native vlan 500
DLS1(config-if-range)#exit
DLS1(config)#interface port-channel 1
DLS1(config-if)#switchport trunk native vlan 500
DLS1(config-if)#exit
DLS1(config)#interface port-channel 4
DLS1(config-if)#switchport trunk native vlan 500
DLS1(config-if)#end
DLS1#wr
*Nov 16 14:39:18.211: %EC-5-CANNOT_BUNDLE2: Et1/1 is not compatible with Et1/2 and will be suspended (native vlan of Et1/1 is 500, Et1/2 id 1)
*Nov 16 14:39:18.212: %EC-5-CANNOT_BUNDLE2: Et1/1 is not compatible with Et1/2 and will be suspended (native vlan of Et1/1 is 500, Et1/2 id 1)
*Nov 16 14:39:18.212: %EC-5-COMPATIBLE: Et1/1 is compatible with port-channel members
*Nov 16 14:39:18.214: %EC-5-CANNOT_BUNDLE2: Et2/1 is not compatible with Et2/2 and will be suspended (native vlan of Et2/1 is 500, Et2/2 id 1)
*Nov 16 14:39:18.227: %SYS-5-CONFIG_I: Configured from console by console
DLS1#wr
Building configuration...
Compressed configuration from 2391 bytes to 1277 bytes[OK]
DLS1#
*Nov 16 14:39:19.893: %EC-5-COMPATIBLE: Et2/1 is compatible with port-channel members
DLS1#
*Nov 16 14:39:26.087: %EC-5-L3DONTBNDL2: Et1/2 suspended: LACP currently not enabled on the remote port.
*Nov 16 14:39:26.461: %EC-5-L3DONTBNDL2: Et1/1 suspended: LACP currently not enabled on the remote port.
DLS1#
```

Figura 50. VLAN 500 seteada en puertos troncales sw DLS1

Para el switch DLS2, se realizara la configuración de la vlan nativa (500), en los puertos troncales Eth1/1-2,Eth2/1-2, que van hacia ALS1 y 2. Sin embargo no se aplicara esta configuración Eth0/1-2 que van a DLS2, puesto que estos fueron seteados, como puertos de capa 3.

```
DLS1
DLS2
DLS2#
*Nov 16 15:02:13.281: %CDP-4-NATIVE_VLAN_MISMATCH: Native VLAN mismatch discovered on Ethernet1/2 (500), with ALS2 Ethernet1/2 (1).
DLS2#
*Nov 16 15:02:16.125: %CDP-4-NATIVE_VLAN_MISMATCH: Native VLAN mismatch discovered on Ethernet1/1 (500), with ALS2 Ethernet1/1 (1).
DLS2#
*Nov 16 15:03:10.559: %CDP-4-NATIVE_VLAN_MISMATCH: Native VLAN mismatch discovered on Ethernet1/1 (500), with ALS2 Ethernet1/1 (1).
*Nov 16 15:03:11.612: %CDP-4-NATIVE_VLAN_MISMATCH: Native VLAN mismatch discovered on Ethernet1/2 (500), with ALS2 Ethernet1/2 (1).
DLS2#
DLS2#
DLS2#
DLS2#
DLS2#configure terminal
Enter configuration commands, one per line. End with CNTL/Z.
DLS2(config)#vlan 500
DLS2(config-vlan)#name nativa
DLS2(config-vlan)#exit
DLS2(config)#interface range Eth1/1-2,Eth2/1-2
DLS2(config-if-range)#switchport trunk native vlan 500
DLS2(config-if-range)#exit
DLS2(config)#interface port-channel 2
DLS2(config-if)#switchport trunk native vlan 500
DLS2(config-if)#exit
DLS2(config)#interface port-channel 3
DLS2(config-if)#switchport trunk native vlan 500
DLS2(config-if)#end
DLS2#wr
Building configuration...
Compressed configuration from 2511 bytes to 1321 bytes[OK]
DLS2#
*Nov 16 15:03:33.219: %SYS-5-CONFIG_I: Configured from console by console
DLS2#
DLS2#
DLS2#
DLS2#
```

Figura 51. VLAN 500 seteada en puertos troncales sw DLS2

```

DLS1
DLS2
ALS1
*Nov 16 15:03:34.457: %CDP-4-NATIVE_VLAN_MISMATCH: Native VLAN mismatch discover
ed on Ethernet1/2 (1), with DLS1 Ethernet1/2 (500).
*Nov 16 15:04:12.375: %CDP-4-NATIVE_VLAN_MISMATCH: Native VLAN mismatch discover
ed on Ethernet1/1 (1), with DLS1 Ethernet1/1 (500).
*Nov 16 15:04:34.207: %CDP-4-NATIVE_VLAN_MISMATCH: Native VLAN mismatch discover
ed on Ethernet1/2 (1), with DLS1 Ethernet1/2 (500).
*Nov 16 15:05:09.680: %CDP-4-NATIVE_VLAN_MISMATCH: Native VLAN mismatch discover
ed on Ethernet1/1 (1), with DLS1 Ethernet1/1 (500).
ALS1#
ALS1#
ALS1#
ALS1#
ALS1#
ALS1#configure terminal
Enter configuration commands, one per line. End with CNTL/Z.
ALS1(config)#vlan 500
ALS1(config-vlan)#name nativa
ALS1(config-vlan)#exit
ALS1(config)#interface range Eth1/1-2,Eth2/1-2
ALS1(config-if-range)#switchport trunk native vlan 500
ALS1(config-if-range)#exit
ALS1(config)#interface port-channel 1
ALS1(config-if)#switchport trunk native vlan 500
ALS1(config-if)#exit
ALS1(config)#interface port-channel 3
ALS1(config-if)#switchport trunk native vlan 500
ALS1(config-if)#end
ALS1#wr
Building configuration...
Compressed configuration from 2004 bytes to 1113 bytes[OK]
ALS1#
*Nov 16 15:05:28.793: %EC-5-CANNOT_BUNDLE2: Et1/1 is not compatible with Et1/2 and will be suspended (native vlan of Et1/1 i
s 500, Et1/2 id 1)
*Nov 16 15:05:28.804: %SYS-5-CONFIG_I: Configured from console by console
ALS1#
ALS1#
*Nov 16 15:05:30.872: %EC-5-COMPATIBLE: Et1/1 is compatible with port-channel members
ALS1#
solarwinds | Solar-PuTTY free tool | © 2019 SolarWinds Worldwide, LLC. All rights reserved.
```

Figura 52. VLAN 500 seteada en puertos troncales sw ALS1

```

DLS1
DLS2
ALS1
ALS2
ed on Ethernet1/2 (1), with DLS2 Ethernet1/2 (500).
*Nov 16 15:05:30.416: %CDP-4-NATIVE_VLAN_MISMATCH: Native VLAN mismatch discover
ed on Ethernet1/1 (1), with DLS2 Ethernet1/1 (500).
*Nov 16 15:06:21.887: %CDP-4-NATIVE_VLAN_MISMATCH: Native VLAN mismatch discover
ed on Ethernet1/2 (1), with DLS2 Ethernet1/2 (500).
*Nov 16 15:06:25.239: %CDP-4-NATIVE_VLAN_MISMATCH: Native VLAN mismatch discover
ed on Ethernet1/1 (1), with DLS2 Ethernet1/1 (500).
ALS2#
ALS2#
ALS2#
ALS2#
*Nov 16 15:07:11.621: %CDP-4-NATIVE_VLAN_MISMATCH: Native VLAN mismatch discovered on Ethernet1/2 (1), with DLS2 Ethernet1/2
(500).
ALS2#configure terminal
Enter configuration commands, one per line. End with CNTL/Z.
ALS2(config)#vlan 500
ALS2(config-vlan)#name nativa
ALS2(config-vlan)#exit
ALS2(config)#interface range Eth1/1-2,Eth2/1-2
ALS2(config-if-range)#switchport trunk native vlan 500
ALS2(config-if-range)#exit
ALS2(config)#interface port-channel 2
ALS2(config-if)#switchport trunk native vlan 500
ALS2(config-if)#exit
ALS2(config)#interface port-channel 4
ALS2(config-if)#switchport trunk native vlan 500
ALS2(config-if)#end
ALS2#wr
Building configuration...
Compressed configuration from 2004 bytes to 1105 bytes[OK]
ALS2#
*Nov 16 15:07:14.964: %EC-5-CANNOT_BUNDLE2: Et1/1 is not compatible with Et1/2 and will be suspended (native vlan of Et1/1 i
s 500, Et1/2 id 1)
*Nov 16 15:07:14.973: %SYS-5-CONFIG_I: Configured from console by console
ALS2#
ALS2#
*Nov 16 15:07:20.961: %EC-5-COMPATIBLE: Et1/1 is compatible with port-channel members
ALS2#
solarwinds | Solar-PuTTY free tool | © 2019 SolarWinds Worldwide, LLC. All rights reserved.
```

Figura 53. VLAN 500 seteada en puertos troncales sw ALS2

- c. Configurar DLS1, ALS1, y ALS2 para utilizar VTP versión 3, utilizar el nombre de dominio CISCO con la contraseña ccnp321, configurar DLS1 como servidor principal para las VLAN, configurar ALS1 y ALS2 como clientes VTP.

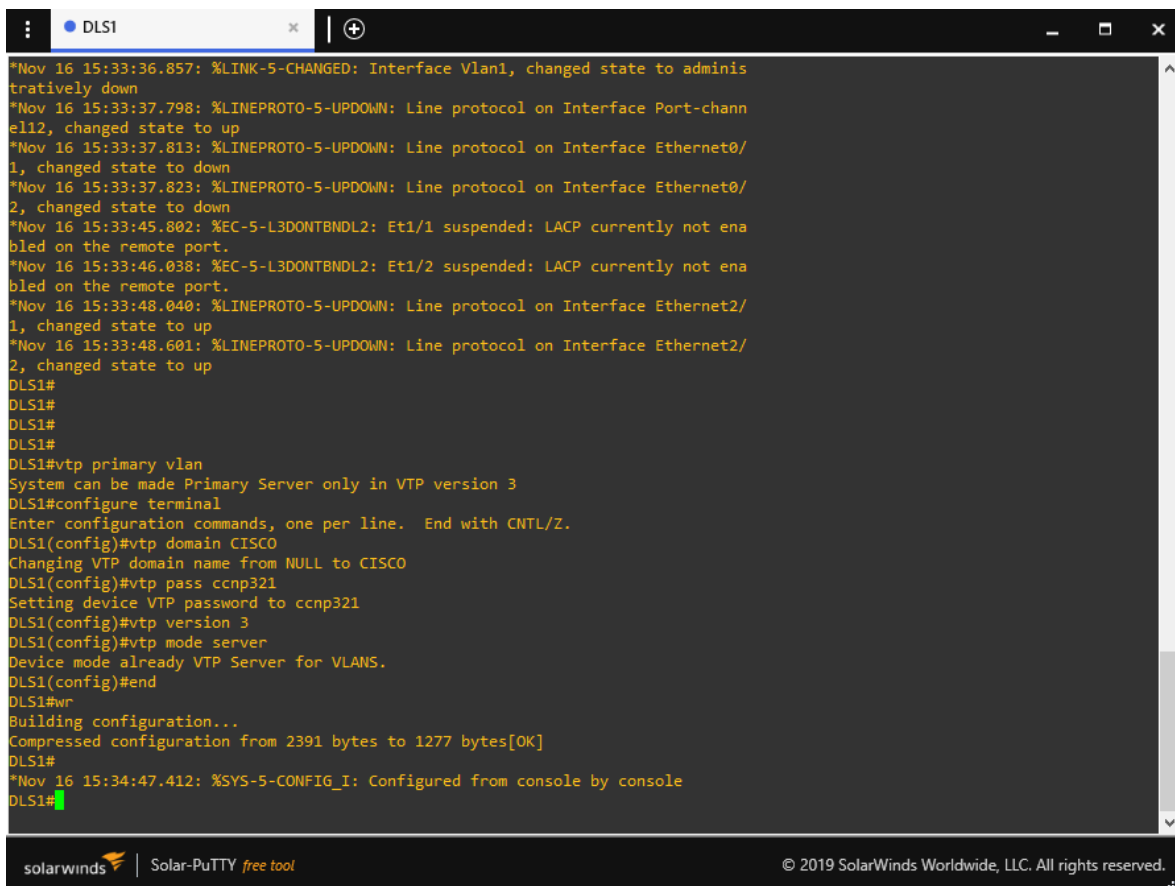

```
*Nov 16 15:33:36.857: %LINK-5-CHANGED: Interface Vlan1, changed state to administratively down
*Nov 16 15:33:37.798: %LINEPROTO-5-UPDOWN: Line protocol on Interface Port-channel112, changed state to up
*Nov 16 15:33:37.813: %LINEPROTO-5-UPDOWN: Line protocol on Interface Ethernet0/1, changed state to down
*Nov 16 15:33:37.823: %LINEPROTO-5-UPDOWN: Line protocol on Interface Ethernet0/2, changed state to down
*Nov 16 15:33:45.802: %EC-5-L3DONTBNDL2: Et1/1 suspended: LACP currently not enabled on the remote port.
*Nov 16 15:33:46.038: %EC-5-L3DONTBNDL2: Et1/2 suspended: LACP currently not enabled on the remote port.
*Nov 16 15:33:48.040: %LINEPROTO-5-UPDOWN: Line protocol on Interface Ethernet2/1, changed state to up
*Nov 16 15:33:48.601: %LINEPROTO-5-UPDOWN: Line protocol on Interface Ethernet2/2, changed state to up
DLS1#
DLS1#
DLS1#
DLS1#
DLS1#vtp primary vlan
System can be made Primary Server only in VTP version 3
DLS1#configure terminal
Enter configuration commands, one per line. End with CNTL/Z.
DLS1(config)#vtp domain CISCO
Changing VTP domain name from NULL to CISCO
DLS1(config)#vtp pass ccnp321
Setting device VTP password to ccnp321
DLS1(config)#vtp version 3
DLS1(config)#vtp mode server
Device mode already VTP Server for VLANs.
DLS1(config)#end
DLS1#wr
Building configuration...
Compressed configuration from 2391 bytes to 1277 bytes[OK]
DLS1#
*Nov 16 15:34:47.412: %SYS-5-CONFIG_I: Configured from console by console
DLS1#
```

Figura 54. Configuración VTP en DLS1

```
administratively down
*Nov 16 15:33:36.710: %LINK-5-CHANGED: Interface Ethernet2/1, changed state to a
administratively down
*Nov 16 15:33:36.710: %LINK-5-CHANGED: Interface Ethernet2/0, changed state to a
administratively down
*Nov 16 15:33:36.710: %LINK-5-CHANGED: Interface Ethernet1/3, changed state to a
administratively down
*Nov 16 15:33:36.710: %LINK-5-CHANGED: Interface Ethernet1/0, changed state to a
administratively down
*Nov 16 15:33:36.710: %LINK-5-CHANGED: Interface Ethernet0/3, changed state to a
administratively down
*Nov 16 15:33:36.710: %LINK-5-CHANGED: Interface Ethernet0/2, changed state to a
administratively down
*Nov 16 15:33:36.710: %LINK-5-CHANGED: Interface Ethernet0/1, changed state to a
administratively down
*Nov 16 15:33:36.710: %LINK-5-CHANGED: Interface Ethernet0/0, changed state to a
administratively down
*Nov 16 15:33:36.818: %LINK-5-CHANGED: Interface Vlan1, changed state to adminis
tratively down
ALS1#
ALS1#
ALS1#configure terminal
Enter configuration commands, one per line. End with CNTL/Z.
ALS1(config)#vtp domain CISCO
Changing VTP domain name from NULL to CISCO
ALS1(config)#vtp pass ccnp321
Setting device VTP password to ccnp321
ALS1(config)#vtp version 3
ALS1(config)#vtp mode client
Setting device to VTP Client mode for VLANS.
ALS1(config)#end
ALS1#wr
Building configuration...
Compressed configuration from 2004 bytes to 1114 bytes[OK]
ALS1#
*Nov 16 15:39:24.820: %SYS-5-CONFIG_I: Configured from console by console
ALS1#
ALS1#
ALS1#
```

Figura 55. Configuración VTP modo cliente en ALS1

```
administratively down
*Nov 16 15:33:36.721: %LINK-5-CHANGED: Interface Ethernet2/1, changed state to a
administratively down
*Nov 16 15:33:36.721: %LINK-5-CHANGED: Interface Ethernet2/0, changed state to a
administratively down
*Nov 16 15:33:36.721: %LINK-5-CHANGED: Interface Ethernet1/3, changed state to a
administratively down
*Nov 16 15:33:36.725: %LINK-5-CHANGED: Interface Ethernet1/0, changed state to a
administratively down
*Nov 16 15:33:36.725: %LINK-5-CHANGED: Interface Ethernet0/3, changed state to a
administratively down
*Nov 16 15:33:36.725: %LINK-5-CHANGED: Interface Ethernet0/2, changed state to a
administratively down
*Nov 16 15:33:36.725: %LINK-5-CHANGED: Interface Ethernet0/1, changed state to a
administratively down
*Nov 16 15:33:36.725: %LINK-5-CHANGED: Interface Ethernet0/0, changed state to a
administratively down
*Nov 16 15:33:36.840: %LINK-5-CHANGED: Interface Vlan1, changed state to adminis
tratively down
ALS2#
ALS2#
ALS2#configure terminal
Enter configuration commands, one per line. End with CNTL/Z.
ALS2(config)#vtp domain CISCO
Changing VTP domain name from NULL to CISCO
ALS2(config)#vtp pass ccnp321
Setting device VTP password to ccnp321
ALS2(config)#vtp version 3
ALS2(config)#vtp mode client
Setting device to VTP Client mode for VLANS.
ALS2(config)#end
ALS2#wr
Building configuration...
Compressed configuration from 2004 bytes to 1105 bytes[OK]
ALS2#
ALS2#
*Nov 16 15:41:04.022: %SYS-5-CONFIG_I: Configured from console by console
ALS2#
```

Figura 56. Configuración VTP modo cliente en ALS2

Una vez se configura VTP versión 3, en los switches DLS1, ALS1 y ALS2, se comprueba configuración en cada uno.

```
VTP Version capable      : 1 to 3
VTP version running     : 3
VTP Domain Name         : CISCO
VTP Pruning Mode        : Disabled
VTP Traps Generation    : Disabled
Device ID               : aabb.cc80.0100

Feature VLAN:
-----
VTP Operating Mode      : Server
Number of existing VLANs : 6
Number of existing extended VLANs : 0
Maximum VLANs supported locally : 4096
Configuration Revision  : 0
Primary ID              : 0000.0000.0000
Primary Description     :
MD5 digest              :

Feature MST:
-----
VTP Operating Mode      : Transparent

Feature UNKNOWN:
-----
VTP Operating Mode      : Transparent

DLS1#
```

Figura 57. Estado configuración VTP en DLS1

```
ALS1#show vtp status
VTP Version capable      : 1 to 3
VTP version running     : 3
VTP Domain Name         : CISCO
VTP Pruning Mode        : Disabled
VTP Traps Generation    : Disabled
Device ID               : aabb.cc80.0300

Feature VLAN:
-----
VTP Operating Mode      : Client
Number of existing VLANs : 6
Number of existing extended VLANs : 0
Maximum VLANs supported locally : 4096
Configuration Revision  : 0
Primary ID              : 0000.0000.0000
Primary Description     :
MD5 digest              :

Feature MST:
-----
VTP Operating Mode      : Transparent

Feature UNKNOWN:
-----
VTP Operating Mode      : Transparent

ALS1#
```

Figura 58. Estado Configuración VTP en ALS1

```
ALS2#
ALS2#show vtp status
VTP Version capable      : 1 to 3
VTP version running     : 3
VTP Domain Name         : CISCO
VTP Pruning Mode        : Disabled
VTP Traps Generation    : Disabled
Device ID               : aabb.cc80.0400

Feature VLAN:
-----
VTP Operating Mode      : Client
Number of existing VLANs : 6
Number of existing extended VLANs : 0
Maximum VLANs supported locally : 4096
Configuration Revision  : 0
Primary ID              : 0000.0000.0000
Primary Description     :
MD5 digest              :

Feature MST:
-----
VTP Operating Mode      : Transparent

Feature UNKNOWN:
-----
VTP Operating Mode      : Transparent

ALS2#
```

Figura 59. Estado Configuración VTP en ALS2

d. Configurar en el servidor principal las siguientes VLAN:

Número de VLAN	Nombre de VLAN	Número de VLAN	Nombre de VLAN
500	NATIVA	434	PROVEEDORES
12	ADMON	123	SEGUROS
234	CLIENTES	1010	VENTAS
1111	MULTIMEDIA	3456	PERSONAL

Tabla 1. Configuración de VLANs

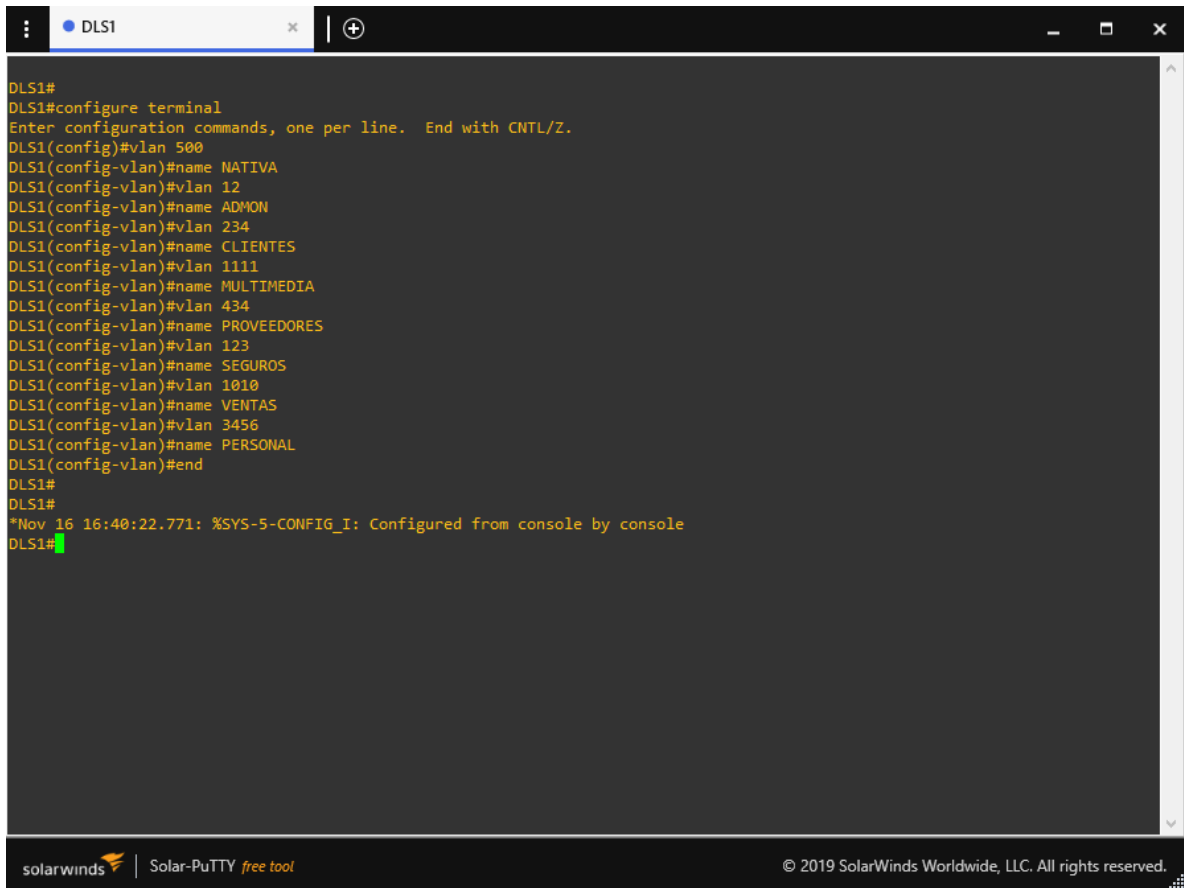

```
DLS1#
DLS1#configure terminal
Enter configuration commands, one per line. End with CNTL/Z.
DLS1(config)#vlan 500
DLS1(config-vlan)#name NATIVA
DLS1(config-vlan)#vlan 12
DLS1(config-vlan)#name ADMON
DLS1(config-vlan)#vlan 234
DLS1(config-vlan)#name CLIENTES
DLS1(config-vlan)#vlan 1111
DLS1(config-vlan)#name MULTIMEDIA
DLS1(config-vlan)#vlan 434
DLS1(config-vlan)#name PROVEEDORES
DLS1(config-vlan)#vlan 123
DLS1(config-vlan)#name SEGUROS
DLS1(config-vlan)#vlan 1010
DLS1(config-vlan)#name VENTAS
DLS1(config-vlan)#vlan 3456
DLS1(config-vlan)#name PERSONAL
DLS1(config-vlan)#end
DLS1#
DLS1#
*Nov 16 16:40:22.771: %SYS-5-CONFIG_I: Configured from console by console
DLS1#
```

Figura 60. Configuración VLANs en servidor principal

Con el comando show vlan verificaremos la configuración realizada en servidor principal, DLS1.

```

DLS1#show vlan

VLAN Name                Status    Ports
-----
1    default                 active    Et0/0, Et0/3, Et1/0, Et1/3
                                           Et2/0, Et2/3, Et3/0, Et3/1
                                           Et3/2, Et3/3

12   ADMON                   active
123  SEGUROS                 active
234  CLIENTES                active
434  PROVEEDORES             active
500  NATIVA                  active
1002 fddi-default            act/unsup
1003 trcrf-default         act/unsup
1004 fddinet-default        act/unsup
1005 trbrf-default        act/unsup
1010 VENTAS                 active
1111 MULTIMEDIA           active
3456 PERSONAL             active

VLAN Type  SAID      MTU   Parent RingNo BridgeNo Stp  BrdgMode Trans1 Trans2
-----
1    enet  100001   1500  -     -     -     -     -         0     0
12   enet  100012   1500  -     -     -     -     -         0     0

VLAN Type  SAID      MTU   Parent RingNo BridgeNo Stp  BrdgMode Trans1 Trans2
-----
123  enet  100123   1500  -     -     -     -     -         0     0
234  enet  100234   1500  -     -     -     -     -         0     0
434  enet  100434   1500  -     -     -     -     -         0     0
500  enet  100500   1500  -     -     -     -     -         0     0
1002 fddi  101002   1500  -     -     -     -     -         0     0
1003 trcrf 101003   4472  1005  3276  -     -     srb       0     0
1004 fdnet 101004   1500  -     -     -     -     -         0     0
1005 trbrf 101005   4472  -     -     15     -     ibm       0     0
1010 enet  101010   1500  -     -     -     -     -         0     0
1111 enet  101111   1500  -     -     -     -     -         0     0
3456 enet  103456   1500  -     -     -     -     -         0     0

VLAN AREHops STEHops Backup CRF
-----
1003 7          7          off

Remote SPAN VLANs
-----

Primary Secondary Type          Ports
-----

```

Figura 61. Estado configuración VLANs en servidor principal

e. En DLS1, suspender la VLAN 434.

```
DLS1#
DLS1#
DLS1#configure terminal
Enter configuration commands, one per line. End with CNTL/Z.
DLS1(config)#vlan 434
DLS1(config-vlan)#state suspend
DLS1(config-vlan)#end
DLS1#wr
Building configuration...
Compressed configuration from 2391 bytes to 1275 bytes[OK]
DLS1#
*Nov 16 16:48:55.023: %SYS-5-CONFIG_I: Configured from console by console
DLS1#
DLS1#
DLS1#
DLS1#
```

Figura 62. Configuración VLANs 434 suspendida en DLS1

```
DLS1#show vlan
VLAN Name                Status    Ports
-----
1    default                 active    Et0/0, Et0/3, Et1/0, Et1/3
                                           Et2/0, Et2/3, Et3/0, Et3/1
                                           Et3/2, Et3/3
12   ADMON                   active
123  SEGUROS                  active
234  CLIENTES                 active
434  PROVEEDORES             suspended
500  NATIVA                   active
1002 fddi-default             act/unsup
1003 trcrf-default          act/unsup
1004 fddinet-default         act/unsup
1005 trbrf-default          act/unsup
1010 VENTAS                  active
1111 MULTIMEDIA             active
3456 PERSONAL              active

VLAN Type SAID      MTU   Parent RingNo BridgeNo Stp  BrdgMode Trans1 Trans2
-----
1    enet  100001   1500  -     -     -     -     -     0     0
12   enet  100012   1500  -     -     -     -     -     0     0
123  enet  100123   1500  -     -     -     -     -     0     0

VLAN Type SAID      MTU   Parent RingNo BridgeNo Stp  BrdgMode Trans1 Trans2
-----
234  enet  100234   1500  -     -     -     -     -     0     0
434  enet  100434   1500  -     -     -     -     -     0     0
500  enet  100500   1500  -     -     -     -     -     0     0
1002 fddi  101002   1500  -     -     -     -     -     0     0
1003 trcrf 101003   4472  1005  3276  -     -     srb    0     0
1004 fdnet 101004   1500  -     -     -     -     -     0     0
1005 trbrf 101005   4472  -     -     15     -     ibm    0     0
1010 enet  101010   1500  -     -     -     -     -     0     0
1111 enet  101111   1500  -     -     -     -     -     0     0
3456 enet  103456   1500  -     -     -     -     -     0     0

VLAN AREHops STEHops Backup CRF
-----
1003 7         7         off

Remote SPAN VLANs
-----
```

Figura 63. Estado VLANs 434 suspendida en DLS1

- f. Configurar DLS2 en modo VTP transparente VTP utilizando VTP versión 2, y configurar en DLS2 las mismas VLAN que en DLS1.

```
DLS2#configure terminal
Enter configuration commands, one per line. End with CNTL/Z.
DLS2(config)#vtp domain CISCO
Changing VTP domain name from NULL to CISCO
DLS2(config)#vtp version 2
DLS2(config)#vtp mode trans
Setting device to VTP Transparent mode for VLANs.
DLS2(config)#vlan 500
DLS2(config-vlan)#name NATIVA
DLS2(config-vlan)#vlan 12
DLS2(config-vlan)#name ADMON
DLS2(config-vlan)#vlan 234
DLS2(config-vlan)#name CLIENTES
DLS2(config-vlan)#vlan 1111
DLS2(config-vlan)#name MULTIMEDIA
DLS2(config-vlan)#vlan 434
DLS2(config-vlan)#name PROVEEDORES
DLS2(config-vlan)#vlan 123
DLS2(config-vlan)#name SEGUROS
DLS2(config-vlan)#vlan 1010
DLS2(config-vlan)#name VENTAS
DLS2(config-vlan)#vlan 3456
DLS2(config-vlan)#name PERSONAL
DLS2(config-vlan)#end
DLS2#wr
Building configuration...
Compressed configuration from 2756 bytes to 1481 bytes[OK]
DLS2#
*Nov 16 17:00:11.990: %SYS-5-CONFIG_I: Configured from console by console
DLS2#
DLS2#
```

Figura 64. Configuración VLANs en DLS2

```
DLS2#show vlan
VLAN Name                Status    Ports
-----
1    default                 active    Et0/0, Et0/3, Et1/0, Et1/3
                                           Et2/0, Et2/3, Et3/0, Et3/1
                                           Et3/2, Et3/3
12   ADMON                   active
123  SEGUROS                 active
234  CLIENTES                active
434  PROVEEDORES             active
500  NATIVA                  active
1002 fddi-default            act/unsup
1003 trcrf-default         act/unsup
1004 fddinet-default        act/unsup
1005 trbrf-default         act/unsup
1010 VENTAS                  active
1111 MULTIMEDIA             active
3456 PERSONAL             active

VLAN Type SAID      MTU   Parent RingNo BridgeNo  Stp  BrdgMode Trans1 Trans2
----
1    enet 100001  1500  -     -     -        -   -         0      0
12   enet 100012  1500  -     -     -        -   -         0      0

VLAN Type SAID      MTU   Parent RingNo BridgeNo  Stp  BrdgMode Trans1 Trans2
----
123  enet 100123  1500  -     -     -        -   -         0      0
234  enet 100234  1500  -     -     -        -   -         0      0
434  enet 100434  1500  -     -     -        -   -         0      0
500  enet 100500  1500  -     -     -        -   -         0      0
1002 fddi 101002  1500  -     -     -        -   -         0      0
1003 trcrf 101003  4472  1005  3276  -        -   srb       0      0
1004 fdnet 101004  1500  -     -     -        -   -         0      0
1005 trbrf 101005  4472  -     -     15       -   -         0      0
1010 enet 101010  1500  -     -     -        -   -         0      0
1111 enet 101111  1500  -     -     -        -   -         0      0
3456 enet 103456  1500  -     -     -        -   -         0      0

VLAN AREHops STEHops Backup CRF
-----
1003 7          7          off

Remote SPAN VLANs
-----
```

Figura 65. Estado configuración VLANs en DLS2

g. Suspender VLAN 434 en DLS2.

```
DLS2#
DLS2#configure terminal
Enter configuration commands, one per line. End with CNTL/Z.
DLS2(config)#vlan 434
DLS2(config-vlan)#state suspend
DLS2(config-vlan)#end
DLS2#wr
*Nov 16 17:07:14.206: %SYS-5-CONFIG_I: Configured from console by console
DLS2#wr
Building configuration...
Compressed configuration from 2771 bytes to 1492 bytes[OK]
DLS2#
DLS2#
```

Figura 66. Configuración VLANs 434 suspendida en DLS2

```
DLS2#
DLS2#show vlan

VLAN Name                Status   Ports
-----
1    default                active  Et0/0, Et0/3, Et1/0, Et1/3
                                   Et2/0, Et2/3, Et3/0, Et3/1
                                   Et3/2, Et3/3
12   ADMON                  active
123  SEGUROS                active
234  CLIENTES               active
434  PROVEEDORES            suspended
500  NATIVA                 active
1002 fddi-default           act/unsup
1003 trcrf-default        act/unsup
1004 fddinet-default      act/unsup
1005 trbrf-default        act/unsup
1010 VENTAS                active
1111 MULTIMEDIA           active
3456 PERSONAL            active

VLAN Type  SAID      MTU   Parent  RingNo BridgeNo  Stp  BrdgMode  Trans1  Trans2
-----
1    enet  100001   1500   -       -       -   -         0       0
12   enet  100012   1500   -       -       -   -         0       0

VLAN Type  SAID      MTU   Parent  RingNo BridgeNo  Stp  BrdgMode  Trans1  Trans2
-----
123  enet  100123   1500   -       -       -   -         0       0
234  enet  100234   1500   -       -       -   -         0       0
434  enet  100434   1500   -       -       -   -         0       0
500  enet  100500   1500   -       -       -   -         0       0
1002 fddi  101002   1500   -       -       -   -         0       0
1003 trcrf 101003   4472  1005   3276   -       -   srb       0       0
1004 fdnet 101004   1500   -       -       -   -         0       0
1005 trbrf 101005   4472   -       -       15   -   ibm       0       0
1010 enet  101010   1500   -       -       -   -         0       0
1111 enet  101111   1500   -       -       -   -         0       0
3456 enet  103456   1500   -       -       -   -         0       0

VLAN AREHops STEHops Backup CRF
-----
1003 7         7         off

Remote SPAN VLANs
```

Figura 67. Estado VLANs en DLS2

i. En DLS2, crear VLAN 567 con el nombre de PRODUCCION. La VLAN de PRODUCCION no podrá estar disponible en cualquier otro Switch de la red.

```
DLS2#
DLS2#
DLS2#configure terminal
Enter configuration commands, one per line. End with CNTL/Z.
DLS2(config)#vlan 567
DLS2(config-vlan)#name PRODUCCION
DLS2(config-vlan)#private-vlan isolated
DLS2(config-vlan)#end
DLS2#wr
Building configuration...
Compressed configuration from 2823 bytes to 1519 bytes[OK]
DLS2#
*Nov 16 17:14:17.885: %SYS-5-CONFIG_I: Configured from console by console
DLS2#
DLS2#
```

Figura 68. Configuración VLANs 567 en DLS2

```
DLS2#show vlan
```

VLAN	Name	Status	Ports
1	default	active	Et0/0, Et0/3, Et1/0, Et1/3 Et2/0, Et2/3, Et3/0, Et3/1 Et3/2, Et3/3
12	ADMON	active	
123	SEGUROS	active	
234	CLIENTES	active	
434	PROVEEDORES	suspended	
500	NATIVA	active	
567	PRODUCCION	active	
1002	fddi-default	act/unsup	
1003	trcrf-default	act/unsup	
1004	fddinet-default	act/unsup	
1005	trbrf-default	act/unsup	
1010	VENTAS	active	
1111	MULTIMEDIA	active	
3456	PERSONAL	active	

VLAN	Type	SAID	MTU	Parent	RingNo	BridgeNo	Stp	BrdgMode	Trans1	Trans2
1	enet	100001	1500	-	-	-	-	-	0	0
12	enet	100012	1500	-	-	-	-	-	0	0
123	enet	100123	1500	-	-	-	-	-	0	0
234	enet	100234	1500	-	-	-	-	-	0	0
434	enet	100434	1500	-	-	-	-	-	0	0
500	enet	100500	1500	-	-	-	-	-	0	0
567	enet	100567	1500	-	-	-	-	-	0	0
1002	fddi	101002	1500	-	-	-	-	-	0	0
1003	trcrf	101003	4472	1005	3276	-	-	srb	0	0
1004	fdnet	101004	1500	-	-	15	-	ieee	0	0
1005	trbrf	101005	4472	-	-	-	-	ibm	0	0
1010	enet	101010	1500	-	-	-	-	-	0	0
1111	enet	101111	1500	-	-	-	-	-	0	0
3456	enet	103456	1500	-	-	-	-	-	0	0

VLAN	AREHops	STEHops	Backup	CRF
1003	7	7	off	

Figura 69. Estado configuración VLANs en DLS2

- h. Configurar DLS1 como Spanning tree root para las VLAN 1, 12, 434, 500, 1010, 1111 y 3456 y como raíz secundaria para las VLAN 123 y 234.

```

-----
123 enet 100123 1500 - - - - - 0 0
234 enet 100234 1500 - - - - - 0 0
434 enet 100434 1500 - - - - - 0 0
500 enet 100500 1500 - - - - - 0 0
1002 fddi 101002 1500 - - - - - 0 0
1003 trcrf 101003 4472 1005 3276 - - - srb 0 0
1004 fdnet 101004 1500 - - - - - ieee 0 0
1005 trbrf 101005 4472 - - - 15 - - 0 0
1010 enet 101010 1500 - - - - - 0 0
1111 enet 101111 1500 - - - - - 0 0
3456 enet 103456 1500 - - - - - 0 0

VLAN AREHops STEHops Backup CRF
-----
1003 7 7 off

Remote SPAN VLANs
-----

Primary Secondary Type Ports
-----

DLS1#
DLS1#
DLS1#configure terminal
Enter configuration commands, one per line. End with CNTL/Z.
DLS1(config)#spanning-tree vlan 1,12,434,500,1010,1111,3456 root primary
DLS1(config)#spanning-tree vlan 123,234 root secondary
DLS1(config)#end
DLS1#wr
Building configuration...
Compressed configuration from 2495 bytes to 1358 bytes[OK]
DLS1#
DLS1#
*Nov 16 17:40:24.848: %SYS-5-CONFIG_I: Configured from console by console

```

Figura 70. Configuración Spanning tree root en DLS1

```

DLS1#show spanning-tree

VLAN0001
Spanning tree enabled protocol rstp
Root ID Priority 24577
Address aabb.cc00.0100
This bridge is the root
Hello Time 2 sec Max Age 20 sec Forward Delay 15 sec

Bridge ID Priority 24577 (priority 24576 sys-id-ext 1)
Address aabb.cc00.0100
Hello Time 2 sec Max Age 20 sec Forward Delay 15 sec
Aging Time 300 sec

Interface Role Sts Cost Prio.Nbr Type
-----
Et2/1 Desg FWD 100 128.10 Shr
Et2/2 Desg FWD 100 128.11 Shr

VLAN0012
Spanning tree enabled protocol rstp
Root ID Priority 24588
Address aabb.cc00.0100
This bridge is the root
Hello Time 2 sec Max Age 20 sec Forward Delay 15 sec

Bridge ID Priority 24588 (priority 24576 sys-id-ext 12)
Address aabb.cc00.0100
Hello Time 2 sec Max Age 20 sec Forward Delay 15 sec
Aging Time 300 sec

Interface Role Sts Cost Prio.Nbr Type
-----
Et2/1 Desg FWD 100 128.10 Shr
Et2/2 Desg FWD 100 128.11 Shr

```

Figura 71. Estado Configuración STP DLS1

```

DLS1 x DLS2
VLAN0123
Spanning tree enabled protocol rstp
Root ID Priority 28795
Address aabb.cc00.0100
This bridge is the root
Hello Time 2 sec Max Age 20 sec Forward Delay 15 sec

Bridge ID Priority 28795 (priority 28672 sys-id-ext 123)
Address aabb.cc00.0100
Hello Time 2 sec Max Age 20 sec Forward Delay 15 sec
Aging Time 300 sec

Interface Role Sts Cost Prio.Nbr Type
-----
Et2/1 Desg FWD 100 128.10 Shr
Et2/2 Desg FWD 100 128.11 Shr

VLAN0234
Spanning tree enabled protocol rstp
Root ID Priority 28906
Address aabb.cc00.0100
This bridge is the root
Hello Time 2 sec Max Age 20 sec Forward Delay 15 sec

Bridge ID Priority 28906 (priority 28672 sys-id-ext 234)
Address aabb.cc00.0100
Hello Time 2 sec Max Age 20 sec Forward Delay 15 sec
Aging Time 300 sec

Interface Role Sts Cost Prio.Nbr Type
-----
Et2/1 Desg FWD 100 128.10 Shr
Et2/2 Desg FWD 100 128.11 Shr

VLAN0500
Spanning tree enabled protocol rstp
Root ID Priority 25076
Address aabb.cc00.0100
This bridge is the root
Hello Time 2 sec Max Age 20 sec Forward Delay 15 sec

Bridge ID Priority 25076 (priority 24576 sys-id-ext 500)
Address aabb.cc00.0100
Hello Time 2 sec Max Age 20 sec Forward Delay 15 sec
Aging Time 300 sec

Interface Role Sts Cost Prio.Nbr Type
-----
Et2/1 Desg FWD 100 128.10 Shr
Et2/2 Desg FWD 100 128.11 Shr

VLAN1010
Spanning tree enabled protocol rstp
Root ID Priority 25586
Address aabb.cc00.0100
This bridge is the root
Hello Time 2 sec Max Age 20 sec Forward Delay 15 sec

Bridge ID Priority 25586 (priority 24576 sys-id-ext 1010)
Address aabb.cc00.0100
Hello Time 2 sec Max Age 20 sec Forward Delay 15 sec
Aging Time 300 sec

Interface Role Sts Cost Prio.Nbr Type
-----
Et2/1 Desg FWD 100 128.10 Shr
Et2/2 Desg FWD 100 128.11 Shr

VLAN1111
Spanning tree enabled protocol rstp
Root ID Priority 25687
Address aabb.cc00.0100
This bridge is the root
Hello Time 2 sec Max Age 20 sec Forward Delay 15 sec

Bridge ID Priority 25687 (priority 24576 sys-id-ext 1111)
Address aabb.cc00.0100
Hello Time 2 sec Max Age 20 sec Forward Delay 15 sec
Aging Time 300 sec

Interface Role Sts Cost Prio.Nbr Type
-----

```

Figura 72. Estado Configuración STP DLS1

```

Bridge ID Priority 25076 (priority 24576 sys-id-ext 500)
Address aabb.cc00.0100
Hello Time 2 sec Max Age 20 sec Forward Delay 15 sec
Aging Time 300 sec

Interface Role Sts Cost Prio.Nbr Type
-----
Et2/1 Desg FWD 100 128.10 Shr
Et2/2 Desg FWD 100 128.11 Shr

VLAN1010
Spanning tree enabled protocol rstp
Root ID Priority 25586
Address aabb.cc00.0100
This bridge is the root
Hello Time 2 sec Max Age 20 sec Forward Delay 15 sec

Bridge ID Priority 25586 (priority 24576 sys-id-ext 1010)
Address aabb.cc00.0100
Hello Time 2 sec Max Age 20 sec Forward Delay 15 sec
Aging Time 300 sec

Interface Role Sts Cost Prio.Nbr Type
-----
Et2/1 Desg FWD 100 128.10 Shr
Et2/2 Desg FWD 100 128.11 Shr

VLAN1111
Spanning tree enabled protocol rstp
Root ID Priority 25687
Address aabb.cc00.0100
This bridge is the root
Hello Time 2 sec Max Age 20 sec Forward Delay 15 sec

Bridge ID Priority 25687 (priority 24576 sys-id-ext 1111)
Address aabb.cc00.0100
Hello Time 2 sec Max Age 20 sec Forward Delay 15 sec
Aging Time 300 sec

Interface Role Sts Cost Prio.Nbr Type
-----

```

Figura 73. Estado Configuración STP DLS1

```

DLS1
-----
Interface      Role Sts Cost      Prio.Nbr Type
-----
Et2/1          Desg FWD 100      128.10  Shr
Et2/2          Desg FWD 100      128.11  Shr

VLAN1111
Spanning tree enabled protocol rstp
  Root ID      Priority    25687
                Address    aabb.cc00.0100
                This bridge is the root
                Hello Time  2 sec Max Age 20 sec Forward Delay 15 sec

  Bridge ID    Priority    25687 (priority 24576 sys-id-ext 1111)
                Address    aabb.cc00.0100
                Hello Time  2 sec Max Age 20 sec Forward Delay 15 sec
                Aging Time  300 sec

Interface      Role Sts Cost      Prio.Nbr Type
-----
Et2/1          Desg FWD 100      128.10  Shr
Et2/2          Desg FWD 100      128.11  Shr

VLAN3456
Spanning tree enabled protocol rstp
  Root ID      Priority    28032
                Address    aabb.cc00.0100
                This bridge is the root
                Hello Time  2 sec Max Age 20 sec Forward Delay 15 sec

  Bridge ID    Priority    28032 (priority 24576 sys-id-ext 3456)
                Address    aabb.cc00.0100
                Hello Time  2 sec Max Age 20 sec Forward Delay 15 sec
                Aging Time  300 sec

Interface      Role Sts Cost      Prio.Nbr Type
-----
Et2/1          Desg FWD 100      128.10  Shr
Et2/2          Desg FWD 100      128.11  Shr

DLS1#

```

Figura 74. Estado Configuración STP DLS1

- i. Configurar DLS2 como Spanning tree root para las VLAN 123 y 234 y como una raíz secundaria para las VLAN 12, 434, 500, 1010, 1111 y 3456.

```

DLS2#
DLS2#
DLS2#
DLS2#configure terminal
Enter configuration commands, one per line. End with CNTL/Z.
DLS2(config)#spanning-tree vlan 123,234 root primary
DLS2(config)#spanning-tree vlan 12,434,500,1010,1111,3456 root secondary
DLS2(config)#end
DLS2#wr
Building configuration...
Compressed configuration from 2925 bytes to 1586 bytes[OK]
DLS2#
*Nov 16 18:02:58.460: %SYS-5-CONFIG_I: Configured from console by console
DLS2#
DLS2#
DLS2#

```

Figura 75. Configuración Spanning tree root en DLS2

```

DLS2#show spanning-tree

VLAN0001
Spanning tree enabled protocol rstp
Root ID    Priority    32769
           Address    aabb.cc00.0200
           This bridge is the root
           Hello Time 2 sec Max Age 20 sec Forward Delay 15 sec

           Bridge ID Priority    32769 (priority 32768 sys-id-ext 1)
           Address    aabb.cc00.0200
           Hello Time 2 sec Max Age 20 sec Forward Delay 15 sec
           Aging Time 300 sec

Interface                Role Sts Cost      Prio.Nbr Type
-----
Et2/1                    Desg FWD 100      128.10  Shr
Et2/2                    Desg FWD 100      128.11  Shr

VLAN0012
Spanning tree enabled protocol rstp
Root ID    Priority    28684
           Address    aabb.cc00.0200
           This bridge is the root
           Hello Time 2 sec Max Age 20 sec Forward Delay 15 sec

           Bridge ID Priority    28684 (priority 28672 sys-id-ext 12)
           Address    aabb.cc00.0200
           Hello Time 2 sec Max Age 20 sec Forward Delay 15 sec
           Aging Time 300 sec

Interface                Role Sts Cost      Prio.Nbr Type
-----
Et2/1                    Desg FWD 100      128.10  Shr
Et2/2                    Desg FWD 100      128.11  Shr

```

Figura 76. Estado Configuración STP DLS2

```

DLS2#show spanning-tree

VLAN0123
Spanning tree enabled protocol rstp
Root ID    Priority    24699
           Address    aabb.cc00.0200
           This bridge is the root
           Hello Time 2 sec Max Age 20 sec Forward Delay 15 sec

           Bridge ID Priority    24699 (priority 24576 sys-id-ext 123)
           Address    aabb.cc00.0200
           Hello Time 2 sec Max Age 20 sec Forward Delay 15 sec
           Aging Time 300 sec

Interface                Role Sts Cost      Prio.Nbr Type
-----
Et2/1                    Desg FWD 100      128.10  Shr
Et2/2                    Desg FWD 100      128.11  Shr

VLAN0234
Spanning tree enabled protocol rstp
Root ID    Priority    24810
           Address    aabb.cc00.0200
           This bridge is the root
           Hello Time 2 sec Max Age 20 sec Forward Delay 15 sec

           Bridge ID Priority    24810 (priority 24576 sys-id-ext 234)
           Address    aabb.cc00.0200
           Hello Time 2 sec Max Age 20 sec Forward Delay 15 sec
           Aging Time 300 sec

Interface                Role Sts Cost      Prio.Nbr Type
-----
Et2/1                    Desg FWD 100      128.10  Shr
Et2/2                    Desg FWD 100      128.11  Shr

```

Figura 77. Estado Configuración STP DLS2

```

DLS1
DLS2
VLAN0500
Spanning tree enabled protocol rstp
Root ID Priority 29172
Address aabb.cc00.0200
This bridge is the root
Hello Time 2 sec Max Age 20 sec Forward Delay 15 sec

Bridge ID Priority 29172 (priority 28672 sys-id-ext 500)
Address aabb.cc00.0200
Hello Time 2 sec Max Age 20 sec Forward Delay 15 sec
Aging Time 300 sec

Interface Role Sts Cost Prio.Nbr Type
-----
Et2/1 Desg FwD 100 128.10 Shr
Et2/2 Desg FwD 100 128.11 Shr

VLAN0567
Spanning tree enabled protocol rstp
Root ID Priority 33335
Address aabb.cc00.0200
This bridge is the root
Hello Time 2 sec Max Age 20 sec Forward Delay 15 sec

Bridge ID Priority 33335 (priority 32768 sys-id-ext 567)
Address aabb.cc00.0200
Hello Time 2 sec Max Age 20 sec Forward Delay 15 sec
Aging Time 300 sec

Interface Role Sts Cost Prio.Nbr Type
-----
Et2/1 Desg FwD 100 128.10 Shr
Et2/2 Desg FwD 100 128.11 Shr

solarwinds | Solar-PuTTY free tool © 2019 SolarWinds Worldwide, LLC. All rights reserved.
```

Figura 78. Estado Configuración STP DLS2

```

VLAN1010
Spanning tree enabled protocol rstp
  Root ID    Priority    29682
            Address    aabb.cc00.0200
            This bridge is the root
            Hello Time  2 sec  Max Age 20 sec  Forward Delay 15 sec

  Bridge ID  Priority    29682 (priority 28672 sys-id-ext 1010)
            Address    aabb.cc00.0200
            Hello Time  2 sec  Max Age 20 sec  Forward Delay 15 sec
            Aging Time  300 sec

Interface          Role Sts Cost      Prio.Nbr Type
-----
Et2/1              Desg FWD 100      128.10 Shr
Et2/2              Desg FWD 100      128.11 Shr

VLAN1111
Spanning tree enabled protocol rstp
  Root ID    Priority    29783
            Address    aabb.cc00.0200
            This bridge is the root
            Hello Time  2 sec  Max Age 20 sec  Forward Delay 15 sec

  Bridge ID  Priority    29783 (priority 28672 sys-id-ext 1111)
            Address    aabb.cc00.0200
            Hello Time  2 sec  Max Age 20 sec  Forward Delay 15 sec
            Aging Time  300 sec

Interface          Role Sts Cost      Prio.Nbr Type
-----
Et2/1              Desg FWD 100      128.10 Shr
Et2/2              Desg FWD 100      128.11 Shr

```

Figura 79. Estado Configuración STP DLS2

```

VLAN3456
Spanning tree enabled protocol rstp
  Root ID    Priority    32128
            Address    aabb.cc00.0200
            This bridge is the root
            Hello Time  2 sec  Max Age 20 sec  Forward Delay 15 sec

  Bridge ID  Priority    32128 (priority 28672 sys-id-ext 3456)
            Address    aabb.cc00.0200
            Hello Time  2 sec  Max Age 20 sec  Forward Delay 15 sec
            Aging Time  300 sec

Interface          Role Sts Cost      Prio.Nbr Type
-----
Et2/1              Desg FWD 100      128.10 Shr
Et2/2              Desg FWD 100      128.11 Shr

DLS2#

```

Figura 80. Estado Configuración STP DLS2

- j. Configurar todos los puertos como troncales de tal forma que solamente las VLAN que se han creado se les permitirá circular a través de estos puertos.

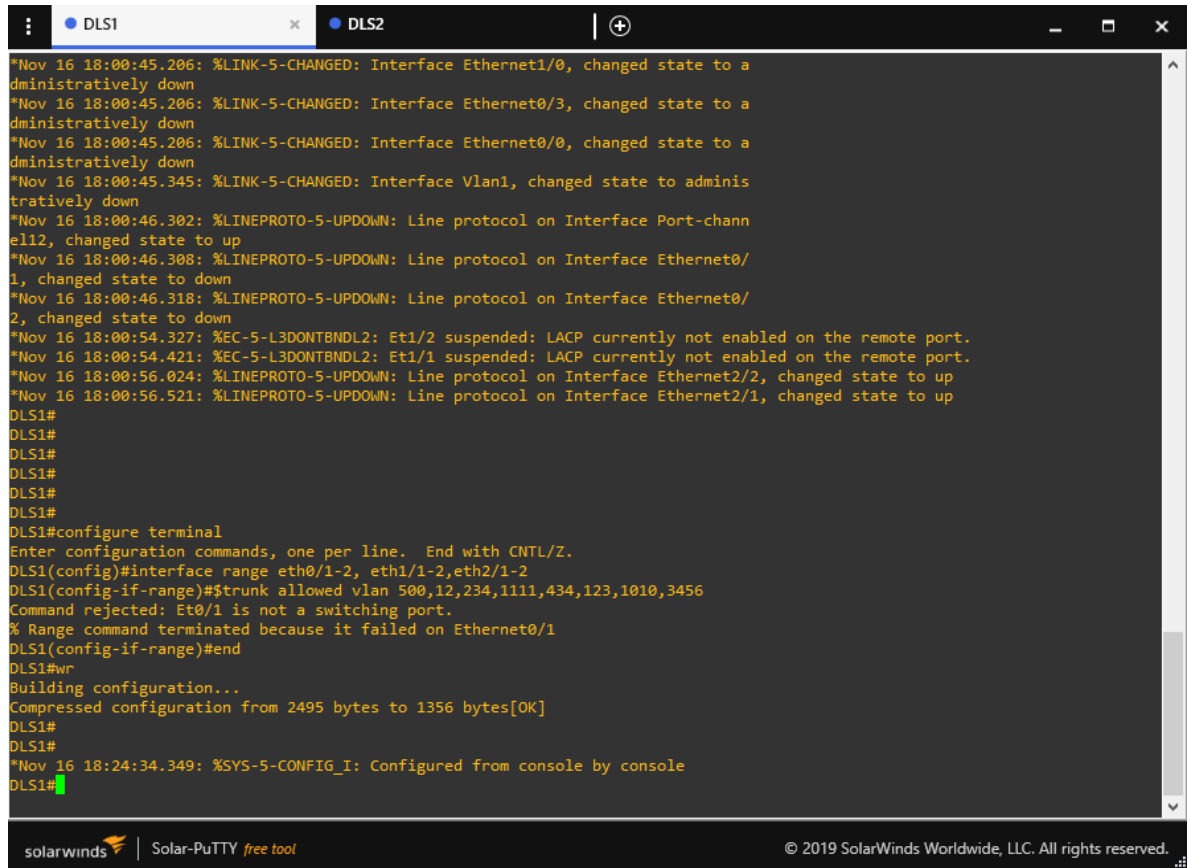

```
*Nov 16 18:00:45.206: %LINK-5-CHANGED: Interface Ethernet1/0, changed state to administratively down
*Nov 16 18:00:45.206: %LINK-5-CHANGED: Interface Ethernet0/3, changed state to administratively down
*Nov 16 18:00:45.206: %LINK-5-CHANGED: Interface Ethernet0/0, changed state to administratively down
*Nov 16 18:00:45.345: %LINK-5-CHANGED: Interface Vlan1, changed state to administratively down
*Nov 16 18:00:46.302: %LINEPROTO-5-UPDOWN: Line protocol on Interface Port-channel12, changed state to up
*Nov 16 18:00:46.308: %LINEPROTO-5-UPDOWN: Line protocol on Interface Ethernet0/1, changed state to down
*Nov 16 18:00:46.318: %LINEPROTO-5-UPDOWN: Line protocol on Interface Ethernet0/2, changed state to down
*Nov 16 18:00:54.327: %EC-5-L3DONTBNDL2: Et1/2 suspended: LACP currently not enabled on the remote port.
*Nov 16 18:00:54.421: %EC-5-L3DONTBNDL2: Et1/1 suspended: LACP currently not enabled on the remote port.
*Nov 16 18:00:56.024: %LINEPROTO-5-UPDOWN: Line protocol on Interface Ethernet2/2, changed state to up
*Nov 16 18:00:56.521: %LINEPROTO-5-UPDOWN: Line protocol on Interface Ethernet2/1, changed state to up
DLS1#
DLS1#
DLS1#
DLS1#
DLS1#
DLS1#
DLS1#configure terminal
Enter configuration commands, one per line. End with CNTL/Z.
DLS1(config)#interface range eth0/1-2, eth1/1-2,eth2/1-2
DLS1(config-if-range)#$trunk allowed vlan 500,12,234,1111,434,123,1010,3456
Command rejected: Et0/1 is not a switching port.
% Range command terminated because it failed on Ethernet0/1
DLS1(config-if-range)#end
DLS1#wr
Building configuration...
Compressed configuration from 2495 bytes to 1356 bytes[OK]
DLS1#
DLS1#
*Nov 16 18:24:34.349: %SYS-5-CONFIG_I: Configured from console by console
DLS1#
```

Figura 81. Configuración VLANs permitidas en DLS1

```

DLS1#
Command rejected: Et0/1 is not a switching port.
% Range command terminated because it failed on Ethernet0/1
DLS1(config-if-range)#end
DLS1#wr
Building configuration...
Compressed configuration from 2495 bytes to 1356 bytes[OK]
DLS1#
DLS1#
*Nov 16 18:24:34.349: %SYS-5-CONFIG_I: Configured from console by console
DLS1#
DLS1#show interfaces trunk

Port      Mode           Encapsulation  Status        Native vlan
Et1/1    on             802.1q         trunking      500
Et1/2    on             802.1q         trunking      500
Et2/1    on             802.1q         trunking      500
Et2/2    on             802.1q         trunking      500

Port      Vlans allowed on trunk
Et1/1    none
Et1/2    none
Et2/1    1-4094
Et2/2    1-4094

Port      Vlans allowed and active in management domain
Et1/1    none
Et1/2    none
Et2/1    1,12,123,234,500,1010,1111,3456
Et2/2    1,12,123,234,500,1010,1111,3456

Port      Vlans in spanning tree forwarding state and not pruned
Et1/1    none
Et1/2    none
Et2/1    1,12,123,234,500,1010,1111,3456

Port      Vlans in spanning tree forwarding state and not pruned
Et2/2    1,12,123,234,500,1010,1111,3456
DLS1#

```

Figura 82. Estado VLANs en DLS1

```

administratively down
*Nov 16 18:34:39.869: %LINK-5-CHANGED: Interface Ethernet0/3, changed state to a
administratively down
*Nov 16 18:34:39.869: %LINK-5-CHANGED: Interface Ethernet0/0, changed state to a
administratively down
*Nov 16 18:34:40.086: %LINK-5-CHANGED: Interface Vlan1, changed state to adminis
tratively down
*Nov 16 18:34:41.024: %LINEPROTO-5-UPDOWN: Line protocol on Interface Port-chann
el12, changed state to up
*Nov 16 18:34:41.034: %LINEPROTO-5-UPDOWN: Line protocol on Interface Ethernet0/
1, changed state to down
*Nov 16 18:34:41.048: %LINEPROTO-5-UPDOWN: Line protocol on Interface Ethernet0/
2, changed state to down
*Nov 16 18:34:49.053: %EC-5-L3DONTBNDL2: Et1/1 suspended: LACP currently not ena
bled on the remote port.
*Nov 16 18:34:49.644: %EC-5-L3DONTBNDL2: Et1/2 suspended: LACP currently not ena
bled on the remote port.
*Nov 16 18:34:50.948: %LINEPROTO-5-UPDOWN: Line protocol on Interface Ethernet2/
2, changed state to up
*Nov 16 18:34:52.052: %LINEPROTO-5-UPDOWN: Line protocol on Interface Ethernet2/
1, changed state to up
DLS2#
DLS2#
DLS2#configure terminal
Enter configuration commands, one per line. End with CNTL/Z.
DLS2(config)#interface range eth0/1-2, eth1/1-2,eth2/1-2
DLS2(config-if-range)#swd vlan 500,12,234,1111,434,123,1010,3456,567
Command rejected: Et0/1 is not a switching port.
% Range command terminated because it failed on Ethernet0/1
DLS2(config-if-range)#end
DLS2#wr
Building configuration...
Compressed configuration from 2925 bytes to 1587 bytes[OK]
DLS2#
DLS2#
*Nov 16 18:35:46.830: %SYS-5-CONFIG_I: Configured from console by console
DLS2#
DLS2#
DLS2#

```

Figura 83. Configuración VLANs permitidas en DLS2

```

DLS2#
% Range command terminated because it failed on Ethernet0/1
DLS2(config-if-range)#end
DLS2#wr
Building configuration...
Compressed configuration from 2925 bytes to 1587 bytes[OK]
DLS2#
*Nov 16 18:35:46.830: %SYS-5-CONFIG_I: Configured from console by console
DLS2#
DLS2#
DLS2#
DLS2#show interfaces trunk

Port      Mode          Encapsulation  Status        Native vlan
Et1/1     on            802.1q         trunking      500
Et1/2     on            802.1q         trunking      500
Et2/1     on            802.1q         trunking      500
Et2/2     on            802.1q         trunking      500

Port      Vlans allowed on trunk
Et1/1     none
Et1/2     none
Et2/1     1-4094
Et2/2     1-4094

Port      Vlans allowed and active in management domain
Et1/1     none
Et1/2     none
Et2/1     1,12,123,234,500,567,1010,1111,3456
Et2/2     1,12,123,234,500,567,1010,1111,3456

Port      Vlans in spanning tree forwarding state and not pruned
Et1/1     none
Et1/2     none
Et2/1     1,12,123,234,500,567,1010,1111,3456

Port      Vlans in spanning tree forwarding state and not pruned
Et2/2     1,12,123,234,500,567,1010,1111,3456
DLS2#

```

Figura 84. Estado VLANs en DLS2

```

DLS1 x DLS2 ALS2 ALS1
*Nov 16 18:34:39.946: %LINK-5-CHANGED: Interface Ethernet3/0, changed state to a
dministratively down
*Nov 16 18:34:39.946: %LINK-5-CHANGED: Interface Ethernet2/3, changed state to a
dministratively down
*Nov 16 18:34:39.946: %LINK-5-CHANGED: Interface Ethernet2/2, changed state to a
dministratively down
*Nov 16 18:34:39.946: %LINK-5-CHANGED: Interface Ethernet2/1, changed state to a
dministratively down
*Nov 16 18:34:39.946: %LINK-5-CHANGED: Interface Ethernet2/0, changed state to a
dministratively down
*Nov 16 18:34:39.946: %LINK-5-CHANGED: Interface Ethernet1/3, changed state to a
dministratively down
*Nov 16 18:34:39.946: %LINK-5-CHANGED: Interface Ethernet1/0, changed state to a
dministratively down
*Nov 16 18:34:39.946: %LINK-5-CHANGED: Interface Ethernet0/3, changed state to a
dministratively down
*Nov 16 18:34:39.946: %LINK-5-CHANGED: Interface Ethernet0/2, changed state to a
dministratively down
*Nov 16 18:34:39.946: %LINK-5-CHANGED: Interface Ethernet0/1, changed state to a
dministratively down
*Nov 16 18:34:39.946: %LINK-5-CHANGED: Interface Ethernet0/0, changed state to a
dministratively down
*Nov 16 18:34:40.086: %LINK-5-CHANGED: Interface Vlan1, changed state to adminis
tratively down
ALS1#
ALS1#
ALS1#configure terminal
Enter configuration commands, one per line. End with CNTL/Z.
ALS1(config)#interface range eth0/1-2, eth1/1-2,eth2/1-2
ALS1(config-if-range)#$trunk allowed vlan 500,12,234,1111,434,123,1010,3456
ALS1(config-if-range)#end
ALS1#wr
Building configuration...
Compressed configuration from 2394 bytes to 1292 bytes[OK]
ALS1#
ALS1#
*Nov 16 18:39:45.487: %SYS-5-CONFIG_I: Configured from console by console
ALS1#
solarwinds Solar-PuTTY free tool © 2019 SolarWinds Worldwide, LLC. All rights reserved.

```

Figura 85. Configuración VLANs permitidas en ALS1

```

DLS1 DLS2 ALS2 ALS1
dministratively down %LINK-5-CHANGED: Interface Ethernet3/0, changed state to a
dministratively down
*Nov 16 18:34:39.945: %LINK-5-CHANGED: Interface Ethernet2/3, changed state to a
dministratively down
*Nov 16 18:34:39.945: %LINK-5-CHANGED: Interface Ethernet2/2, changed state to a
dministratively down
*Nov 16 18:34:39.945: %LINK-5-CHANGED: Interface Ethernet2/1, changed state to a
dministratively down
*Nov 16 18:34:39.945: %LINK-5-CHANGED: Interface Ethernet2/0, changed state to a
dministratively down
*Nov 16 18:34:39.945: %LINK-5-CHANGED: Interface Ethernet1/3, changed state to a
dministratively down
*Nov 16 18:34:39.949: %LINK-5-CHANGED: Interface Ethernet1/0, changed state to a
dministratively down
*Nov 16 18:34:39.949: %LINK-5-CHANGED: Interface Ethernet0/3, changed state to a
dministratively down
*Nov 16 18:34:39.949: %LINK-5-CHANGED: Interface Ethernet0/2, changed state to a
dministratively down
*Nov 16 18:34:39.949: %LINK-5-CHANGED: Interface Ethernet0/1, changed state to a
dministratively down
*Nov 16 18:34:39.949: %LINK-5-CHANGED: Interface Ethernet0/0, changed state to a
dministratively down
*Nov 16 18:34:40.068: %LINK-5-CHANGED: Interface Vlan1, changed state to adminis
tratively down
ALS2#
ALS2#configure terminal
Enter configuration commands, one per line. End with CNTL/Z.
ALS2(config)#interface range eth0/1-2, eth1/1-2,eth2/1-2
ALS2(config-if-range)#$trunk allowed vlan 500,12,234,1111,434,123,1010,3456
ALS2(config-if-range)#end
ALS2#wr
*Nov 16 18:39:38.806: %SYS-5-CONFIG_I: Configured from console by console
ALS2#wr
Building configuration...
Compressed configuration from 2394 bytes to 1289 bytes[OK]
ALS2#
ALS2#
solarwinds Solar-PuTTY free tool © 2019 SolarWinds Worldwide, LLC. All rights reserved.

```

Figura 86. Configuración VLANs permitidas en ALS2

```

ALS1#show interfaces trunk

Port      Mode           Encapsulation  Status        Native vlan
Et1/1    on             802.1q         trunking      500
Et1/2    on             802.1q         trunking      500

Port      Vlans allowed on trunk
Et1/1    12,123,234,434,500,1010,1111,3456
Et1/2    12,123,234,434,500,1010,1111,3456

Port      Vlans allowed and active in management domain
Et1/1    500
Et1/2    500

Port      Vlans in spanning tree forwarding state and not pruned
Et1/1    500
Et1/2    500
ALS1#

```

Figura 87. Estado VLANs en ALS1

```

ALS2#show interfaces trunk

Port      Mode           Encapsulation  Status        Native vlan
Et1/1    on             802.1q         trunking      500
Et1/2    on             802.1q         trunking      500

Port      Vlans allowed on trunk
Et1/1    12,123,234,434,500,1010,1111,3456
Et1/2    12,123,234,434,500,1010,1111,3456

Port      Vlans allowed and active in management domain
Et1/1    500
Et1/2    500

Port      Vlans in spanning tree forwarding state and not pruned
Et1/1    500
Et1/2    500
ALS2#

```

Figura 88. Estado VLANs en ALS2

- k. Configurar las siguientes interfaces como puertos de acceso, asignados a las VLAN de la siguiente manera:

Interfaz	DLS1	DLS2	ALS1	ALS2
Interfaz Fa0/6	3456	12, 1010	123, 1010	234
Interfaz Fa0/15	1111	1111	1111	1111
Interfaces F0 /16-18		567		

Tabla 2. Interfaces

Interfaz	DLS1	DLS2	ALS1	ALS2
Interfaz eth0/0, eth0/3	3456	12, 1010	123, 1010	234
Interfaz eth1/0, eth1/3, eth2/0, eth2/3	1111	1111	1111	1111
Interfaz eth2/0, eth2/3		567		

Tabla 3. Interfaces aplicadas a laboratorio

```
DLS1 x DLS2 ALS1 ALS2
*Nov 16 20:42:27.072: %LINEPROTO-5-UPDOWN: Line protocol on Interface Ethernet2/
2, changed state to up
*Nov 16 20:42:27.266: %LINEPROTO-5-UPDOWN: Line protocol on Interface Ethernet2/
1, changed state to up
DLS1#
DLS1#
DLS1#
DLS1#configure terminal
Enter configuration commands, one per line. End with CNTL/Z.
DLS1(config)#interface range eth0/0, eth0/3
DLS1(config-if-range)#switchport access vlan 3456
DLS1(config-if-range)#no shutdown
DLS1(config-if-range)#interface range eth1/0, eth1/3, eth2/0, eth2/3
DLS1(config-if-range)#switchport access vlan 1111
DLS1(config-if-range)#no shutdown
DLS1(config-if-range)#end
DLS1#wr
Building configuration...
Compressed configuration from 2609 bytes to 1388 bytes[OK]
DLS1#
DLS1#
DLS1#
*Nov 16 20:46:24.551: %SYS-5-CONFIG_I: Configured from console by console
DLS1#
DLS1#
*Nov 16 20:46:26.537: %LINK-3-UPDOWN: Interface Ethernet0/0, changed state to up
*Nov 16 20:46:26.538: %LINK-3-UPDOWN: Interface Ethernet0/3, changed state to up
*Nov 16 20:46:26.552: %LINK-3-UPDOWN: Interface Ethernet1/0, changed state to up
*Nov 16 20:46:26.552: %LINK-3-UPDOWN: Interface Ethernet1/3, changed state to up
*Nov 16 20:46:26.552: %LINK-3-UPDOWN: Interface Ethernet2/0, changed state to up
*Nov 16 20:46:26.553: %LINK-3-UPDOWN: Interface Ethernet2/3, changed state to up
*Nov 16 20:46:27.542: %LINEPROTO-5-UPDOWN: Line protocol on Interface Ethernet0/0, changed state to up
*Nov 16 20:46:27.542: %LINEPROTO-5-UPDOWN: Line protocol on Interface Ethernet0/3, changed state to up
DLS1#
*Nov 16 20:46:27.555: %LINEPROTO-5-UPDOWN: Line protocol on Interface Ethernet1/0, changed state to up
*Nov 16 20:46:27.555: %LINEPROTO-5-UPDOWN: Line protocol on Interface Ethernet1/3, changed state to up
*Nov 16 20:46:27.555: %LINEPROTO-5-UPDOWN: Line protocol on Interface Ethernet2/0, changed state to up
*Nov 16 20:46:27.555: %LINEPROTO-5-UPDOWN: Line protocol on Interface Ethernet2/3, changed state to up
DLS1#
```

Figura 89. Configuración puertos de acceso en DLS1

```
DLS1 DLS2 x ALS1 ALS2
*Nov 16 20:42:27.360: %LINEPROTO-5-UPDOWN: Line protocol on Interface Ethernet2/
1, changed state to up
DLS2#
DLS2#
DLS2#configure terminal
Enter configuration commands, one per line. End with CNTL/Z.
DLS2(config)#interface range eth0/0, eth0/3
DLS2(config-if-range)#switchport access vlan 12
DLS2(config-if-range)#switchport access vlan 1010
DLS2(config-if-range)#no shutdown
DLS2(config-if-range)#interface range eth1/0, eth1/3
DLS2(config-if-range)#switchport access vlan 1111
DLS2(config-if-range)#no shutdown
DLS2(config-if-range)#interface range eth2/0, eth2/3
DLS2(config-if-range)#switchport access vlan 567
DLS2(config-if-range)#no shutdown
DLS2(config-if-range)#end
DLS2#wr
Building configuration...
Compressed configuration from 3037 bytes to 1624 bytes[OK]
DLS2#
DLS2#
DLS2#
*Nov 16 20:48:14.041: %LINK-3-UPDOWN: Interface Ethernet0/0, changed state to up
*Nov 16 20:48:14.042: %LINK-3-UPDOWN: Interface Ethernet0/3, changed state to up
*Nov 16 20:48:14.042: %LINK-3-UPDOWN: Interface Ethernet1/0, changed state to up
*Nov 16 20:48:14.042: %LINK-3-UPDOWN: Interface Ethernet1/3, changed state to up
*Nov 16 20:48:14.047: %LINK-3-UPDOWN: Interface Ethernet2/0, changed state to up
*Nov 16 20:48:14.047: %LINK-3-UPDOWN: Interface Ethernet2/3, changed state to up
*Nov 16 20:48:15.048: %LINEPROTO-5-UPDOWN: Line protocol on Interface Ethernet0/0, changed state to up
*Nov 16 20:48:15.048: %LINEPROTO-5-UPDOWN: Line protocol on Interface Ethernet0/3, changed state to up
*Nov 16 20:48:15.048: %LINEPROTO-5-UPDOWN: Line protocol on Interface Ethernet1/0, changed state to up
*Nov 16 20:48:15.048: %LINEPROTO-5-UPDOWN: Line protocol on Interface Ethernet1/3, changed state to up
*Nov 16 20:48:15.048: %LINEPROTO-5-UPDOWN: Line protocol on Interface Ethernet2/0, changed state to up
*Nov 16 20:48:15.048: %LINEPROTO-5-UPDOWN: Line protocol on Interface Ethernet2/3, changed state to up
DLS2#
```

Figura 90. Configuración puertos de acceso en DLS2

```

DLS1 DLS2 ALS1 ALS2
*Nov 16 20:42:16.208: %LINK-5-CHANGED: Interface Vlan1, changed state to administratively down
ALS1#
ALS1#
ALS1#configure terminal
Enter configuration commands, one per line. End with CNTL/Z.
ALS1(config)#interface range eth0/0-3
ALS1(config-if-range)#switchport access vlan 123
ALS1(config-if-range)#switchport access vlan 1010
ALS1(config-if-range)#no shutdown
ALS1(config-if-range)#interface range eth1/0, eth1/3, eth2/0, eth2/3
ALS1(config-if-range)#switchport access vlan 1111
ALS1(config-if-range)#no shutdown
ALS1(config-if-range)#end
ALS1#wr
Building configuration...
Compressed configuration from 2546 bytes to 1338 bytes[OK]
ALS1#
*Nov 16 20:52:01.364: %SYS-5-CONFIG_I: Configured from console by console
ALS1#
*Nov 16 20:52:01.353: %LINK-3-UPDOWN: Interface Ethernet0/0, changed state to up
*Nov 16 20:52:01.354: %LINK-3-UPDOWN: Interface Ethernet0/1, changed state to up
*Nov 16 20:52:01.354: %LINK-3-UPDOWN: Interface Ethernet0/2, changed state to up
*Nov 16 20:52:01.354: %LINK-3-UPDOWN: Interface Ethernet0/3, changed state to up
*Nov 16 20:52:01.368: %LINK-3-UPDOWN: Interface Ethernet1/0, changed state to up
*Nov 16 20:52:01.369: %LINK-3-UPDOWN: Interface Ethernet1/3, changed state to up
*Nov 16 20:52:01.369: %LINK-3-UPDOWN: Interface Ethernet2/0, changed state to up
*Nov 16 20:52:02.359: %LINEPROTO-5-UPDOWN: Line protocol on Interface Ethernet0/0, changed state to up
*Nov 16 20:52:02.360: %LINEPROTO-5-UPDOWN: Line protocol on Interface Ethernet0/2, changed state to up
*Nov 16 20:52:02.360: %LINEPROTO-5-UPDOWN: Line protocol on Interface Ethernet0/3, changed state to up
*Nov 16 20:52:02.373: %LINEPROTO-5-UPDOWN: Line protocol on Interface Ethernet1/0, changed state to up
*Nov 16 20:52:02.374: %LINEPROTO-5-UPDOWN: Line protocol on Interface Ethernet1/3, changed state to up
*Nov 16 20:52:02.374: %LINEPROTO-5-UPDOWN: Line protocol on Interface Ethernet2/0, changed state to up
*Nov 16 20:52:02.374: %LINEPROTO-5-UPDOWN: Line protocol on Interface Ethernet2/3, changed state to up
ALS1#

```

Figura 91. Configuración puertos de acceso en ALS1

```

DLS1 DLS2 ALS1 ALS2
*Nov 16 20:42:15.919: %LINK-5-CHANGED: Interface Ethernet0/0, changed state to administratively down
*Nov 16 20:42:16.222: %LINK-5-CHANGED: Interface Vlan1, changed state to administratively down
ALS2#
ALS2#configure terminal
Enter configuration commands, one per line. End with CNTL/Z.
ALS2(config)#interface range eth0/0-3
ALS2(config-if-range)#switchport access vlan 234
ALS2(config-if-range)#no shutdown
ALS2(config-if-range)#interface range eth1/0, eth1/3, eth2/0, eth2/3
ALS2(config-if-range)#switchport access vlan 1111
ALS2(config-if-range)#no shutdown
ALS2(config-if-range)#end
ALS2#wr
Building configuration...
Compressed configuration from 2542 bytes to 1327 bytes[OK]
ALS2#
*Nov 16 20:53:10.212: %LINK-3-UPDOWN: Interface Ethernet0/0, changed state to up
*Nov 16 20:53:10.212: %LINK-3-UPDOWN: Interface Ethernet0/1, changed state to up
*Nov 16 20:53:10.213: %LINK-3-UPDOWN: Interface Ethernet0/2, changed state to up
*Nov 16 20:53:10.213: %LINK-3-UPDOWN: Interface Ethernet0/3, changed state to up
*Nov 16 20:53:10.218: %LINK-3-UPDOWN: Interface Ethernet1/0, changed state to up
*Nov 16 20:53:10.218: %LINK-3-UPDOWN: Interface Ethernet1/3, changed state to up
*Nov 16 20:53:10.218: %LINK-3-UPDOWN: Interface Ethernet2/0, changed state to up
*Nov 16 20:53:10.219: %LINK-3-UPDOWN: Interface Ethernet2/3, changed state to up
*Nov 16 20:53:11.219: %LINEPROTO-5-UPDOWN: Line protocol on Interface Ethernet0/0, changed state to up
*Nov 16 20:53:11.219: %LINEPROTO-5-UPDOWN: Line protocol on Interface Ethernet0/1, changed state to up
*Nov 16 20:53:11.219: %LINEPROTO-5-UPDOWN: Line protocol on Interface Ethernet0/2, changed state to up
*Nov 16 20:53:11.219: %LINEPROTO-5-UPDOWN: Line protocol on Interface Ethernet0/3, changed state to up
*Nov 16 20:53:11.219: %LINEPROTO-5-UPDOWN: Line protocol on Interface Ethernet1/0, changed state to up
*Nov 16 20:53:11.219: %LINEPROTO-5-UPDOWN: Line protocol on Interface Ethernet1/3, changed state to up
*Nov 16 20:53:11.219: %LINEPROTO-5-UPDOWN: Line protocol on Interface Ethernet2/0, changed state to up
*Nov 16 20:53:11.219: %LINEPROTO-5-UPDOWN: Line protocol on Interface Ethernet2/3, changed state to up
ALS2#

```

Figura 92. Configuración puertos de acceso en ALS2

Parte 2: conectividad de red de prueba y las opciones configuradas.

Verificar la existencia de las VLAN correctas en todos los switches y la asignación de puertos troncales y de acceso.

Para verificar las VLAN creadas en cada switch emplearemos el comando show vlan.

```
DLS1#show vlan
-----
VLAN Name                Status    Ports
-----
1    default                active    Et3/0, Et3/1, Et3/2, Et3/3
12   ADMON                  active
123  SEGUROS                active
234  CLIENTES               active
434  PROVEEDORES            suspended
500  NATIVA                 active
1002 fddi-default            act/unsup
1003 trcrf-default          act/unsup
1004 fddinet-default        act/unsup
1005 trbrf-default         act/unsup
1010 VENTAS                 active
1111 MULTIMEDIA            active    Et1/0, Et1/3, Et2/0, Et2/3
3456 PERSONAL             active    Et0/0, Et0/3
-----
VLAN Type  SAID      MTU   Parent  RingNo BridgeNo  Stp  BrdgMode Trans1 Trans2
-----
1    enet  100001   1500   -       -       -    -         0      0
12   enet  100012   1500   -       -       -    -         0      0
123  enet  100123   1500   -       -       -    -         0      0
234  enet  100234   1500   -       -       -    -         0      0
-----
DLS1#
```

Figura 93. VLAN creadas en DLS1

Con el comando show interfaces trunk verificaremos las interfaces troncales y las VLAN en sw DLS1.

```
DLS1#show interfaces trunk
-----
Port      Mode          Encapsulation  Status        Native vlan
-----
Et1/1    on            802.1q         trunking      500
Et1/2    on            802.1q         trunking      500
Et2/1    on            802.1q         trunking      500
Et2/2    on            802.1q         trunking      500
-----
Port      Vlans allowed on trunk
-----
Et1/1    none
Et1/2    none
Et2/1    1-4094
Et2/2    1-4094
-----
Port      Vlans allowed and active in management domain
-----
Et1/1    none
Et1/2    none
Et2/1    1,12,123,234,500,1010,1111,3456
Et2/2    1,12,123,234,500,1010,1111,3456
-----
Port      Vlans in spanning tree forwarding state and not pruned
-----
Et1/1    none
Et1/2    none
Et2/1    1,12,123,234,500,1010,1111,3456
-----
Port      Vlans in spanning tree forwarding state and not pruned
-----
Et2/2    1,12,123,234,500,1010,1111,3456
-----
DLS1#
```

Figura 94. Verificación enlaces troncales y VLAN configurados en DLS1

```

DLS2#show vlan

VLAN Name                Status    Ports
-----
1    default                active    Et3/0, Et3/1, Et3/2, Et3/3
12   ADMON                  active
123  SEGUROS                active
234  CLIENTES               active
434  PROVEEDORES            suspended
500  NATIVA                 active
567  PRODUCCION             active    Et2/0, Et2/3
1002 fddi-default            act/unsup
1003 trcrf-default          act/unsup
1004 fddinet-default        act/unsup
1005 trbrf-default        act/unsup
1010 VENTAS                 active    Et0/0, Et0/3
1111 MULTIMEDIA           active    Et1/0, Et1/3
3456 PERSONAL            active

VLAN Type  SAID      MTU   Parent  RingNo  BridgeNo  Stp  BrdgMode  Trans1  Trans2
-----
1    enet  100001   1500  -       -        -       -       -        0       0
12   enet  100012   1500  -       -        -       -       -        0       0
123  enet  100123   1500  -       -        -       -       -        0       0

VLAN Type  SAID      MTU   Parent  RingNo  BridgeNo  Stp  BrdgMode  Trans1  Trans2
-----
234  enet  100234   1500  -       -        -       -       -        0       0
434  enet  100434   1500  -       -        -       -       -        0       0
500  enet  100500   1500  -       -        -       -       -        0       0
567  enet  100567   1500  -       -        -       -       -        0       0
1002 fddi  101002   1500  -       -        -       -       -        0       0
1003 trcrf 101003   4472  1005   3276   -       -       srb      0       0
1004 fdnet 101004   1500  -       -        -       -       ieee     0       0
1005 trbrf 101005   4472  -       -        15      -       ibm      0       0
1010 enet  101010   1500  -       -        -       -       -        0       0
1111 enet  101111   1500  -       -        -       -       -        0       0
3456 enet  103456   1500  -       -        -       -       -        0       0

VLAN AREHops STEHops Backup CRF
-----
1003 7          7          off

```

Figura 95. VLAN creadas en DLS2

```

DLS2#show interfaces trunk

Port      Mode      Encapsulation  Status      Native vlan
Et1/1     on        802.1q         trunking    500
Et1/2     on        802.1q         trunking    500
Et2/1     on        802.1q         trunking    500
Et2/2     on        802.1q         trunking    500

Port      Vlans allowed on trunk
Et1/1     none
Et1/2     none
Et2/1     1-4094
Et2/2     1-4094

Port      Vlans allowed and active in management domain
Et1/1     none
Et1/2     none
Et2/1     1,12,123,234,500,567,1010,1111,3456
Et2/2     1,12,123,234,500,567,1010,1111,3456

Port      Vlans in spanning tree forwarding state and not pruned
Et1/1     none
Et1/2     none
Et2/1     1,12,123,234,500,567,1010,1111,3456

Port      Vlans in spanning tree forwarding state and not pruned
Et2/2     1,12,123,234,500,567,1010,1111,3456
DLS2#

```

Figura 96. Verificación enlaces troncales y VLAN configurados en DLS2

```

DLS1 DLS2 ALS1 ALS2
*Nov 16 20:52:02.360: %LINEPROTO-5-UPDOWN: Line protocol on Interface Ethernet0/2, changed state to up
*Nov 16 20:52:02.360: %LINEPROTO-5-UPDOWN: Line protocol on Interface Ethernet0/3, changed state to up
*Nov 16 20:52:02.373: %LINEPROTO-5-UPDOWN: Line protocol on Interface Ethernet1/0, changed state to up
*Nov 16 20:52:02.374: %LINEPROTO-5-UPDOWN: Line protocol on Interface Ethernet1/3, changed state to up
*Nov 16 20:52:02.374: %LINEPROTO-5-UPDOWN: Line protocol on Interface Ethernet2/0, changed state to up
*Nov 16 20:52:02.374: %LINEPROTO-5-UPDOWN: Line protocol on Interface Ethernet2/3, changed state to up
ALS1#
ALS1#show vlan

VLAN Name                Status    Ports
-----
1    default                active    Et2/1, Et2/2, Et3/0, Et3/1
                                   Et3/2, Et3/3
500  nativa                 active
1002 fddi-default           act/unsup
1003 trcrf-default        act/unsup
1004 fddinet-default       act/unsup
1005 trbrf-default         act/unsup

VLAN Type  SAID      MTU   Parent RingNo BridgeNo  Stp  BrdgMode Trans1 Trans2
-----
1    enet  100001   1500  -     -     -       -   -         0      0
500  enet  100500   1500  -     -     -       -   -         0      0
1002 fddi  101002   1500  -     -     -       -   -         0      0
1003 trcrf 101003   4472  1005  3276  -       -   srb       0      0
1004 fdnet 101004   1500  -     -     -       ieee -         0      0
1005 trbrf 101005   4472  -     -     15      ibm  -         0      0

VLAN AREHops STEHops Backup CRF
-----
VLAN AREHops STEHops Backup CRF
-----
1003 7      7      off

Remote SPAN VLANs
-----

Primary Secondary Type          Ports
-----

```

Figura 97. VLAN creadas en ALS1

```

ALS1#show interfaces trunk

Port      Mode          Encapsulation  Status      Native vlan
Et1/1     on            802.1q         trunking   500
Et1/2     on            802.1q         trunking   500

Port      Vlans allowed on trunk
Et1/1     12,123,234,434,500,1010,1111,3456
Et1/2     12,123,234,434,500,1010,1111,3456

Port      Vlans allowed and active in management domain
Et1/1     500
Et1/2     500

Port      Vlans in spanning tree forwarding state and not pruned
Et1/1     500
Et1/2     500
ALS1#

```

Figura 98. Verificación enlaces troncales y VLAN configurados en ALS1

```

Nov 16 20:53:11.219: %LINEPROTO-5-UPDOWN: Line protocol on Interface Ethernet1/0, changed state to up
Nov 16 20:53:11.219: %LINEPROTO-5-UPDOWN: Line protocol on Interface Ethernet1/3, changed state to up
Nov 16 20:53:11.219: %LINEPROTO-5-UPDOWN: Line protocol on Interface Ethernet2/0, changed state to up
Nov 16 20:53:11.219: %LINEPROTO-5-UPDOWN: Line protocol on Interface Ethernet2/3, changed state to up
ALS2#
ALS2#show vlan

VLAN Name                Status    Ports
-----
1    default                 active    Et2/1, Et2/2, Et3/0, Et3/1
                                   Et3/2, Et3/3
500  nativa                  active
1002 fddi-default            act/unsup
1003 trcrf-default        act/unsup
1004 fddinet-default       act/unsup
1005 trbrf-default        act/unsup

VLAN Type  SAID      MTU   Parent RingNo BridgeNo  Stp  BrdgMode  Trans1  Trans2
-----
1    enet  100001   1500  -     -     -       -   -         0      0
500  enet  100500   1500  -     -     -       -   -         0      0
1002 fddi  101002   1500  -     -     -       -   -         0      0
1003 trcrf 101003   4472  1005  3276  -       -   srb       0      0
1004 fdnet 101004   1500  -     -     -       -   -         0      0
1005 trbrf 101005   4472  -     -     15      -   ibm       0      0

VLAN AREHops STEHops Backup CRF
-----
VLAN AREHops STEHops Backup CRF
-----
1003 7      7      off

Remote SPAN VLANs
-----

Primary Secondary Type          Ports
-----

ALS2#

```

Figura 99. VLAN creadas en ALS2

```

ALS2#show interfaces trunk

Port      Mode      Encapsulation  Status      Native vlan
Et1/1    on        802.1q         trunking    500
Et1/2    on        802.1q         trunking    500

Port      Vlans allowed on trunk
Et1/1    12,123,234,434,500,1010,1111,3456
Et1/2    12,123,234,434,500,1010,1111,3456

Port      Vlans allowed and active in management domain
Et1/1    500
Et1/2    500

Port      Vlans in spanning tree forwarding state and not pruned
Et1/1    500
Et1/2    500
ALS2#

```

Figura 100. Verificación enlaces troncales y VLAN configurados en ALS2

Verificar que el EtherChannel entre DLS1 y ALS1 está configurado correctamente
Con el comando show etherchannel verificaremos el enlace etherchannel entre DLS1 y ALS1.

```
*Nov 16 21:48:52.756: %LINEPROTO-5-UPDOWN: Line protocol on Interface Ethernet2/
2, changed state to up
DLS1#
DLS1#
DLS1#show etherchannel
      Channel-group listing:
      -----

Group: 1
-----
Group state = L2
Ports: 2  Maxports = 4
Port-channels: 1 Max Port-channels = 4
Protocol:  LACP
Minimum Links: 0

Group: 4
-----
Group state = L2
Ports: 2  Maxports = 4
Port-channels: 1 Max Port-channels = 1
Protocol:  PAgP
Minimum Links: 0

Group: 12
-----
Group state = L3
Ports: 2  Maxports = 4
Port-channels: 1 Max Port-channels = 4
Protocol:  LACP
Minimum Links: 0
```

Figura 101. Verificación configuración grupos etherchannel en DLS1

```
ALS1#show etherchannel
      Channel-group listing:
      -----

Group: 1
-----
Group state = L2
Ports: 0  Maxports = 4
Port-channels: 1 Max Port-channels = 1
Protocol:  -
Minimum Links: 0

Group: 3
-----
Group state = L2
Ports: 2  Maxports = 4
Port-channels: 1 Max Port-channels = 1
Protocol:  PAgP
Minimum Links: 0

ALS1#
```

Figura 102. Verificación configuración grupos etherchannel en ALS1

Con el comando `show etherchannel summary` verificaremos el enlace etherchannel entre DLS1 y ALS1.

```
DLS1#show etherchannel summary
Flags: D - down          P - bundled in port-channel
       I - stand-alone  s - suspended
       H - Hot-standby (LACP only)
       R - Layer3       S - Layer2
       U - in use       N - not in use, no aggregation
       f - failed to allocate aggregator

       M - not in use, minimum links not met
       m - not in use, port not aggregated due to minimum links not met
       u - unsuitable for bundling
       w - waiting to be aggregated
       d - default port

       A - formed by Auto LAG

Number of channel-groups in use: 3
Number of aggregators:          3

Group  Port-channel  Protocol    Ports
-----+-----+-----+-----
1      Po1(SD)        LACP        Et1/1(s)  Et1/2(s)
4      Po4(SD)        PAgP        Et2/1(I)  Et2/2(I)
12     Po12(RD)       LACP        Et0/1(D)  Et0/2(D)

DLS1#
```

Figura 103. Verificación configuración grupos etherchannel en DLS1

```
DLS1 ALS1
ALS1#show etherchannel summary
Flags: D - down          P - bundled in port-channel
       I - stand-alone  s - suspended
       H - Hot-standby (LACP only)
       R - Layer3       S - Layer2
       U - in use       N - not in use, no aggregation
       f - failed to allocate aggregator

       M - not in use, minimum links not met
       m - not in use, port not aggregated due to minimum links not met
       u - unsuitable for bundling
       w - waiting to be aggregated
       d - default port

       A - formed by Auto LAG

Number of channel-groups in use: 2
Number of aggregators:          2

Group  Port-channel  Protocol    Ports
-----+-----+-----+-----
1      Po1(SD)        -           Et1/1(I)  Et1/2(I)
3      Po3(SD)        PAgP        Et1/1(I)  Et1/2(I)

ALS1#
```

Figura 104. Verificación configuración grupos etherchannel en ALS1

Verificar la configuración de Spanning tree entre DLS1 o DLS2 para cada VLAN.

Con el comando `show spanning-tree vlan_id` verificaremos la configuración STP en DLS1 y DLS2.

```
DLS1#show spanning-tree vlan 500

VLAN0500
Spanning tree enabled protocol rstp
Root ID    Priority    25076
           Address    aabb.cc00.0100
           This bridge is the root
           Hello Time 2 sec Max Age 20 sec Forward Delay 15 sec

Bridge ID  Priority    25076 (priority 24576 sys-id-ext 500)
           Address    aabb.cc00.0100
           Hello Time 2 sec Max Age 20 sec Forward Delay 15 sec
           Aging Time 300 sec

Interface      Role Sts Cost      Prio.Nbr Type
-----
Et2/1          Desg FWD 100       128.10 Shr
Et2/2          Desg FWD 100       128.11 Shr

DLS1#
```

Figura 105. Verificación configuración STP VLAN 500 en DLS1

```
DLS1#show spanning-tree vlan 12

VLAN0012
Spanning tree enabled protocol rstp
Root ID    Priority    24588
           Address    aabb.cc00.0100
           This bridge is the root
           Hello Time 2 sec Max Age 20 sec Forward Delay 15 sec

Bridge ID  Priority    24588 (priority 24576 sys-id-ext 12)
           Address    aabb.cc00.0100
           Hello Time 2 sec Max Age 20 sec Forward Delay 15 sec
           Aging Time 300 sec

Interface      Role Sts Cost      Prio.Nbr Type
-----
Et2/1          Desg FWD 100       128.10 Shr
Et2/2          Desg FWD 100       128.11 Shr

DLS1#Show spanning-tree vlan 234

VLAN0234
Spanning tree enabled protocol rstp
Root ID    Priority    28906
           Address    aabb.cc00.0100
           This bridge is the root
           Hello Time 2 sec Max Age 20 sec Forward Delay 15 sec

Bridge ID  Priority    28906 (priority 28672 sys-id-ext 234)
           Address    aabb.cc00.0100
           Hello Time 2 sec Max Age 20 sec Forward Delay 15 sec
           Aging Time 300 sec

Interface      Role Sts Cost      Prio.Nbr Type
-----
Et2/1          Desg FWD 100       128.10 Shr
Et2/2          Desg FWD 100       128.11 Shr
```

Figura 106. Verificación configuración STP VLAN 12, 234 en DLS1

```

DLS1#Show spanning-tree vlan 1111

VLAN1111
Spanning tree enabled protocol rstp
Root ID    Priority    25687
           Address    aabb.cc00.0100
           This bridge is the root
           Hello Time 2 sec Max Age 20 sec Forward Delay 15 sec

           Bridge ID Priority    25687 (priority 24576 sys-id-ext 1111)
           Address    aabb.cc00.0100
           Hello Time 2 sec Max Age 20 sec Forward Delay 15 sec
           Aging Time 300 sec

Interface          Role Sts Cost      Prio.Nbr Type
-----
Et1/0              Desg FWD 100      128.5   Shr
Et1/3              Desg FWD 100      128.8   Shr
Et2/0              Desg FWD 100      128.9   Shr
Et2/1              Desg FWD 100      128.10  Shr
Et2/2              Desg FWD 100      128.11  Shr
Et2/3              Desg FWD 100      128.12  Shr

```

Figura 107. Verificación configuración STP VLAN 1111 en DLS1

```

DLS1#Show spanning-tree vlan 434

Spanning tree instance(s) for vlan 434 does not exist.

DLS1#Show spanning-tree vlan 123

VLAN0123
Spanning tree enabled protocol rstp
Root ID    Priority    28795
           Address    aabb.cc00.0100
           This bridge is the root
           Hello Time 2 sec Max Age 20 sec Forward Delay 15 sec

           Bridge ID Priority    28795 (priority 28672 sys-id-ext 123)
           Address    aabb.cc00.0100
           Hello Time 2 sec Max Age 20 sec Forward Delay 15 sec
           Aging Time 300 sec

Interface          Role Sts Cost      Prio.Nbr Type
-----
Et2/1              Desg FWD 100      128.10  Shr
Et2/2              Desg FWD 100      128.11  Shr

DLS1#Show spanning-tree vlan 1010

VLAN1010
Spanning tree enabled protocol rstp
Root ID    Priority    25586
           Address    aabb.cc00.0100
           This bridge is the root
           Hello Time 2 sec Max Age 20 sec Forward Delay 15 sec

           Bridge ID Priority    25586 (priority 24576 sys-id-ext 1010)
           Address    aabb.cc00.0100
           Hello Time 2 sec Max Age 20 sec Forward Delay 15 sec
           Aging Time 300 sec

Interface          Role Sts Cost      Prio.Nbr Type
-----

```

Figura 108. Verificación configuración STP VLAN 123, 1010 en DLS1

```

DLS2#Show spanning-tree vlan 500

VLAN0500
Spanning tree enabled protocol rstp
Root ID    Priority    29172
           Address    aabb.cc00.0200
           This bridge is the root
           Hello Time 2 sec Max Age 20 sec Forward Delay 15 sec

Bridge ID  Priority    29172 (priority 28672 sys-id-ext 500)
           Address    aabb.cc00.0200
           Hello Time 2 sec Max Age 20 sec Forward Delay 15 sec
           Aging Time 300 sec

Interface          Role Sts Cost      Prio.Nbr Type
-----
Et2/1              Desg FWD 100       128.10  Shr
Et2/2              Desg FWD 100       128.11  Shr

DLS2#Show spanning-tree vlan 12

VLAN0012
Spanning tree enabled protocol rstp
Root ID    Priority    28684
           Address    aabb.cc00.0200
           This bridge is the root
           Hello Time 2 sec Max Age 20 sec Forward Delay 15 sec

Bridge ID  Priority    28684 (priority 28672 sys-id-ext 12)
           Address    aabb.cc00.0200
           Hello Time 2 sec Max Age 20 sec Forward Delay 15 sec
           Aging Time 300 sec

Interface          Role Sts Cost      Prio.Nbr Type
-----
Et2/1              Desg FWD 100       128.10  Shr
Et2/2              Desg FWD 100       128.11  Shr

```

Figura 109. Verificación configuración STP VLAN 500, 12 en DLS2

```

DLS2#Show spanning-tree vlan 234

VLAN0234
Spanning tree enabled protocol rstp
Root ID    Priority    24810
           Address    aabb.cc00.0200
           This bridge is the root
           Hello Time 2 sec Max Age 20 sec Forward Delay 15 sec

Bridge ID  Priority    24810 (priority 24576 sys-id-ext 234)
           Address    aabb.cc00.0200
           Hello Time 2 sec Max Age 20 sec Forward Delay 15 sec
           Aging Time 300 sec

Interface          Role Sts Cost      Prio.Nbr Type
-----
Et2/1              Desg FWD 100       128.10  Shr
Et2/2              Desg FWD 100       128.11  Shr

DLS2#Show spanning-tree vlan 1111

VLAN1111
Spanning tree enabled protocol rstp
Root ID    Priority    29783
           Address    aabb.cc00.0200
           This bridge is the root
           Hello Time 2 sec Max Age 20 sec Forward Delay 15 sec

Bridge ID  Priority    29783 (priority 28672 sys-id-ext 1111)
           Address    aabb.cc00.0200
           Hello Time 2 sec Max Age 20 sec Forward Delay 15 sec
           Aging Time 300 sec

Interface          Role Sts Cost      Prio.Nbr Type
-----
Et1/0              Desg FWD 100       128.5   Shr
Et1/3              Desg FWD 100       128.8   Shr
Et2/1              Desg FWD 100       128.10  Shr

```

Figura 110. Verificación configuración STP VLAN 234, 1111 en DLS2

```

DLS2#Show spanning-tree vlan 123

VLAN0123
  Spanning tree enabled protocol rstp
  Root ID    Priority    24699
            Address    aabb.cc00.0200
            This bridge is the root
            Hello Time  2 sec  Max Age 20 sec  Forward Delay 15 sec

  Bridge ID  Priority    24699 (priority 24576 sys-id-ext 123)
            Address    aabb.cc00.0200
            Hello Time  2 sec  Max Age 20 sec  Forward Delay 15 sec
            Aging Time  300 sec

Interface                Role Sts Cost      Prio.Nbr Type
-----
Et2/1                    Desg FWD 100      128.10 Shr
Et2/2                    Desg FWD 100      128.11 Shr

DLS2#Show spanning-tree vlan 1010

VLAN1010
  Spanning tree enabled protocol rstp
  Root ID    Priority    29682
            Address    aabb.cc00.0200
            This bridge is the root
            Hello Time  2 sec  Max Age 20 sec  Forward Delay 15 sec

  Bridge ID  Priority    29682 (priority 28672 sys-id-ext 1010)
            Address    aabb.cc00.0200
            Hello Time  2 sec  Max Age 20 sec  Forward Delay 15 sec
            Aging Time  300 sec

Interface                Role Sts Cost      Prio.Nbr Type
-----
Et0/0                    Desg FWD 100      128.1  Shr
Et0/3                    Desg FWD 100      128.4  Shr
Et2/1                    Desg FWD 100      128.10 Shr

```

Figura 111. Verificación configuración STP VLAN 123, 1010 en DLS2

```

DLS2#Show spanning-tree vlan 3456

VLAN3456
  Spanning tree enabled protocol rstp
  Root ID    Priority    32128
            Address    aabb.cc00.0200
            This bridge is the root
            Hello Time  2 sec  Max Age 20 sec  Forward Delay 15 sec

  Bridge ID  Priority    32128 (priority 28672 sys-id-ext 3456)
            Address    aabb.cc00.0200
            Hello Time  2 sec  Max Age 20 sec  Forward Delay 15 sec
            Aging Time  300 sec

Interface                Role Sts Cost      Prio.Nbr Type
-----
Et2/1                    Desg FWD 100      128.10 Shr
Et2/2                    Desg FWD 100      128.11 Shr

DLS2#

```

Figura 112. Verificación configuración STP VLAN 3456 en DLS2

CONCLUSIONES

Realizando la verificación de los detalles expuestos para el escenario, se procede a configurar los enrutadores paso a paso, se agregan las tarjetas seriales externas sin problemas.

Durante el proceso de configuración, se tuvo en cuenta anexar el enrutador R3 a EIGRP para tener los dos protocolos en un equipo así más fácil sería la distribución entre procesos.

Se cometió un error en la distribución de las IP loopback en los R1 y R5, se colocaron IPs consecutivas las cuales presentaron problemas de overlap, se decide cambiarlas cada loopback con una IP en rango distinto y se reparó el inconveniente.

Se tuvo inconvenientes en distribución de las redes pertenecientes a las loopback del R1 ya que inicialmente se configuro en el proceso de OSPF una wildcard equivocada se cambia de 0.0.3.255 a 0.0.255.255 con eso se ajusta y se propaga satisfactoriamente esas redes.

Con el show ip route en los R1 y R5 se puede observar que se tiene conectividad de extremo a extremo con eso se cumple con el objetivo del escenario de enrutamiento.

En el segundo escenario se presentaron problemas con el simulador de Cisco Packet Tracer, ya que no es compatible con algunos códigos necesarios para la correcta configuración de los dispositivos, por tanto, se decidió realizar la prueba con la plataforma GNS3 lo cual, también se presentaron problemas con respecto a las imágenes de conmutadores o switch necesarios.

Se realizó satisfactoriamente los escenarios expuestos como prueba de habilidades en etapa final del diplomado de profundización Cisco CCNP, se dio uso a las diferentes herramientas y conocimientos durante el transcurso del curso, lo que permitió cumplir con el objetivo plasmado en este documento final.

BIBLIOGRAFÍA

Froom, R., Frahim, E. (2015). CISCO Press (Ed). Network Design Fundamentals. Implementing Cisco IP Switched Networks (SWITCH) Foundation Learning Guide CCNP SWITCH 300-115. Recuperado de <https://1drv.ms/b/s!AmIJYei-NT1InWR0hoMxgBNv1CJ>

Teare, D., Vachon B., Graziani, R. (2015). CISCO Press (Ed). Basic Network and Routing Concepts. Implementing Cisco IP Routing (ROUTE) Foundation Learning Guide CCNP ROUTE 300-101. Recuperado de <https://1drv.ms/b/s!AmIJYei-NT1InMfy2rhPZHwEoWx>

Teare, D., Vachon B., Graziani, R. (2015). CISCO Press (Ed). Routers and Routing Protocol Hardening. Implementing Cisco IP Routing (ROUTE) Foundation Learning Guide CCNP ROUTE 300-101. Recuperado de <https://1drv.ms/b/s!AmIJYei-NT1InMfy2rhPZHwEoWx>

ANEXOS

Script Routers Escenario 1

Router 1

```
hostname R1
```

```
interface serial 0/2/0
```

```
ip address 10.113.12.1 255.255.255.0
```

```
clock rate 56000
```

```
no shutdown
```

```
interface loopback 1
```

```
ip address 10.1.1.1 255.255.252.0
```

```
no shutdown
```

```
interface loopback 2
```

```
ip address 10.1.1.2 255.255.252.0
```

```
no shutdown
```

```
interface loopback 3
```

```
ip address 10.1.1.3 255.255.252.0
```

```
no shutdown
```

```
interface loopback 4
```

```
ip address 10.1.1.4 255.255.252.0
```

```
no shutdown
```

```
router ospf 1
router-id 1.1.1.1
network 10.113.12.0 0.0.0.255 area 5
network 10.1.0.0 0.0.255.255 area 5
```

Router 2

```
hostname R2
interface serial 0/2/0
ip address 10.113.12.2 255.255.255.0
no shutdown
```

```
interface serial 0/2/1
ip address 10.113.13.1 255.255.255.0
no shutdown
```

```
router ospf 1
router-id 2.2.2.2
network 10.113.12.0 0.0.0.255 area 5
network 10.113.13.0 0.0.0.255 area 5
```

Router 3

```
hostname R3
interface serial 0/2/0
ip address 10.113.13.2 255.255.255.0
clock rate 56000
no shutdown
```

```
interface serial 0/2/1
ip address 172.19.34.1 255.255.255.0
no shutdown
router ospf 1
router-id 3.3.3.3
network 10.113.13.0 0.0.0.255 area 5
redistribute eigrp 15 metric 50000 subnets
```

```
router eigrp 15
network 172.19.45.0
redistribute ospf 1 metric 1544 20000 255 1 1500
```

Router 4

```
hostname R4
interface serial 0/2/0
ip address 172.19.34.2 255.255.255.0
clock rate 56000
no shutdown
```

```
interface serial 0/2/1
ip address 172.19.45.1 255.255.255.0
no shutdown
```

```
router eigrp 15
network 172.19.45.0
```

Router 5

```
hostname R5
interface serial 0/2/0
ip address 172.19.45.2 255.255.255.0
clock rate 56000
no shutdown
```

```
router eigrp 15
network 172.19.45.0
```

```
interface loopback 1
ip address 172.5.1.1 255.255.252.0
no shutdown
```

```
interface loopback 2
ip address 172.5.1.2 255.255.252.0
no shutdown
```

```
interface loopback 3
ip address 172.5.1.3 255.255.252.0
no shutdown
```

```
interface loopback 4
ip address 172.5.1.4 255.255.252.0
no shutdown
router eigrp 15
network 172.5.0.0
```

Script Routers Escenario 2

Switch DLS1

```
configure terminal
interface range eth0/0-3,eth1/0-3,eth2/0-3,eth3/0-3
shutdown
exit
wr
```

```
configure terminal
interface port-channel 12
no switchport
ip address 10.12.12.1 255.255.255.252
exit
interface range eth0/1-2
no switchport
channel-group 12 mode active
end
wr
```

```
configure terminal
interface range eth1/1,eth1/2
switchport trunk encapsulation dot1q
switchport mode trunk
channel-group 1 mode active
no shutdown
end
```

```
configure terminal
interface range eth2/1-2
switchport trunk encapsulation dot1q
switchport mode trunk
channel-group 4 mode desirable
no shutdown
end
wr
```

```
configure terminal
vlan 500
name nativa
exit
interface range eth1/1-2,eth2/1-2
switchport trunk native vlan 500
exit
interface port-channel 1
switchport trunk native vlan 500
exit
interface port-channel 4
switchport trunk native vlan 500
end
wr
```

```
vtp primary vlan
configure terminal
vtp domain CISCO
vtp version 3
```

```
vtp mode server
vtp pass ccnp321
```

```
vtp primary vlan
configure terminal
vlan 500
name NATIVA
vlan 12
name ADMON
vlan 234
name CLIENTES
vlan 1111
name MULTIMEDIA
vlan 434
name PROVEEDORES
vlan 123
name SEGUROS
vlan 1010
name VENTAS
vlan 3456
name PERSONAL
end
wr
```

```
configure terminal
vlan 434
state suspend
```

```
configure terminal
spanning-tree vlan 1,12,434,500,1010,1111,3456 root primary
spanning-tree vlan 123,234 root secondary
end
wr
```

```
configure terminal
interface range eth0/1-2, eth1/1-2,eth2/1-2
switchport trunk allowed vlan 500,12,234,1111,434,123,1010,3456
end
wr
```

```
switchport trunk encap dot1q
switchport trunk native vlan 500
switchport mode trunk
end
```

```
configure terminal
interface range eth0/0, eth0/3
switchport access vlan 3456
no shutdown
interface range eth1/0, eth1/3, eth2/0, eth2/3
switchport access vlan 1111
no shutdown
end
wr
```

Switch DLS2

```
configure terminal
interface range eth0/0-3,eth1/0-3,eth2/0-3,eth3/0-3
shutdown
end
wr
```

```
configure terminal
interface port-channel 12
no switchport
ip address 10.12.12.2 255.255.255.252
exit
interface range eth0/1-2
no switchport
channel-group 12 mode active
end
wr
```

```
configure terminal
interface range eth1/1,eth1/2
switchport trunk encapsulation dot1q
switchport mode trunk
channel-group 2 mode active
no shutdown
end
wr
```

```
configure terminal
interface range eth2/1-2
switchport trunk encapsulation dot1q
switchport mode trunk
channel-group 3 mode desirable
no shutdown
end
wr
```

```
configure terminal
vlan 500
name nativa
exit
interface range eth1/1-2,eth2/1-2
switchport trunk native vlan 500
exit
interface port-channel 2
switchport trunk native vlan 500
exit
interface port-channel 3
switchport trunk native vlan 500
end
wr
```

```
configure terminal
vtp domain CISCO
vtp version 2
vtp mode trans
```

```
vlan 500
name NATIVA
vlan 12
name ADMON
vlan 234
name CLIENTES
vlan 1111
name MULTIMEDIA
vlan 434
name PROVEEDORES
vlan 123
name SEGUROS
vlan 1010
name VENTAS
vlan 3456
name PERSONAL
end
```

```
configure terminal
vlan 434
state suspend
end
```

```
configure terminal
vlan 567
name PRODUCCION
private-vlan isolated
end
```

```
configure terminal
interface port-channel 2
switchport trunk allowed vlan except 567
interface port-channel 3
switchport trunk allowed vlan except 567
end
```

```
configure terminal
spanning-tree vlan 123,234 root primary
spanning-tree vlan 12,434,500,1010,1111,3456 root secondary
end
```

```
configure terminal
interface range eth0/1-2, eth1/1-2,eth2/1-2
switchport trunk allowed vlan 500,12,234,1111,434,123,1010,3456,567
end
```

```
configure terminal
interface range eth0/0, eth0/3
switchport access vlan 12
switchport access vlan 1010
no shutdown
interface range eth1/0, eth1/3
switchport access vlan 1111
no shutdown
interface range eth2/0, eth2/3
switchport access vlan 567
no shutdown
```

Switch ALS1

```
configure terminal
interface range eth0/0-3,eth1/0-3,eth2/0-3,eth3/0-3
shutdown
end
```

```
configure terminal
interface range eth1/1,eth1/2
switchport trunk encapsulation dot1q
switchport mode trunk
channel-group 1 mode active
no shutdown
end
```

```
configure terminal
interface range e1/1-2
switchport trunk encapsulation dot1q
switchport mode trunk
channel-group 3 mode desirable
no shutdown
end
```

```
configure terminal
vlan 500
name nativa
exit
interface range Eth1/1-2,Eth2/1-2
```

```
switchport trunk native vlan 500
```

```
exit
```

```
interface port-channel 1
```

```
switchport trunk native vlan 500
```

```
exit
```

```
interface port-channel 3
```

```
switchport trunk native vlan 500
```

```
end
```

```
configure terminal
```

```
vtp domain CISCO
```

```
vtp pass ccnp321
```

```
vtp version 3
```

```
vtp mode client
```

```
end
```

```
configure terminal
```

```
interface range eth0/1-2, eth1/1-2,eth2/1-2
```

```
switchport trunk allowed vlan 500,12,234,1111,434,123,1010,3456
```

```
end
```

```
configure terminal
```

```
interface range eth0/0-3
```

```
switchport access vlan 123
```

```
switchport access vlan 1010
```

```
no shutdown
```

```
interface range eth1/0, eth1/3, eth2/0, eth2/3
```

```
switchport access vlan 1111
```

```
no shutdown
```

Switch ALS2

```
configure terminal
interface range eth0/0-3,eth1/0-3,eth2/0-3,eth3/0-3
shutdown
end
```

```
configure terminal
interface range eth1/1,eth1/2
switchport trunk encapsulation dot1q
switchport mode trunk
channel-group 2 mode active
no shutdown
end
```

```
configure terminal
interface range e1/1-2
switchport trunk encapsulation dot1q
switchport mode trunk
channel-group 4 mode desirable
no shutdown
end
```

```
configure terminal
vlan 500
name nativa
exit
interface range Eth1/1-2,Eth2/1-2
```

```
switchport trunk native vlan 500
exit
interface port-channel 2
switchport trunk native vlan 500
exit
interface port-channel 4
switchport trunk native vlan 500
end
```

```
configure terminal
vtp domain CISCO
vtp pass ccnp321
vtp version 3
vtp mode client
end
```

```
configure terminal
interface range eth0/1-2, eth1/1-2,eth2/1-2
switchport trunk allowed vlan 500,12,234,1111,434,123,1010,3456
end
```

```
configure terminal
interface range eth0/0-3
switchport access vlan 234
no shutdown
interface range eth1/0, eth1/3, eth2/0, eth2/3
switchport access vlan 1111
no shutdown
```